

HD-9 Four-Post Lift

Installation and Operation Manual

Manual P/N 5900033 — Manual Revision H2 — August 2022

Models:

- HD-9SW
- HD-9SW-E
- HD-9SWX



Designed and engineered by BendPak Inc. in Southern California, USA. Made in China.

 **DANGER**

IMPORTANT Safety Instructions, save these instructions! Read the *entire contents* of this manual *before* using this product. Failure to follow the instructions and safety precautions in this manual can result in serious injury or death. Make sure all other operators also read this manual. Keep the manual near the product for future reference. *By proceeding with installation and operation, you agree that you fully understand the contents of this manual and assume full responsibility for product use.*

Manual. HD-9SW Series Four Post Lifts, *Installation and Operation Manual*, Manual P/N 5900033, Manual Revision H2, Released August 2022.

Copyright. Copyright © 2022 by BendPak Inc. All rights reserved. You may make copies of this document if you agree that: you will give full attribution to BendPak Inc., you will not make changes to the content, you do not gain any rights to this content, and you will not use the copies for commercial purposes.

Trademarks. BendPak and the BendPak logo are registered trademarks of BendPak Inc. All other company, product, and service names are used for identification only. All trademarks and registered trademarks mentioned in this manual are the property of their respective owners.

Limitations. Every effort has been made to make sure complete and accurate instructions are included in this manual. However, product updates, revisions, and/or changes may have occurred since this manual was published. BendPak reserves the right to change any information in this manual without incurring any obligation for equipment previously or subsequently sold. BendPak is not responsible for typographical errors in this manual. You can always find the latest version of the **manual for your product on the BendPak website**.

Warranty. The BendPak warranty is more than a commitment to you: it is also a commitment to the value of your new product. Contact your nearest BendPak dealer or visit www.bendpak.com/support/warranty for full warranty details. Go to bendpak.com/support/register-your-product/ and fill out the online form to register your product (be sure to click **Submit**).

Safety. Your product was designed and manufactured with safety in mind. However, your safety also depends on proper training and thoughtful operation. Do not install, operate, maintain, or repair the unit without reading and understanding this manual and the labels on the unit; **do not use your Lift unless you can do so safely!**

Owner Responsibility. In order to ensure operator safety and maintain your product properly, it is the responsibility of the product owner to read and follow these instructions:

- Follow all setup, operation, and maintenance instructions.
- Make sure product setup and use conforms to all applicable local, state, and federal codes, rules, and regulations, such as state and federal OSHA regulations and electrical codes.
- Read and follow all safety instructions. Keep them readily available for operators.
- Make sure all operators are properly trained, know how to safely operate the unit, and are properly supervised.
- Do not operate the product until you are certain all parts are in place and operating correctly.
- Carefully inspect the product on a regular basis and perform all maintenance as specified.
- Service and maintain the unit only with approved replacement parts.
- Keep all instructions permanently with the product and make sure all labels are clean and visible.
- BendPak makes no promises, guarantees or assurances that our products meet any state, county, federal or international mandated permit, license, code, standard, certification, or any other mandate other than what is listed or shown on BendPak website(s), or any BendPak or Ranger online or published catalog. Not all BendPak lift models meet the standards as prescribed by ANSI/ALI ALCTV-(current edition) or ANSI/UL 201. Consult www.autolift.org for a complete list of lift models that meet ANSI/ALI ALCTV-(current edition) or ANSI/UL 201 or contact BendPak via contact@bendpak.com. Buyer assumes full responsibility for any state, county, federal or international mandated permit, license, code, standard, certification, or any other mandate required related to the installation and/or operation of any BendPak or Ranger product. BENDPAK will not be responsible for any charges, fines, liens, or other levies imposed on the Buyer related to any special or regional structural, seismic or any other building code and/or codes such as the Uniform Building Code (UBC), International Building Code (IBC), or any other state, county, federal or international mandated permit, license, code, standard, certification, or other mandate, law, rule, regulation or directive by any other agency, government, administrations, or corporations whether state, county, federal, or international mandated.
- **Only use the Lift if it can be used safely!**

Unit Information. Enter the Model Number, Serial Number, and the Date of Manufacture from the label on your unit. This information is required for part or warranty issues.

Model: _____

Serial: _____

Date of Manufacture: _____

BP BendPak Santa Paula, CA USA www.bendpak.com	
MODEL NUMBER	
DESCRIPTION	
LIFT CAPACITY	DATE OF MFG.
ROLLING JACK MAX CAP.	MAX PSI / BAR
VOLTAGE <input type="checkbox"/> 110-240V, 50-60 Hz, 1 Ph <input type="checkbox"/> 208-240V, 50-60 Hz, 1 Ph <input type="checkbox"/> 380-415V, 50-60 Hz, 3 Ph <input type="checkbox"/> 208-440V, 50-60 Hz, 3 Ph	SERIAL NUMBER
UPC	
⚠ DANGER! Disconnect Power Before Servicing CE EAC WARRANTY VOID IF DATA PLATE IS REMOVED PN 5905953	

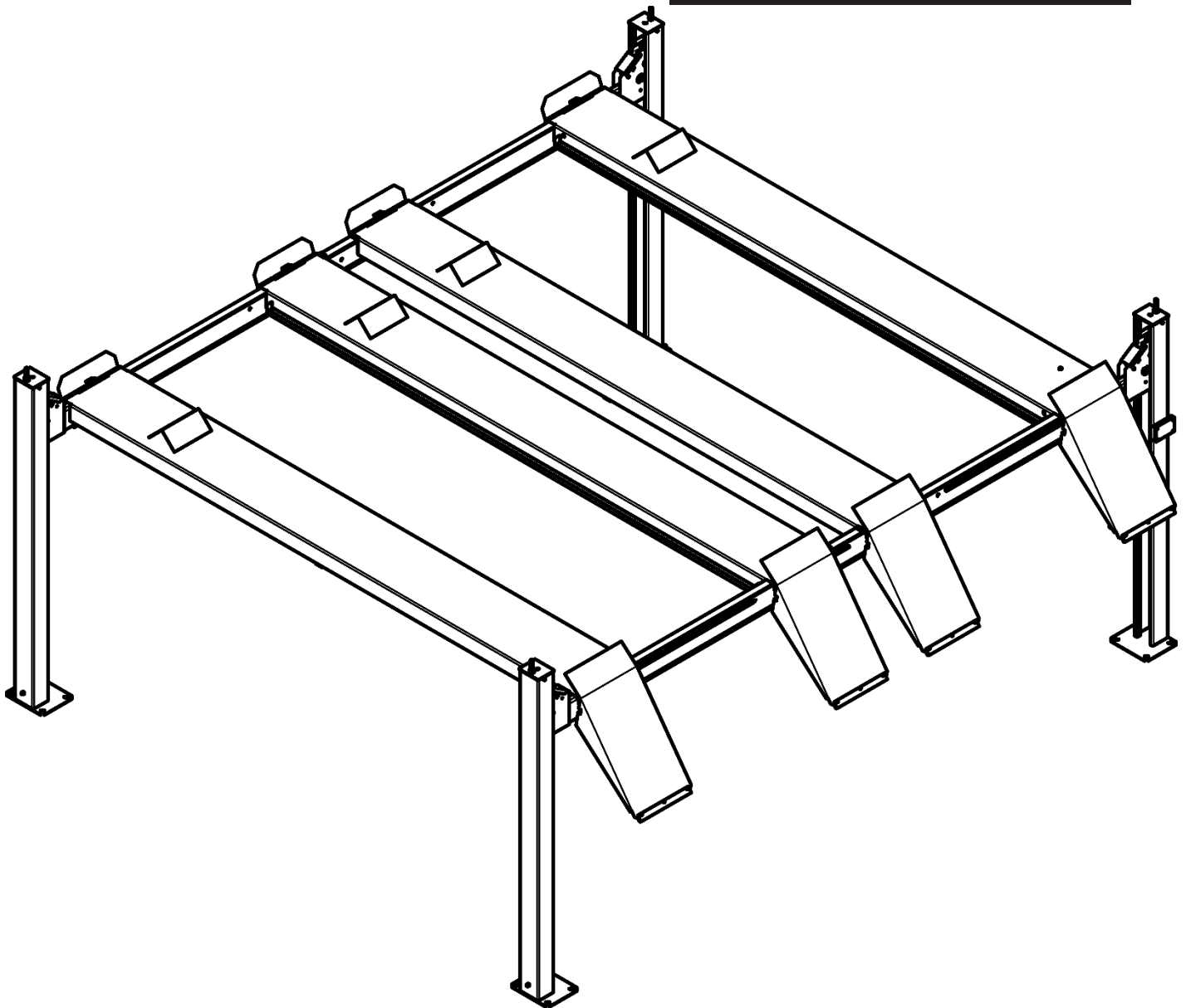

Table of Contents

Shipping Information	5	Operation	61
Safety Considerations	5	Maintenance	64
Components	8	Troubleshooting	66
Additional Products	9	Wiring Diagrams	67
FAQs	10	Labels	68
Specifications	11	Parts Drawings	71
Installation Checklist	13	Maintenance Logs	84
Installation	14		

Introduction

This manual describes the following BendPak Four Post Lifts:

- **HD-9SW.** Wide Four Post Lift with an overall width of 202 inches (17 feet), supporting Vehicles up to 9,000 lbs. (4,082 kg).
- **HD-9SW-E.** Extra-wide Four-Post Lift with an overall width of 248 inches (21 feet), supporting Vehicles up to 9,000 lbs. (4,082 kg).
- **HD-9SWX.** Has the same overall width as the HD-9SW, but with a *higher rise* and *extended Runways*, supporting Vehicles up to 9,000 lbs. (4,082 kg).

This manual is mandatory reading for *all users* of the HD-9SW Series, including anyone who installs, uses, maintains, repairs, or wants to know more about them.

⚠ DANGER Use care when installing, operating, maintaining, or repairing this equipment; failure to do so could result in property damage, product damage, injury, or (in very rare cases) death. Make sure only authorized personnel operate this equipment. All repairs must be performed by an authorized technician. Do not make modifications to the unit; this voids the warranty and increases the chances of injury or property damage. Make sure to read and follow the instructions in this manual and on the labels on the unit.

Keep this manual on or near the equipment so that anyone who uses or services it can read it.

If you are having issues, refer to the **Troubleshooting** section of this manual for assistance.

Technical support and service is available from your dealer, on the Web at [bendpak.com/support](https://www.bendpak.com/support), by email at support@bendpak.com, or by phone at **(800) 253-2363**, extension 196. You may also contact BendPak for parts replacement information at **(800) 253-2363**, extension 191; please have the model and serial number of your unit available.

Shipping Information

Your equipment was carefully checked before shipping. Nevertheless, you should thoroughly inspect the shipment **before** you sign to acknowledge that you received it.

When you sign a bill of lading, it tells the carrier that the items on the invoice were received in good condition. **To protect yourself, do not sign until after you have inspected the shipment.** If any of the items listed on the bill of lading are missing or are damaged, do not accept the shipment until the carrier makes a notation on the bill of lading that lists the missing and/or damaged goods.

If you discover missing or damaged goods **after** you receive the shipment and have signed the bill of lading, notify the carrier at once and request the carrier to make an inspection. If the carrier will not make an inspection, prepare a signed statement to the effect that you have notified the carrier (on a specific date) and that the carrier has failed to comply with your request.

It is difficult to collect for loss or damage after you have given the carrier a signed bill of lading. If this happens to you, file a claim with the carrier promptly. Support your claim with copies of the bill of lading, freight bill, invoice, and photographs, if available. **Our willingness to assist in helping you process your claim does not make us responsible for collection of claims or replacement of lost or damaged materials.**

Safety Considerations

Read this entire manual carefully before using your new product. Do not install or operate the product until you are familiar with all operating instructions and warnings. Refer to ANSI/ALI ALIS Standard *Safety Requirements for Installation and Service of Automotive Lifts* for more information about safely installing your Lift.

 **WARNING California Proposition 65.** This product can expose you to chemicals including styrene and vinyl chloride which are on the list of over 900 chemicals identified by the State of California to cause cancer, birth defects or reproductive harm. **ALWAYS** use this product in accordance with BendPak BendPak's instructions. For more information go to www.P65Warnings.ca.gov.

IMPORTANT SAFETY INSTRUCTIONS!

SAVE THESE INSTRUCTIONS!

1. Read all instructions.
2. Care must be taken as burns can occur from touching hot parts.
3. Do not operate equipment with a damaged cord or if the equipment has been dropped or damaged – until it has been examined by a qualified service person.
4. Do not let a cord hang over the edge of a table, bench, or counter or come in contact with hot manifolds or moving fan blades.
5. If an extension cord is necessary, a cord with a current rating equal to or more than that of the equipment should be used. Cords with a current rating less than the equipment may overheat. Care should be taken to arrange the cord so that it will not be tripped over or pulled.

-
6. Always unplug the equipment from the electrical outlet when not in use. Never use the cord to pull the plug from the outlet. Grasp the plug and pull to disconnect.
 7. Let the equipment cool completely before putting away. Loop cord loosely around equipment when storing.
 8. To reduce the risk of fire, do not operate in the vicinity of open containers of flammable liquids (gasoline).
 9. Adequate ventilation should be provided when working on operating-internal combustion engines.
 10. Keep hair, loose clothing, fingers, and all parts of body away from moving parts.
 11. To reduce the risk of electric shock, do not use on wet surfaces or expose to rain.
 12. Use only as described in this manual. Use only BendPak recommended attachments.
 13. ALWAYS WEAR SAFETY GLASSES. Everyday eyeglasses only have impact resistant lenses, they are not safety glasses.
 14. To reduce the risk of injury, close supervision is necessary when this product will be used around children.
 15. To reduce the risk of injury, **never** attempt to lift more than the rated capacity. Refer to loading instructions.
 16. The Lift uses electrical energy; if your organization has Lockout/Tagout policies, make sure to implement them after connecting the Lift to a power source.
 17. Refer to markings for proper load on electrical receptacles.
 18. Only operate your Lift between temperatures of +41°F to +104°F (+5°C to +40°C).
 19. The Lift should **only** be operated by authorized personnel. Keep children and untrained personnel away from the Lift.
 20. Do not make any modifications to the Lift; this voids the warranty and increases the chances of injury or property damage.
 21. Do not use the Lift while tired or under the influence of drugs, alcohol, or medication.
 22. Consider the work environment. Keep the work area clean. Cluttered work areas invite injuries. Keep areas well lit.
 23. **Always** make sure the Lift is secured on Safety Locks before attempting to work on or near a Vehicle.
 24. Make a thorough inspection of the product at least once a year. Replace any damaged or severely worn parts, decals, or warning labels. Replace worn or damaged parts with BendPak or BendPak approved parts and assemblies only.
 25. BendPak recommends referring to the ANSI/ALI ALIS Standard *Safety Requirements for Installation and Service* for more information about safely installing, using, and servicing your Lift.
 26. **HD-9SW** Series Lifts are 4-Post Vehicle Lifts. **Use them only for their intended purpose.**
 27. You **must** wear OSHA-approved (publication 3151) personal protective equipment at all times when installing, using, maintaining, or repairing the Lift. Leather gloves, steel-toed work boots, eye protection, back belts, and hearing protection are **mandatory**.
 28. Keep loads balanced on the Lift Arms. Clear the area immediately if a Vehicle is in danger of falling off the Lift. Do not make any modifications to the Lift.

29. Modifications void the warranty and increases the chances of injury or property damage. **Do not modify any safety-related features in any way.**

Make sure all operators read and understand this Installation and Operation Manual. **Keep the manual near the Lift at all times.**

30. While handling a Hydraulic Cylinder or a Hydraulic Hose, **always** wear gloves. In rare cases, a needle-like stream of hydraulic fluid (even at low pressure) can penetrate fingers, hands, or arms; such a puncture can feel like a bite, electric shock, or a prick. While it may seem like a minor issue, any amount of Hydraulic Fluid injected into the human body is a serious issue. Anyone suffering such a puncture wound should be **immediately** taken to a hospital emergency room to determine the extent of the injury. Explain the circumstances of the injury to the attending physician, including what kind of Hydraulic Fluid was involved. Do not assume a puncture wound that could have been caused by Hydraulic Fluid is a minor issue; it could be life threatening.

31. Make an inspection of the Lift **before** using it. Check for damaged, worn, or missing parts. Do not use it if you find any of these issues. Instead, take it out of service, then contact an authorized repair facility, your dealer, or BendPak at **(877) 432-6627** or support@BendPak.com.

Symbols

Following are the symbols used in this manual:

 **DANGER** Calls attention to an immediate hazard that **will** result in injury or death.

 **WARNING** Calls attention to a hazard or unsafe practice that **could** result in injury or death.

 **CAUTION** Calls attention to a hazard or unsafe practice that could result in minor personal injury, product, or property damage.

NOTICE Calls attention to a situation that, if not avoided, could result in product or property damage.



Tip

Calls attention to information that can help you use your product better.

Liability Information

BendPak Inc. assumes **no** liability for damages resulting from:

- Use of the product for purposes other than those described in this manual.
- Modifications to the equipment without prior, written permission from BendPak Inc.
- Injury or death caused by modifying, disabling, overriding, or removing safety features.
- Damage to the equipment from external influences.
- Incorrect operation of the equipment.

Components

The components of your Lift include:

- **Power Post.** The Post that holds the Power Unit. ***The Power Post can be in either of two locations.*** You can identify the Power Post from the other Posts because it has two Mounting Brackets on it. Mount the Power Unit on one of the two Mounting Brackets.
- **The other three Posts.** These Posts are interchangeable.
- **Power Unit.** *Not shown.* An electric/hydraulic unit that connects to an electric power source and then provides Hydraulic Fluid to the Hydraulic Cylinder that raises and lowers the Runways.
- **Powerside Runway.** On the same side as the Power Post. The Powerside Runway has the Hydraulic Cylinder and the Lifting Cables under them. The Powerside Runway ***must*** go next to the Power Post.
- **Offside Runways.** The three other Runways do not have a Hydraulic Cylinder or Lifting Cables under them. The two inner Runways can be moved to accommodate different Vehicle widths.
- **Flex Tube.** *Not shown.* A flexible, black tube that attaches to an opening on the Powerside Runway on one end and attaches by the Power Unit on the other end. Used for routing the Air Line, Return Line, and Hydraulic Hose to the Power Unit.
- **Crosstubes.** Goes at each end of the Lift. The Crosstubes are hollow; the Lifting Cables that raise and lower the Runways are routed through the Crosstubes. The Crosstubes are *not* interchangeable: Each Crosstube has an opening (called a “Window”) that faces the inside. ***Make sure to install the Lift so the Windows open to the inside of the Lift only.***
- **Stop Blocks.** The Inner Runways can be adjusted to fit different Vehicle widths; the Stop Blocks prevent the two middle Runways from moving too inward. Two Stop Blocks on each Crosstube.
- **Drive-up Ramps.** Use them to drive onto and off the Runways.
- **Tire Stops.** Located at the Front of the Lift, Tire Stops prevent the Vehicle’s front Tires from going any further forward. Additionally, we strongly recommend chocking the Vehicle’s rear Tires.
- **Safety Locks.** Once engaged, they hold the Runways in position, even if the power goes out or there is a leak in the Hydraulic Hoses. Your Lift has a column of Safety Locks in each Post, spaced every four inches. This lets you lock the Runways at just the right height for what you want to do. This Lift also has a backup Slack Safety system; refer to **About Safety Locks** for more information. ***Only leave your Lift on the ground or engaged on a Safety Lock.***
- **Pushbutton Air Valve.** *Not shown.* Includes a Pushbutton that moves the Safety Locks away from the Ladder so that they do not engage as you lower the Runways. Used only to lower the Runways. Usually located next to the Power Post.
- **Ladders.** Part of the safety system, installed at the back of each Post; resembles a ladder.

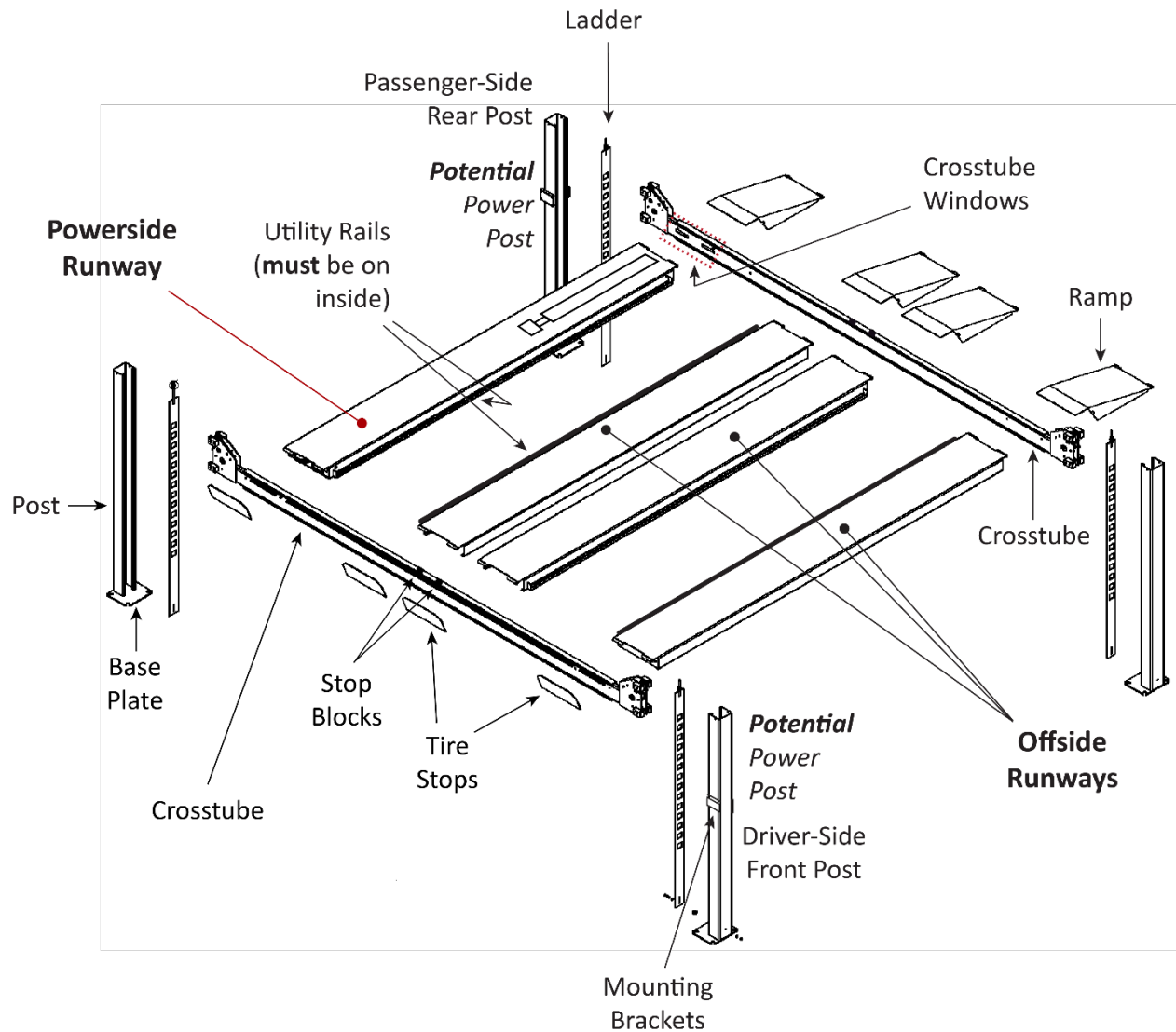

HD-9SW model shown.

Optional Accessories

There are additional products you can purchase separately for your Lift:

- **Aluminum Platforms.** Aluminum Platforms fill in the open space between the Lift's two runways, great for holding light storage items. See the [Aluminum Platforms page on the BendPak website](#) for more information.
- **Caster Kit.** The Caster Kit allows you to pick up and move your Four Post Lift without needing to disassemble it first, giving you the most out of your workspace. See the [Caster Kit page on the BendPak website](#) for more information.
- **Plastic Drip Trays.** Plastic Drip Trays prevent liquids from falling onto your Vehicle or work area. See the [Plastic Drip Trays page on the BendPak website](#) for more information.

Frequently Asked Questions

Question: What kinds of Vehicles can I put on my Parking Lift?

Answer: Cars, trucks, SUVs; anything that fits on the Runways. ***The combined weight for both Vehicles on the Runways cannot exceed 9,000 lbs*** (4,082 kg).

Q: Can any of the four Posts be the 'Power Post'?

A: No; the only two possible locations for the Power Post are either the *Front Driver-Side* or the *Rear Passenger-Side*. This will be explained later.

Q: Does the Lift have to be anchored in place?

A: **Yes**, this Lift is different than most Four-Post Lifts in the sense that it can raise two Vehicles on the Runways, so you want to make sure the Lift is secured in place.

Q: How can my Lift accommodate different Vehicle widths on the Runways?

A: The two Inner Runways can be easily adjusted between narrow and wide settings; there are two tabs in the middle of the Crosstubes to prevent the inner Runways from sliding too far inside. To adjust the Runways, slide it over to the appropriate distance.

Q: Can I use my Lift to hold storage boxes instead of a Vehicle?

A: No. This is not the intended use of the Lift; do **not** use it this way.

Q: How high does the ceiling need to be?

A: It depends on the height of the Vehicles you are putting on the Runways and how high you raise the Runways. If you are going to put a tall Vehicle on the Lift and raise it all the way up, you should check to make sure there is enough room.

Q: Does it matter if I drive my Vehicles in front first or back them in?

A: We strongly recommend driving your Vehicles in front first, because that makes it easier to center the Vehicle's wheels on the Runways. Also, remember to put the front wheels up against the Tire Stops and chock the rear wheels.

Q: How many Safety Locks does my Lift have?

A: Depending on the model you have; your Lift has either 14 or 17 Safety Locks for you to use.

Q: How long can I leave a Vehicle on a raised Runway?

A: As long as you want; once the Lift is engaged on a Safety Lock, gravity holds it in position, so a loss of power does not impact it; it is going to stay where you left it. ***Always leave the Platforms either fully lowered or engaged on a Safety Lock.***

Q: Can I install my Lift outside?

A: Your Lift is approved for indoor installation and use only. Outdoor installation is prohibited.

Specifications

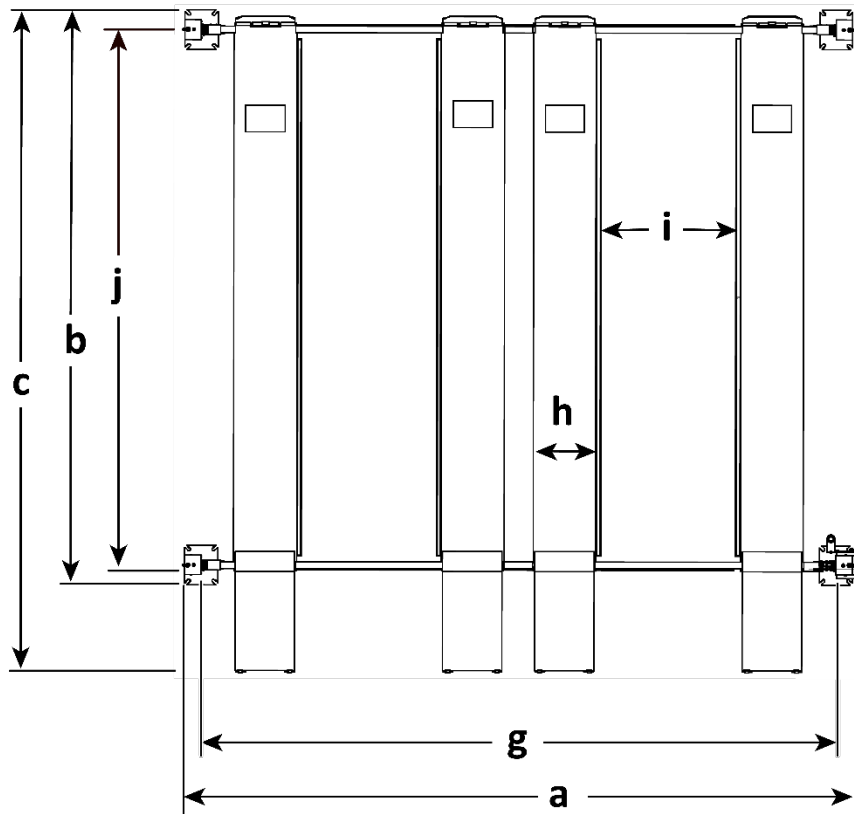
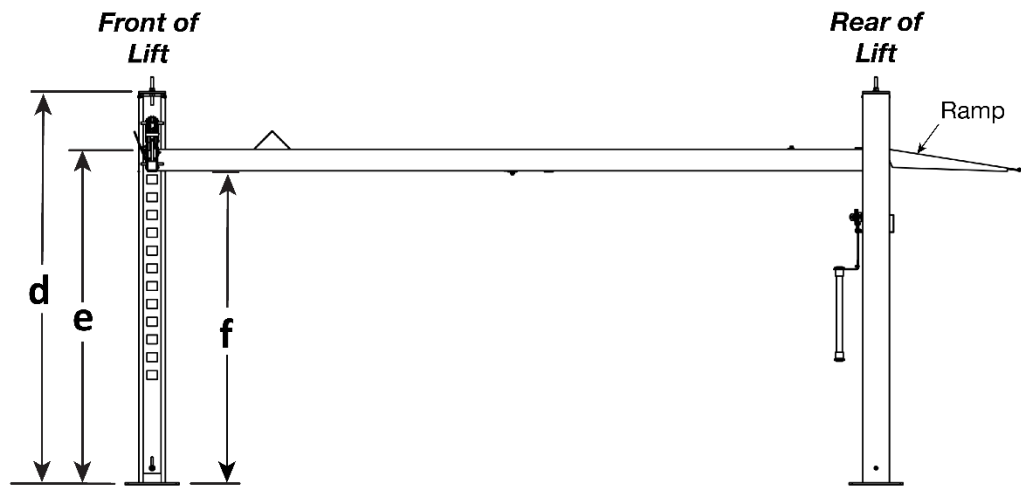

Model	HD-9SW	HD-9SW-E	HD-9SWX
Lifting capacity ¹	9,000 lbs. / 4,082 kg		
a Overall width ²	202" / 5,131 mm	249.60" / 6,339 mm	202" / 5,131 mm
b Outside length	174" / 4,418 mm		198" / 5,028 mm
c Overall length	200.5" / 5,095 mm		224.5" / 5,705 mm
d Post height	90" / 2,282 mm		102" / 2,587 mm
e Maximum rise	77" / 1,957 mm		89.06" / 2,262 mm
f Maximum lifting height	72.3" / 1,836 mm		84.29" / 2,141 mm
g Distance between Posts	192" / 4,877 mm	238" / 6,046 mm	192" / 4,877 mm
h Runway width	19" / 482 mm		
i Width between Runways	34.30" <i>min.</i> – 41" <i>max.</i> 871 mm – 1,039 mm		
j Runway length	164.5" / 4,178 mm		188.50" / 4,788 mm
Min. wheelbase @ rated capacity ³	115" / 2,921 mm		135" / 3,429mm
Min. wheelbase @ 75 capacity ³	100" / 2,540 mm		115" / 2,921 mm
Min. wheelbase @ 50 capacity ³	85" / 2,159 mm		95" / 2,413 mm
Min. wheelbase @ 25 capacity ³	70" / 1,778 mm		80" / 2,032 mm
Locking positions	14; spaced every 4" / 102 mm		17; spaced every 4" / 102 mm
Lifting time	55 seconds		65 seconds
Motor	220 VAC, 60 Hz, 1 Ph (<i>special voltages available upon request</i>)		

- ¹ The **combined weight** for **both Vehicles** on the Runways **cannot** exceed 9,000 lbs.
- ² Overall Width is defined as the dimension outside-to-outside of the Baseplates. Use the Overall Width listed here for creating chalk lines.
- ³ The Runways supports less weight than its rated capacity if the Vehicle's wheelbase is shorter; this is because the wheels are closer to the middle of the Runways, where there is less strength. For example, the maximum weight allowed on the Lift for a Vehicle with a wheelbase of 85" is 50 percent of the Lift's rated capacity (or 4,500 lbs when the rated capacity is 9,000 lbs).

Specifications subject to change without notice.

Installation Checklist

Following are the steps needed to install your Lift. Perform them in the order shown.

- 1. Review the safety rules.
- 2. Make sure you have the necessary tools.
- 3. Plan for electrical work.
- 4. Select the installation location.
- 5. Check the Clearances.
- 6. Decide the Lift Orientation.
- 7. Unload and unpack the Lift components.
- 8. Create Chalk Line Guides.
- 9. Move the Posts into position.
- 10. Install the Crosstubes.
- 11. Learn about Safety Locks.
- 12. Install the Ladders and Top Caps.
- 13. Raise the Crosstubes.
- 14. Secure the Ladders.
- 15. Removing the Sheaves.
- 16. Install the Runways.
- 17. Route the Lifting Cables.
- 18. Read about Working with Compression Fittings and Tubing.
- 19. Install the Air Line.
- 20. Read about Thread Sealant.
- 21. Install the Return Line.
- 22. Install the Hydraulic Hose.
- 23. Install the Power Unit.
- 24. Install the Flex Tube Bracket Plate and Angle Plate.
- 25. Install the Flex Tube.
- 26. Install the Pushbutton Air Valve and connect the Air Lines.
- 27. Connect the Return Line.
- 28. Connect the Hydraulic Hose.
- 29. Contact the Electrician.
- 30. Connect to a power source (**Electrician required**).
- 31. Install the Power Disconnect Switch and Thermal Disconnect Switch (**Electrician required**).
- 32. Learn about Effective Embedment.
- 33. Anchor the Posts.
- 34. Perform final leveling.
- 35. Install the Accessories.
- 36. Install Anti-Slip Tape.
- 37. Lubricate the Lift.
- 38. Test the Lift.
- 39. Review the final checklist.
- 40. Leave the manual for the owner/operator.

Installation

The installation process requires multiple steps. Perform them in the order listed. **Read the entire *Installation section before beginning the install***, this gives you a better understanding of the process as a whole.

⚠ WARNING **Only use the factory-supplied parts that came with your Lift.** If you use parts from a different source, you void your warranty and compromise the safety of everyone who installs or uses the Lift. If you are missing parts, visit bendpak.com/support or call **(800) 253-2363**, extension 191.

Safety Rules

While installing this equipment, your safety depends on proper training and thoughtful operation.

⚠ WARNING Do not install this equipment unless you have automotive Lift installation training. Always use proper lifting tools, such as a Forklift or Shop Crane, to move heavy components. Do not install this equipment without reading and understanding this manual and the safety labels on the unit.

Only fully trained personnel should be involved in installing this equipment. Pay attention at all times. Use appropriate tools and lifting equipment. Stay clear of moving parts.

BendPak recommends referring to the ANSI/ALI ALIS Standard (R2015) *Safety Requirements for Installation and Service* for more information about safely installing, using, and servicing your Lift.

⚠ WARNING You **must** wear OSHA-approved (publication 3151) personal protective equipment at all times when installing, using, maintaining, or repairing the Lift: leather gloves, steel-toed boots, eye protection, back belts, and hearing protection are **mandatory**.

Using Tools

You may need some or all of the following tools:

- Rotary hammer drill or similar
- 3/4 inch carbide bit (conforming to ANSI B212.15)
- Hammer and crowbar
- Four-foot level
- Open-end wrench set, SAE and metric
- Socket and ratchet set, SAE and metric
- Hex key wrench set
- Medium crescent wrench, torque wrench, pipe wrench
- Chalk line
- Medium-sized flat screwdriver and needle-nose pliers
- Tape measure (25 feet or above)
- Forklift, Shop Crane, or heavy-duty rolling dolly, and two sawhorses
- 12-foot ladder

Selecting a Location

When selecting the location for your Lift, consider:

- **Architectural plans.** Consult the architectural plans for your desired installation location. Make sure there are no issues between what you want to do and what the plans show.
- **Available space.** Make sure there is enough space for the Lift: front, back, sides, and above. Refer to **Specifications** for measurements.
- **Overhead Clearance.** Check for overhead obstructions such as building supports, heaters, electrical lines, low ceilings, hanging lights, and so on. ***You do not want the Vehicles on the Lift hitting obstructions.***
- **Side Clearances.** You must leave room around the Lift. Leave at least three feet (36 inches) clear on the sides of the Lift.
- **Front and Rear Clearances.** You must leave room around the Lift. Leave at least two feet (24 inches) clear on the Front of the Lift, and no obstructions at all at the Rear of the Lift so you can safely drive Vehicles on and off the Runways.
- **Power.** You need a 220 VAC power source available for the Power Unit.
- **Outdoor installations.** Your Lift is approved for indoor installation and use ***only***.
- **Floor.** Only install the Lift on a flat, concrete floor; do not install on asphalt or any other surface. The surface must be level; do not install if the surface has more than 3° of slope.

 **WARNING** Installing a Lift on a surface with more than 3° of slope could lead to injury or even death; only install the Lift on a level floor. If your floor is not level, consider making the floor level or using a different location.

- **Shimming.** If your concrete floor is not completely level, you can use Shims under the Bases of the Posts, as needed, to level the Lift. To estimate your Shim requirements, use a transit level to check for flatness. Use the provided Shims as necessary.

NOTICE Do not shim a Post more than half an inch using the provided Shims and Anchor Bolts. A maximum shim of 2 inches is possible by ordering optional Shim Plates. Contact BendPak at **(800) 253-2363**, extension 191 to order.

- **Concrete Specifications.** Do not install the Lift within 6 inches of expansion seams and cracked or defective concrete. Make sure the concrete is at least 4.25 inches thick, 3,000 psi, and cured for a minimum of 28 days. A minimum concrete reinforcement using Welded Wire Mesh is recommended (6 x 6 – 10 WWF).

 **CAUTION** BendPak Lifts are supplied with installation instructions and Concrete Anchors that meet the criteria set by the current version of the American National Standard “Automotive Lifts – Safety Requirements for Construction, Testing, and Validation”, ANSI/ALI ALCTV. You are responsible for any special regional structural and/or seismic anchoring requirements specified by any other agencies and/or codes such as the Uniform Building Code (UBC) and/or International Building Code (IBC).

Be sure to check your floor for the possibility of it being a post-tension slab. In this case, you must contact the building architect before drilling. Using ground penetrating radar may help you find the tensioned steel.

 **WARNING** Cutting through tensioned Cable can result in injury or death. Do not drill into a post-tension slab unless the building architect confirms you are going to hit tensioned steel, or you have located it using ground penetrating radar. ***If colored sheath comes up during drilling, stop drilling immediately.***

- **Multi-Lift installations.** In a Multi-Lift layout, there must be a minimum spacing of 5 inches from the edge of the Baseplates of the first Lift to the edge of the Baseplates on the next Lift.

 **WARNING** Installing a Lift closer than 5 inches from the next Lift compromises the holding strength of the Anchor Bolts; make sure there is enough spacing between the Lifts.

Planning for Electrical Work

You will need to have a licensed, certified Electrician available at some point in the installation.

 **DANGER** All wiring ***must*** be performed by a licensed, certified Electrician.

Notify your Electrician in advance so that they come prepared with an appropriate Power Cord with a Plug for connecting to the power source, a Power Disconnect Switch, and a Thermal Disconnect Switch. Refer to **Contacting the Electrician** for more information.

Your Electrician needs to:

- **Connect the Power Unit to an electric power source.** An electric power source is required. The Power Unit comes with a pigtail for wiring to a power source. Have your Electrician *remove* the pigtail and wire from inside the Electrical Box on the Power Unit to a Power Cord and Plug or have them wire it directly into the electrical system at the Lift location.

Note: *Installing* the Power Unit and *connecting* the Power Unit to the power source are separate procedures and are completed at different times in the installation process. You do not need an Electrician to install the Power Unit, but an Electrician is ***required*** to connect the Power Unit to the power source.

- **Install a Power Disconnect Switch.** Ensures you can quickly and completely interrupt electrical power to the Lift in the event of an electrical circuit fault, emergency situation, or when equipment is undergoing service or maintenance. Put it within sight and reach of the Lift operator.
- **Install a Thermal Disconnect Switch.** Ensures the equipment shuts down in the event of an overload or an overheated motor.

Selecting the Lift Orientation

Before going any further, decide how you want to orient your Lift. This decision affects where you will place your Power Post and also the positioning of the Runways, which are **not** interchangeable.

One Runway has the Hydraulic Cylinder underneath it and is the starting point for the Lifting Cables; the other Runways do not have anything underneath them. The Runway with the Hydraulic Cylinder is the Powerside Runway and **must** be installed next to the Power Post (which holds the Power Unit).

You can choose to position your Power Post at either the **Front Driver-Side** or the **Rear Passenger-Side**, as shown below.

Important: Installers, you need to have the Lift owner make this decision no later than when moving the Posts into position.

The drawings in this manual show the Power Post at the **Rear Passenger-Side**, but that does not mean you have to. In many cases, the main factor is the location of the power source; many customers prefer to place their Power Post (which holds the Power Unit), near the power source. If power is not an issue, choose the option below that best fits your setup.

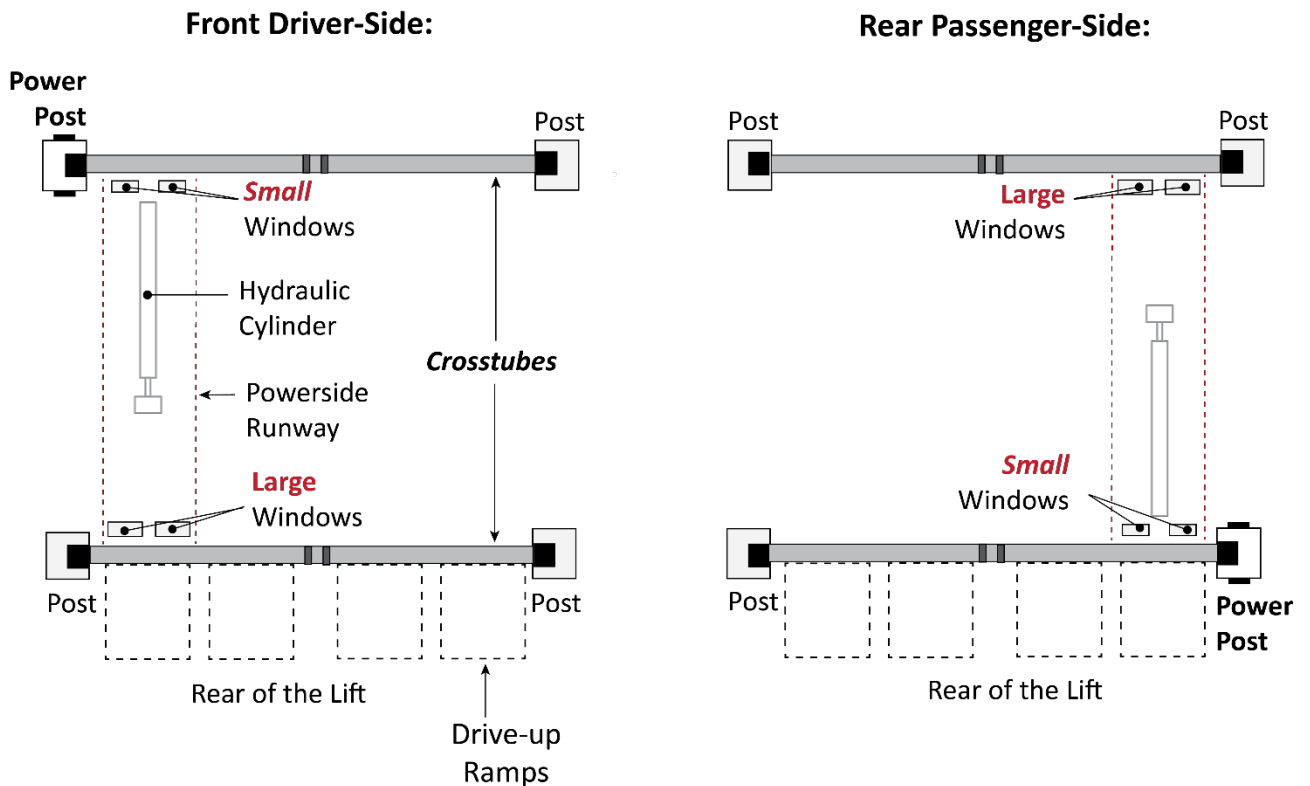

Note: Windows are shown away from Crosstubes for clarity.

Top View. Drawing not to scale. Not all components are shown.

Creating Chalk Line Guides

Create the Chalk Line Guides so that the outside edges of all four Posts fit into the four corners created by the Chalk Line Guides.

See **Specifications** to determine the **Overall Width** and **Outside Posts Length** values for your Lift model.

Note: Do *not* use the **Overall Length** value; this includes the Ramps, which are not taken into consideration for creating Chalk Line Guides.

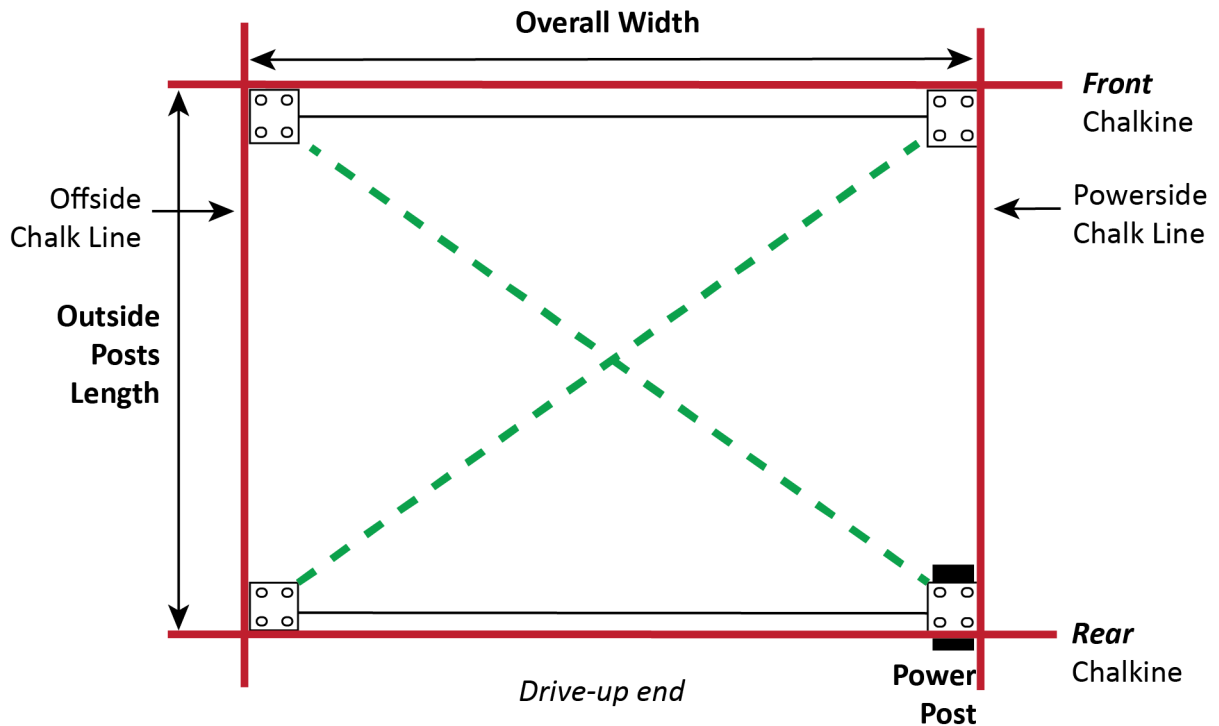

To create Chalk Line Guides:

1. Create the Front Chalk Line where you want the Front of the Lift.
Make the Front Chalk Line *longer* than the Total Width setting for your Lift.
2. Create the Powerside and Offside Chalk Lines at 90° angles to the Front Chalk Line and parallel to each other. Make the Powerside and Offside Chalk Lines *longer* than the Outside Posts Length setting for your Lift model.
3. Create the Rear Chalk Line parallel to the Front Chalk Line. Make the Rear Chalk Line *longer* than the Total Width setting for your Lift model.
4. Before moving the Posts into position, measure **diagonally** to make sure the two diagonal measurements are the same. This ensures your layout is correct.
Do not forget to check the diagonals.
5. When you move the Posts into position, put the corners of the Base Plates **inside** the corners created by the four Chalk Lines.

Unloading and Unpacking

Once the components are unloaded, they are your responsibility to move around. As the Lift includes a number of heavy pieces, the closer you unload them to the installation location, the better off you are.

⚠ CAUTION Some Lift components are very heavy; if handled incorrectly, they can damage materials like tile, sandstone, and brick. Try to handle the Lift components twice: once when delivered and once when moved into position. You must have a Forklift or Shop Crane to move them into position. Use care when moving them.

⚠ WARNING The Posts and Runways are delivered with stabilizing structures on each end. Be very careful when removing these stabilizing structures; the Posts and Runways can shift or even fall. If they fall on a person, they could cause serious injury.

At this point in the installation, we recommend removing the two Cable Sheaves on each end of the Powerside Runway. Because of the way the Lift components are packaged, you may need to shift the Crosstubes slightly in order to access the underside of the Powerside Runway. When you remove the Sheaves, **keep all the components together**. You will be reinstalling them later in the installation at the same location, using the same components.

Front of Runway:

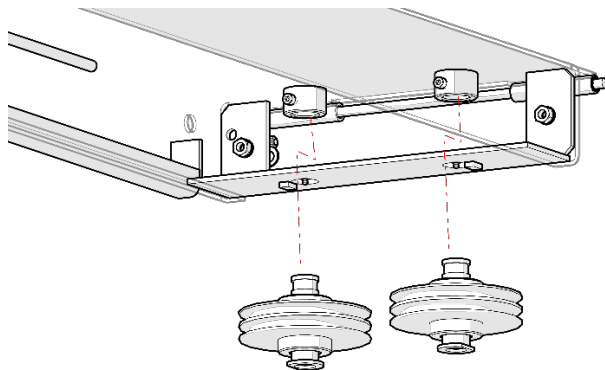

Rear of Runway (Cylinder end):

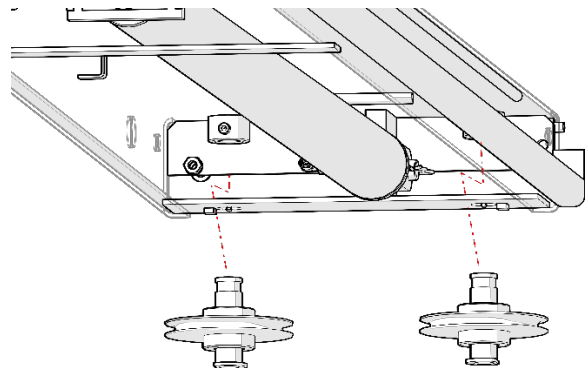

Moving the Posts into Position

Use a Forklift or Shop Crane to move the Posts, one at a time, to the inside corners of the Chalk Line Guides.

Important: Position the Power Post at your chosen location. Remember, the Power Post can only go in two possible locations: the **Front Driver-Side** or the **Rear Passenger-Side**. The other three Posts can go at any of the remaining Post locations. Refer to **Lift Orientation** for more information.

Do not stand up the Posts yet, some of the following procedures are easier to complete if the Posts are laying on the ground.

Installing the Crosstubes

Your Lift has two Crosstubes:

- **Crosstube with Large Windows:** Goes on the end of the Lift opposite of the Power Post, with the Windows facing the inside. Holds 2 Double Cable Sheaves.
- **Crosstube with Small Windows:** Goes next to the Power Post, with the Windows facing the inside. Holds 2 Single Cable Sheaves.

Important: It is possible to install the Crosstube **incorrectly** in several different ways. Take your time now and get it right the first time.

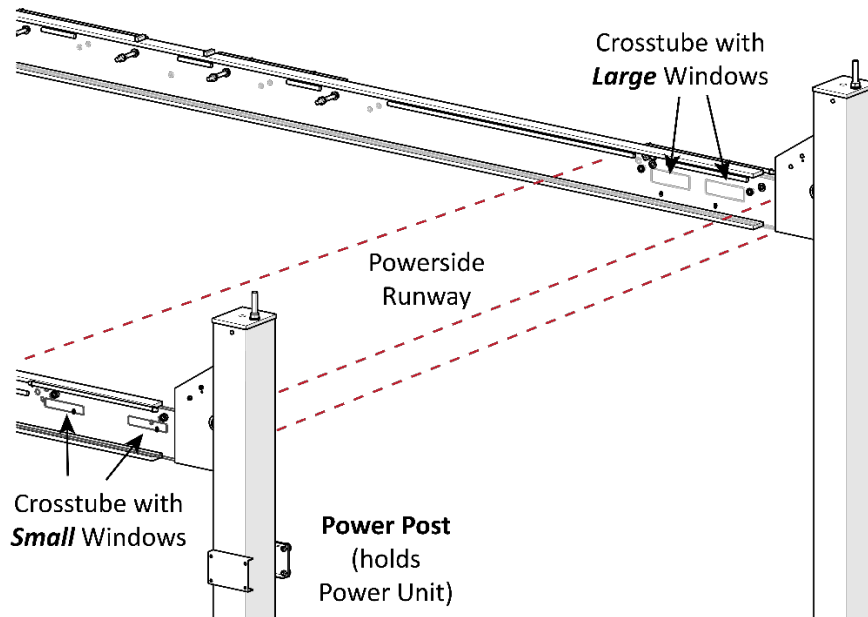

Top View. Windows are in the Crosstubes; drawing shows how to properly orient the Crosstubes.

*Drawing positions the Power Post in the **Rear Passenger-side** location.*

Drawing not to scale. Some components not shown.

To install the Crosstubes:

1. Orient the Crosstubes in their required locations:
 - Crosstube with Small Windows **must** be adjacent to the Power Post.
 - Both Windows **must** be on the ends of the Powerside Runway and facing the **inside** of the Lift.
2. Put the black Slide Blocks into place on the outside ends of each Gusset (4 Blocks per Gusset).

Align the holes in the Slide Blocks with the rods on the side of the Gusset, then press the Slide Blocks in. Make sure the Slide Blocks are oriented so that they create a Slot when pushed in.

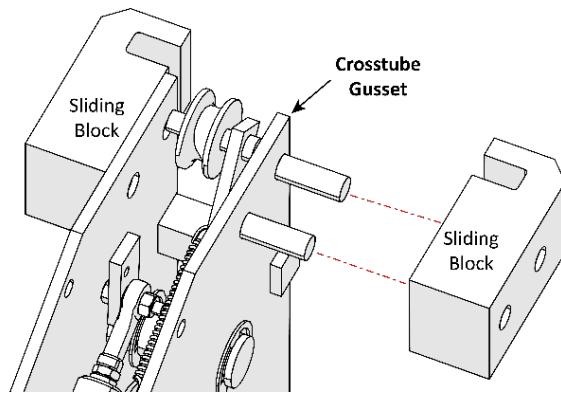

Top View. Drawing shows how to correctly install two Slide Blocks onto the Crosstube Gusset.

Not all components are shown.

The four Slide Blocks on a Gusset, when put into place, create two Slots about four inches wide and half an inch deep. There is one Slot at the top of the Gusset and a second Slot at the bottom; the Ladder **must** go through **both** Slots on the Gusset.

⚠ WARNING If the Slide Block are not correctly installed, then the Slots for the Ladder are not created. In such case, the Safety Locks will not work correctly, which endangers everyone who uses the Lift. Make sure to correctly install the Slide Blocks.

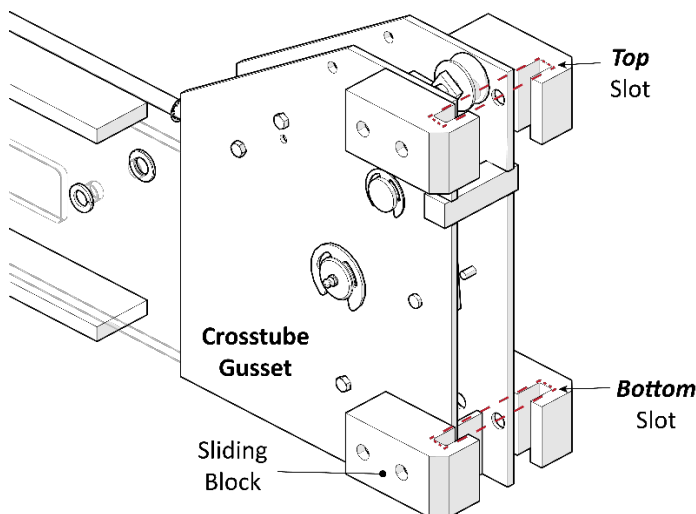

Front View. Drawing shows the Top and Bottom Slots created by the Slide Blocks.

Not all components are shown.

3. Lean over the two Posts at one end of the Lift (some people put them on sawhorses, some people lay them on the ground), slide the Crosstubes into place, then carefully stand up the Posts; make sure to put them back in their correct locations inside the Chalk Line guides.

Or

Carefully stand up the Posts, use a Forklift or Shop Crane to raise the Crosstube above the top of the two Posts that it goes between, and then slide the Crosstube down into place.

⚠ WARNING Use care when installing the Crosstubes, as the Posts are not anchored in place at this point. Dropping or knocking over the Posts may cause permanent equipment damage or serious personal injury. The Crosstubes and Posts are heavy; do not lift without assistance.

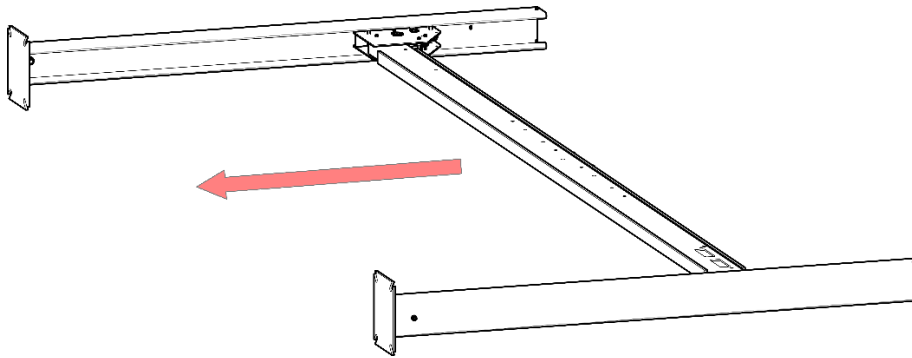

4. Perform Steps 2 and 3 for the other Crosstube.

About Safety Locks

Safety Locks hold the Runways in place. Once in place, Safety Locks hold the Runways in place, even if the Power goes out or the Hydraulic Hoses break or leak. The Safety Locks are spaced every four inches / 100 mm. Each Post has its own Ladder and set of Safety Locks.

Important: Simply raising the Runways does not engage them on the Safety Locks. You must back the Runways down onto the Safety Locks to engage them.

⚠️WARNING Safety Locks are dependent on correct installation of the Ladders. Pay careful attention when installing the Ladders, thus ensuring correct operation of the Safety Locks on your Lift.

The Ladders, one per Post, are steel pieces with holes spaced every four inches / 100 mm. As you raise the Runways, the Safety Locks move into the holes in the Ladder. When you move the Runways back down a little after passing a Safety Lock, the Safety Lock engages. Once they are engaged, Safety Locks stay engaged until you are ready to lower the Runways.

⚠️WARNING Always leave the Runways either fully lowered or engaged on their Safety Locks. When you engage the Safety Locks at a desired height, check to make sure that all four Safety Locks are engaged.

So how do the Runways come down if the Safety Locks are engaged? To lower the Runways, you raise them a few inches (to get them off the Safety Locks), then **press and hold down** the pushbutton on the Pushbutton Air Valve. While you hold down the pushbutton, the Safety Locks are moved away from the Ladders; they cannot engage, which allows the Runways to be lowered.

Out of an abundance of caution, your Lift has a second, independent Safety Lock system called the Slack Safety. In total, your Lift has two Safety systems:

- **Primary Safety Locks:** The primary system to hold up the Runways on your Lift are the Safety Locks. When you move the Runways up, you can hear clicks as the Safety Locks go into the holes in the Ladders. When you want to keep the Runways at a certain height, you go slightly past the height you want, then back the Safety Locks down into the holes in the Ladders, which engages them.
- **Slack Safety Locks:** The Slack Safeties are next to the Safety Locks on the ends of the Crosstube Gussets. They are different from the Safety Locks in that when the Cables are taut (which they are during normal operation), they hold the Slack Safeties away from the Ladder so that the Slack Safeties cannot engage. However, if a Cable were to break (which very rarely

happens), the Slack Safety for the broken Cable immediately engages, preventing the Runways from falling.

Installing the Ladders and Top Cap

Each Post has a Ladder, each gets installed on the inside back of a Post; Ladders are secured at the top and the bottom.

The Top Caps secure the Ladder at the top of each Post and hold the ends of the Cables.

Note: It is much easier to secure the bottom of the Ladders once the Crosstubes have been raised, so that portion of installing the Ladders is described in **Securing the Ladders**.

⚠ WARNING Make sure to install the Ladders correctly. If they are not installed correctly, the Safety Locks on your Lift may not hold the weight of a vehicle, putting anyone under the Lift in danger.

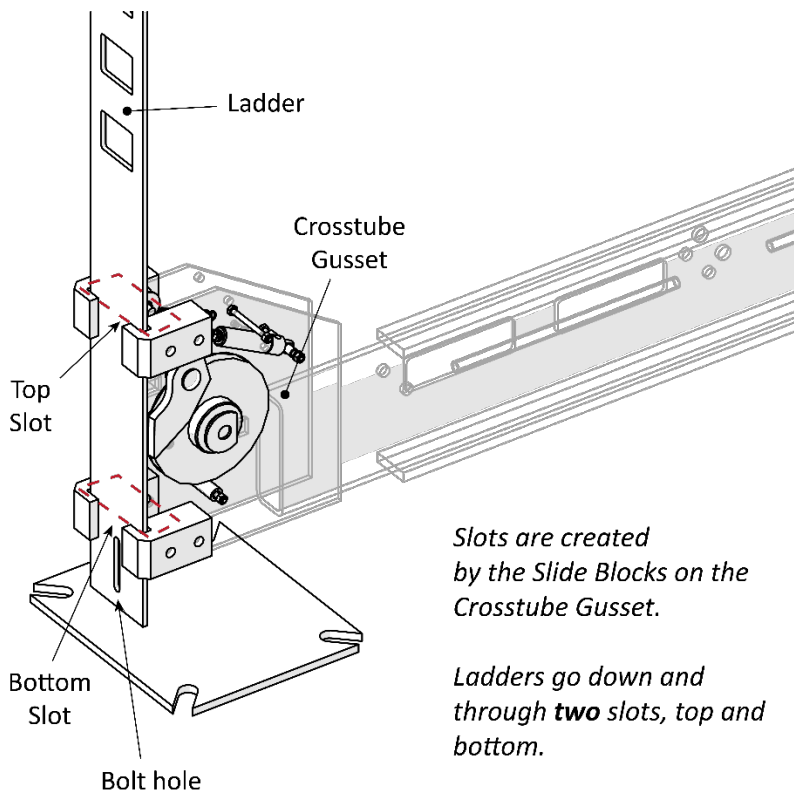

Drawing shows how to route the Ladders through both Slots created by the Slide Blocks.

Not all components shown. Post not shown for clarity.

Slots are created by the Slide Blocks on the Crosstube Gusset.

*Ladders go down and through **two** slots, top and bottom.*

Post not shown in graphic.

To install the Ladders and the Top Caps:

1. Take a Ladder and slide it down the back of the Post, Bolt Hole end at the bottom.

Make sure the Ladder goes through both Slots on each Gusset. There is a Slot at the top of the Gusset and another Slot at the bottom of the Gusset, formed by the Slide Blocks.

⚠ WARNING It is easy to see the top Slot created by the Slide Blocks. It is difficult to see the bottom Slot, but it is **required** that the Ladder goes through both Slots. If the

Ladder misses a Slot or the Slide Blocks were not installed correctly, your Safety Locks will **not** function correctly.

2. Install the remaining Ladders the same way.
3. **Moving to the top of the Ladders**, put a Stop Nut on the Threaded Bolt at the top; move it half of the way down towards the top of the Ladder.

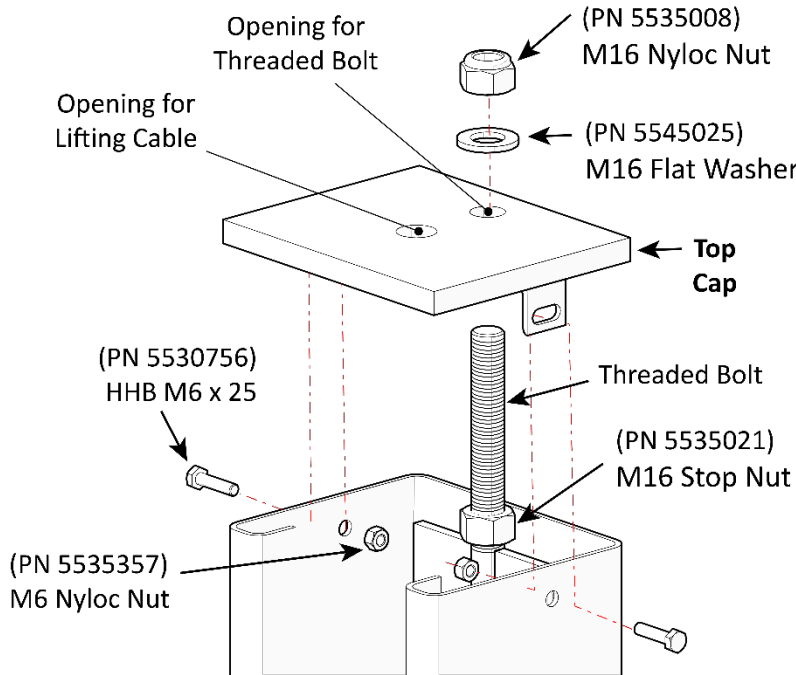

Drawing shows connections to make to the Top Cap, near the top of the Posts.

Not all components shown.

4. Put the Top Cap onto the top of the Post: put the Threaded Bolt on the top of the Ladder through the appropriate hole, put the tabs on the side of the Top Cap inside of the Post, and secure the Top Cap on both sides with a Hex Head Bolt and a Nyloc Nut on each side.
5. Once the Top Cap is secure, move the Stop Nut up until it contacts the underside of the Top Cap, then add a Flat Washer and Nyloc Nut to the top of the Top Cap and tighten it.

You are looking for about **1 inch / 25 mm** of thread above the top of the Top Nut.

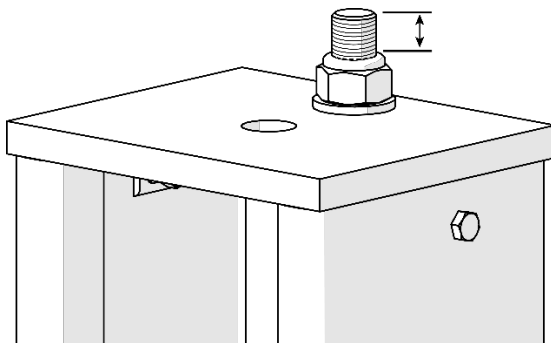

Drawing shows the threads to rise above the Top Nut. Adjust as needed.

Not all components are shown.

Note: Do not securely tighten the Top Nut at the Top Cap at this point; it can be securely tightened after you do the final leveling to the Lift.

6. Install the remaining Top Cap the same way.

Raising the Crosstubes

You need to manually raise the Crosstubes, which makes it easier to complete the rest of the installation tasks. Both Crosstubes need to **be raised to the same height, to the same Safety Lock**.

⚠ WARNING Use care when raising the Crosstubes, as the Posts are not anchored in place at this point. Dropping or knocking over the Posts may cause permanent equipment damage or serious personal injury. The Crosstubes and Posts are heavy; do not lift without assistance. BendPak strongly recommends having at least two people work together to raise the Crosstubes.

To raise the Crosstubes:

1. Using a Forklift or Shop Crane, *carefully* raise each Crosstube at least two feet off the ground to facilitate Lifting Cable routing.

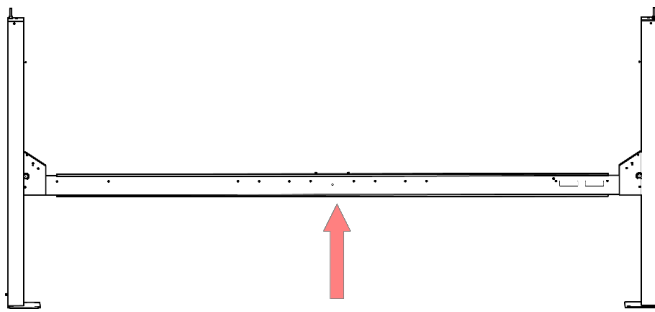

Important: The Slack Safeties cannot be engaged as you continue with the installation. Because the Lifting Cables are not in place yet, the Slack Safeties are going to engage when you manually raise the Crosstubes. You need to disengage them after you have raised the Crosstubes. The Primary Safeties are not impacted; they will engage normally when you manually raise each Crosstube, which is what you want.

2. To disengage the Slack Safeties after raising a Crosstube, press the Sheave Assembly (they are connected and will move together) back towards the Ladder and the back of the Post.

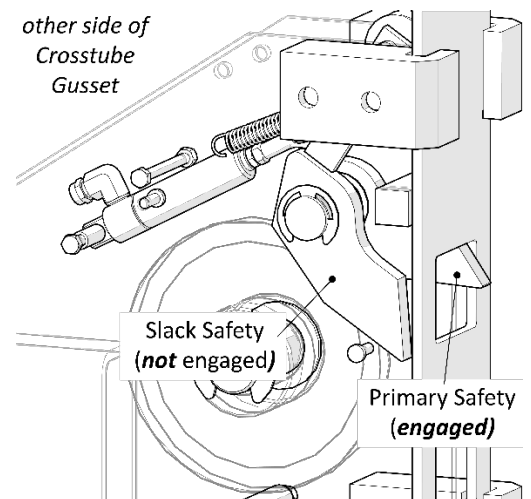
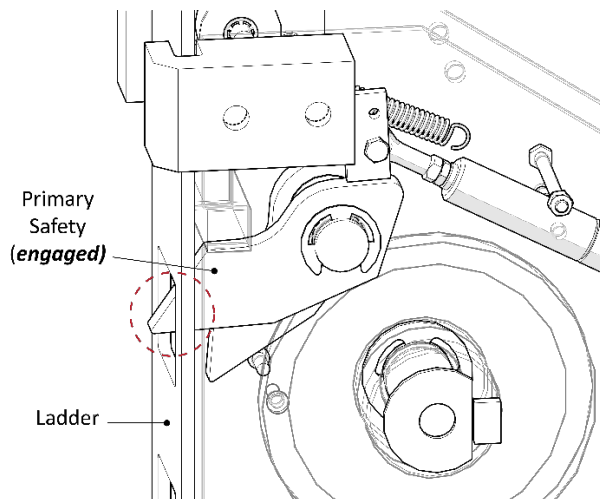

- Once both Crosstubes are in position, **all Primary Safeties are engaged**, and the Slack Safeties have been disengaged, you can continue with the installation.

Securing the Ladders

Because it is much easier to secure the Ladders at the bottom of each Post **after** the Crosstubes have been raised, that procedure is described here.

The following procedure assumes that the Ladders are in place and secured at the top. If this is not the case, return to **Installing the Ladders**.

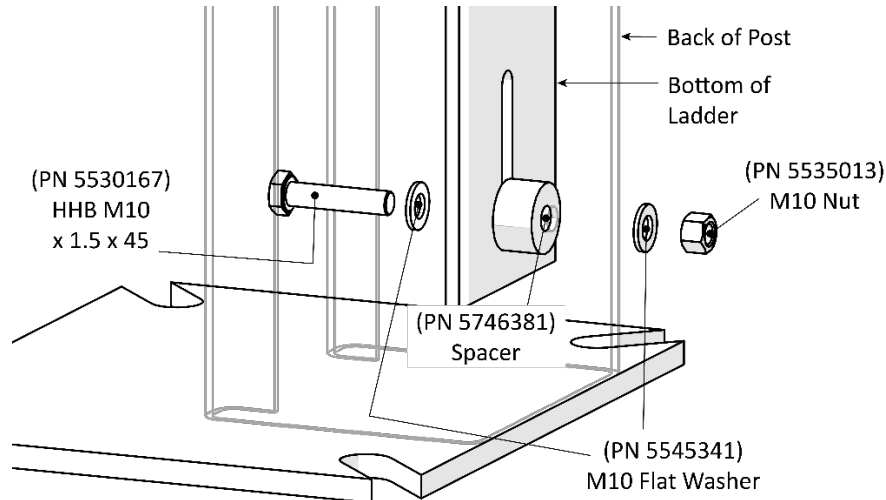

Front view. Drawing shows the connections to make to the bottom of the Post.

Not all components are shown. Some components stripped away for clarity.

To secure the Ladders:

- Locate the required 4 Bolts, 8 Washers, 4 Spacers, and 4 Nyloc Nuts.
- Secure the Ladder as shown in the graphic, making sure to orient the Spacer between the Ladder and the back of the Post.
- Perform the same procedure to secure the other three Ladders on the Lift.

Note: Do not securely tighten the Top Nut at the top of the Top Cap at this point. The Top Nut and the Stop Nut will be used later to make sure the Lift is level. They can be securely tightened after you do the final leveling; See **Final Leveling** for more information.

- Make sure the Primary Safety Locks are engaged.

WARNING Do not continue with the installation until you have visually confirmed that all four Primary Safety Locks are engaged. If they are not engaged, the Runways could move or fall, possibly causing injury (even death) or product damage.

- Stand up each Post. Have at least two people work together to stand up a Post.

CAUTION Use caution when walking around the Posts; they are not anchored at this point, so it is possible to knock them over, which could cause injury.

- Use a Transit Level to estimate the Shim requirements: use a target to find the difference in height between the Posts. The difference is the estimated amount of Shim thickness you will need. Do not use Shim and/or Anchor Bolts to shim more than 1/2 an inch.

Do not anchor the Posts at this point. You may or may not be anchoring the Posts at all, depending on whether or not you are going to use the optional Caster Kit. But even if you plan to anchor the Posts eventually, do not anchor the Posts now.

Installing the Runways

Your Lift has four Runways:

- **Powerside Runway:** Holds the Lift's Hydraulic Cylinder underneath. Has a hole on the outside (on Cylinder end) for routing the Hydraulic Hoses and Lines. **Must go next to the Power Post.**
- **Offside Runways:** Do not have Hydraulic Cylinders under them, nor are there any Cables under them. The two inner Runways can be moved to support different Vehicle widths.

The following drawing shows the correct orientation of the Runways.

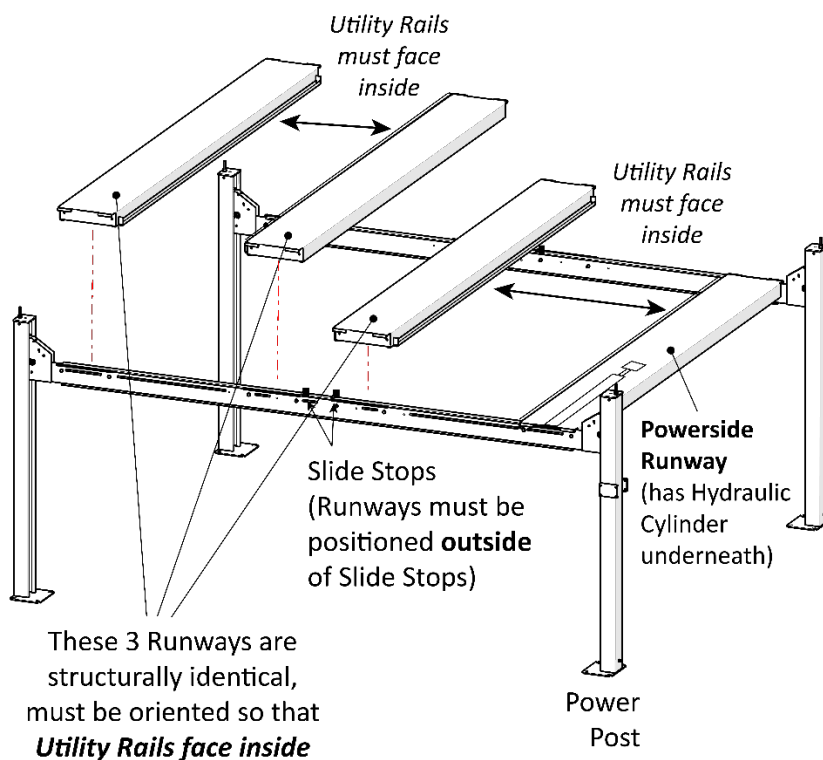

Top View. Cable Sheaves and Hydraulic Cylinder are located on the underside of the Powerside Runway.

*Utility Rails **must** face the inside of the Lift.*

Slide Stop size exaggerated in graphic for clarity. Not all components shown.

Use a Forklift or Shop Crane to raise the Runways and move them into position.

⚠ WARNING Pay close attention when moving the Runways into position; they are heavy and long, and could shift position or fall, potentially causing serious injury.

To install the Runways:

1. Correctly orient the Runways, as shown in the previous graphic.
2. Under the Powerside Runway, make sure the Sheaves have been removed.

Front of Runway:

Rear of Runway (Cylinder end):

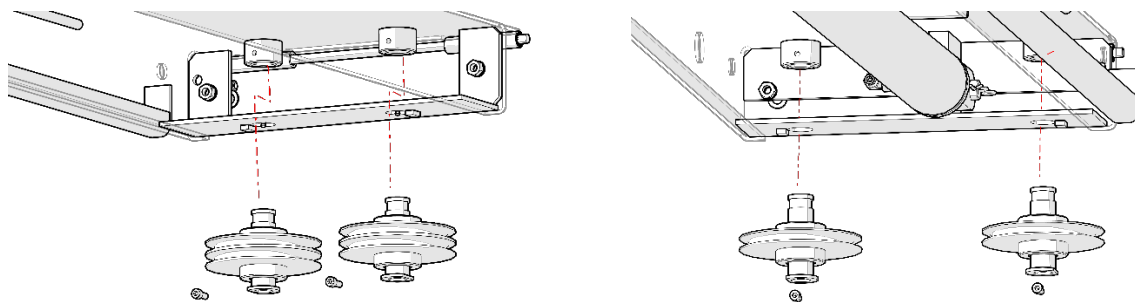

- Using a Forklift or Shop Crane, pick up the Runways separately, and move them to their correct locations on the Lift.

For the Inner Runways, Runways must be placed **outside** of the Slide Stops.

Make sure the Utility Rail is on the inside. See graphic on previous page for more information.

- Bolt the Runways into place, two Bolts on each end going into the Crosstubes.

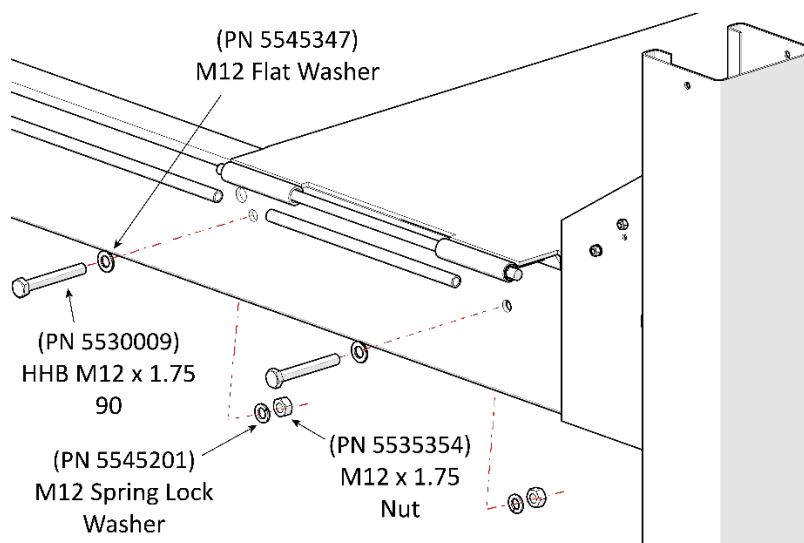

Drawing shows how to secure the Runways to the Crosstubes.

Two Bolts on each end of the Runway.

Not all components shown.

- Make sure the Primary Safety Locks are engaged.

⚠ WARNING Do not continue with the installation until you have visually confirmed that all four Primary Safety Locks are engaged. If they are not engaged, the Runways could move or fall, possibly causing personal injury (even death) or product damage.

- Locate the three Runway Straps from the Parts Box.

The Runway Strap is approximately 19 in. L x 2 in. W (472 mm x 50 mm) with a hole on either end.

- Align the holes on the Runway Strap with the holes underneath the Offside Runway, and then secure in place with a Bolt, Spacer, and Nut; repeat for the remaining Runway Straps.

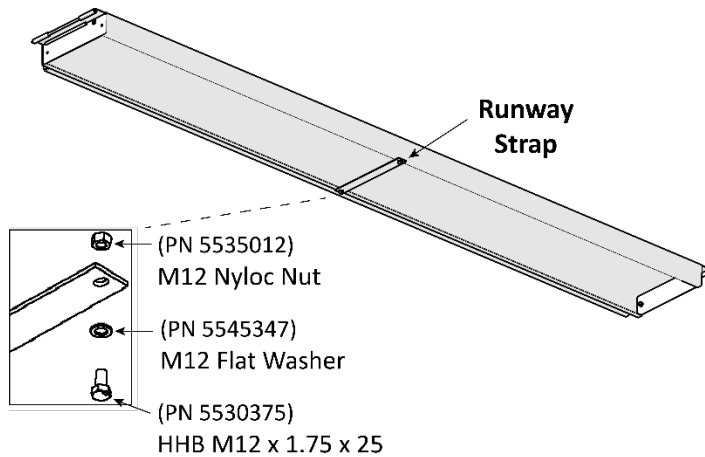

Drawing shows how to install the Runway Straps to the 3 Offside Runways.

The Powerside Runway already has a Runway Strap pre-installed.

Not all components of the Runway are shown.

Installing the First End of the Flex Tube

The Flex Tube is a flexible, black tube that attaches to a hole on the Powerside Runway on one end and to the bottom of the Flex Tube Bracket Plate (near the Power Unit) on the other end.

The Flex Tube consolidates and protects three lines that come out from under the Powerside Runway on their way to the Power Unit: The Air Line, the Return Line, and the Hydraulic Hose.

Installation of the Flex Tube is done in two parts: the first part is done after the Runways are installed (now), the second part after the Power Unit (and the Flex Tube Bracket Plate) is installed (later).

The following drawing shows the Flex Tube.

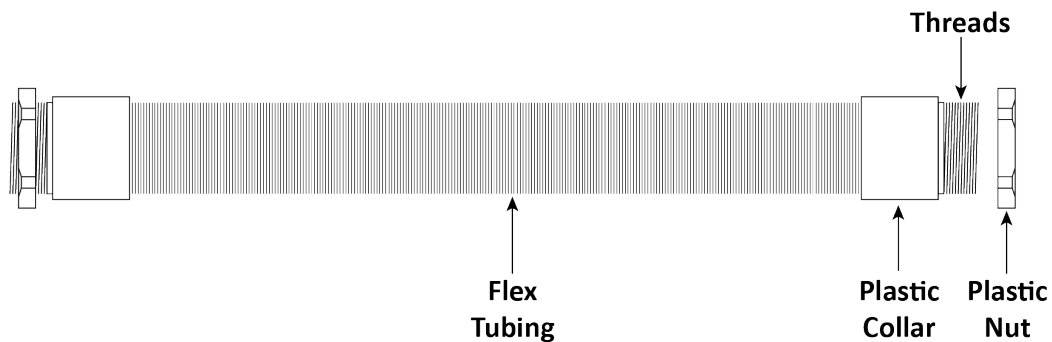

To install the Flex Tube to the Powerside Runway:

1. Unscrew the Plastic Nut from one end of the Flex Tube. It does not matter which end you use.
2. Holding the Flex Tube by the Plastic Collar, put the Threads on the end of the Flex Tube through the hole on the Powerside Runway.

The hole is about 1.5 in / 38 mm wide.

The Threads go into the hole until they are accessible from the inside, the rest of the Flex Tube stays outside.

3. On the inside of the Powerside Runway, screw the Plastic Nut back onto the Threads of the Flex Tube and tighten it.

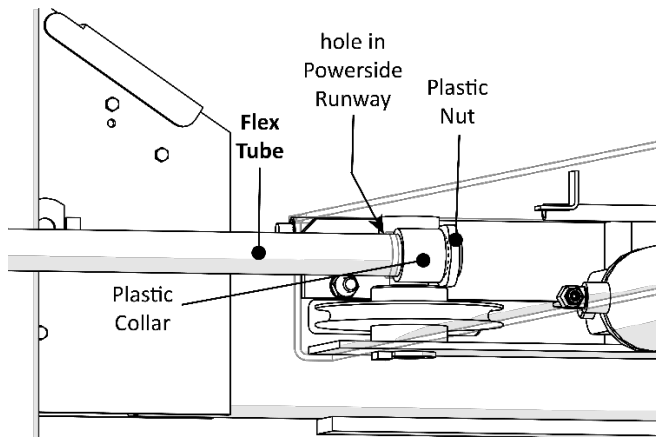

Drawing shows how to install the Flex Tube to the Powerside Runway.

View is from Rear of Powerside Runway, near the Power Post.

Not all components are shown.

4. Let the other end of the Flex Tube hang in place temporarily.

Routing the Lifting Cables

Before routing the Lifting Cables, you need to know the following:

- BendPak strongly recommends using gloves when working with the Lifting Cables.
- Each Lift has four Lifting Cables. All Lifting Cables have varying lengths and can only make one connection; if they are routed to any of the other Posts, they will either be too short or too long.
- All four Lifting Cables have a Button end and a Threaded end. The Threaded end has a label on it that identifies the Lift model the Cable is designed for (and **must** be used with), the part number (if you need to replace it), and its length (in millimeters).



- The Button end of each Lifting Cable connects at the Tie Plate on the underside of the Powerside Runway. The Button ends of each Lifting Cable stay on one side of the Tie Plate, while the rest of the Cable goes through the Tie Plate and the Retaining Plate on its way towards the appropriate Sheaves and then to the Posts to which it attaches.
- The Threaded end of each Cable goes around the appropriate Sheaves and then gets routed to a Post, where it is attached at the top.
- Before routing each Cable, remove the Nut at the Threaded end; you cannot route the Cable around the Sheaves if the Nut is still on.

- There are two kinds of Sheaves: Cable Sheaves and Gusset Sheaves. There are four Cable Sheaves at the front of the Powerside Runway and two at the Rear, for a total of six Cable Sheaves for the Lift. There are four Gusset Sheaves, one per Crosstube Gusset.
- Cable Sheaves come installed but must be removed prior to putting the Runways in place. They are put into place as you route each Cable.
- All Cables come installed. They should have been removed earlier in the installation prior to installing the Runways.
- A Lifting Cable and its corresponding Cable Sheave (or Sheaves) are put into place one at a time, starting from the top of the Post to the Tie Plate.
- The Crosstube with Large Windows has two Double Cable Sheaves (also called twin Cable Sheaves), so the two Lifting Cables that share are routed around the same time.
- Each Crosstube Gusset has a Cable Lock Pin underneath the Gusset Sheave. Each Cable Lock Pin needs to be removed when routing the Cable to its Post. Reinstall the Cable Lock Pin once the Cable is in place.
- The Cable Lock Pin prevents the Cable from coming out later; there is not enough space between the bottom of the Gusset Sheave and the Cable Lock Pin for the Cable to slip out.
- In the following drawings, the Cables and Cable Sheaves are labeled A, B, C, and D. These letters are **not** on the label on the Threaded end. You must match the Cable letter with the length.
- The four Cables for the **HD-9SW** are:
 - A: 2,983** mm / 118 inches
 - B: 6,903** mm / 271 inches
 - C: 7,123** mm / 281 inches
 - D: 11,043** mm / 434 inches
- The four Cables for the **HD-9SW-E** are:
 - A: 3,313** mm / 130 inches
 - B: 7,772** mm / 306 inches
 - C: 7,450** mm / 293 inches
 - D: 11,934** mm / 470 inches
- The four Cables for the **HD-9SWX** are:
 - A: 3,290** mm / 130 inches
 - B: 7,201** mm / 282 inches
 - C: 8,031** mm / 317 inches
 - D: 11,957** mm / 469 inches

Important: Make sure to use the correct Cable for each routing. If you put a Cable in the wrong place, it will be too short or too long. Remember that the length of each Cable is printed on the label on the Threaded end.

Before routing the Cables, extend the Piston on the Hydraulic Cylinder.

To extend the Piston:

1. Remove the Shipping Plug from the Return Line Connector.

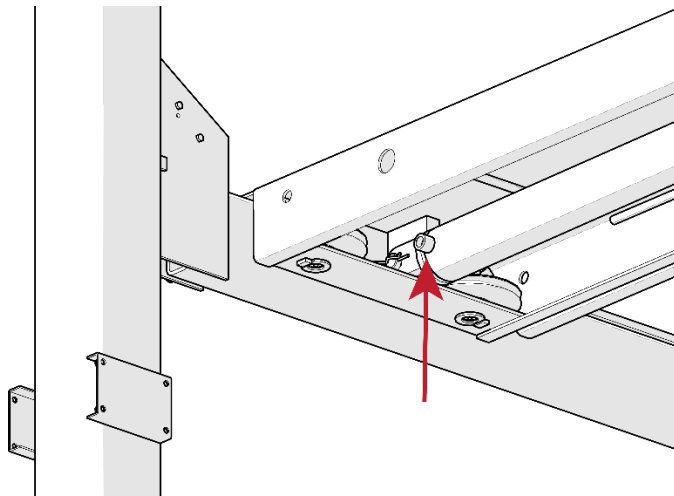

View is underneath the Powerside Runway, near the Cylinder end.

The Return Line Connector is on the Cylinder end closest to where the Power Unit will be.

Not all components are shown.

2. Attach an air pressure source to the Return Line Connector.
3. Use the air pressure to extend the Hydraulic Cylinder's Piston and Retaining Plate.

Do not exceed 50 psi.

If the Cylinder does not move, stop using air pressure; instead, use a pulling device (such as a Come-Along Tool) to extend the Piston and the Retaining Plate. Be careful not to damage the Piston.

4. Reinstall the Shipping Plug to the Return Line Connector.

The drawing on the left details the routing for all four Lifting Cables.

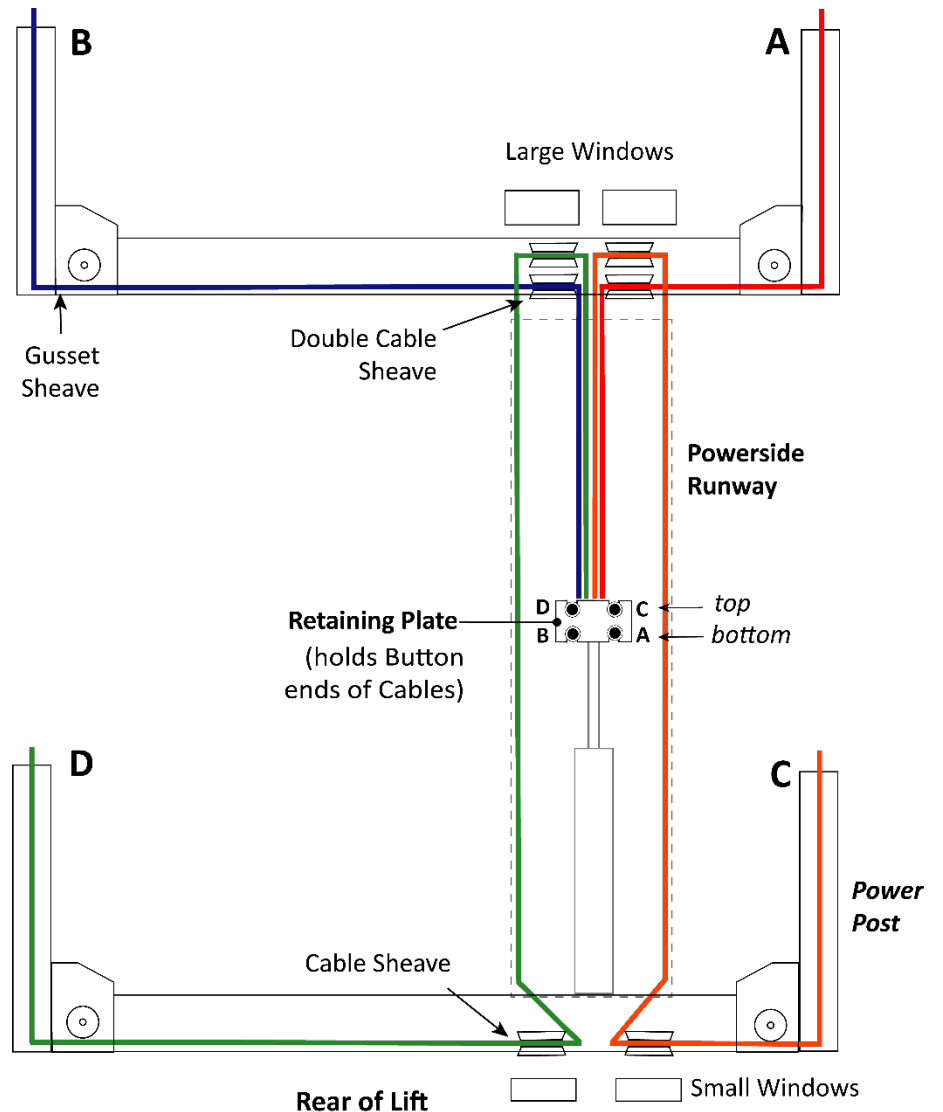

The following procedure assumes you have nearby the four Lifting Cables and Sheaves you removed **prior** to installing the Runways.

Routing Lifting Cables B and D is the same process as routing Lifting Cables A and C, just to the other two Posts and using a different set of Sheaves. Refer to the drawings in the previous section.

To route Lifting Cables A and C:

1. **Starting with Lifting Cable A**, move the entire thing to just under the Large Window it goes through, near the bottom of Post A.
Check the label to make sure you have the correct Lifting Cable.
2. Remove the Nut and Washer from the Threaded end (but keep it nearby, you will need it soon).
3. Route the Threaded end of Lifting Cable A into its Large Window on the Crosstube, push it towards Post A, and then pull the Threaded end out of the Crosstube at the bottom of the Gusset.

⚠ WARNING Use care when routing the Lifting Cables through the Crosstubes. Lifting Cables must be routed below the Mounting Bolts that secure the Crosstube to the Runways. Failure to properly route the Lifting Cables may result in serious equipment damage or injury.

4. Route the Threaded end of Lifting Cable A under where the Gusset Sheave will go when it is reinstalled, then route it up past the top of the Crosstube Gusset.

The following drawing shows how to route the Lifting Cable through the Gusset.

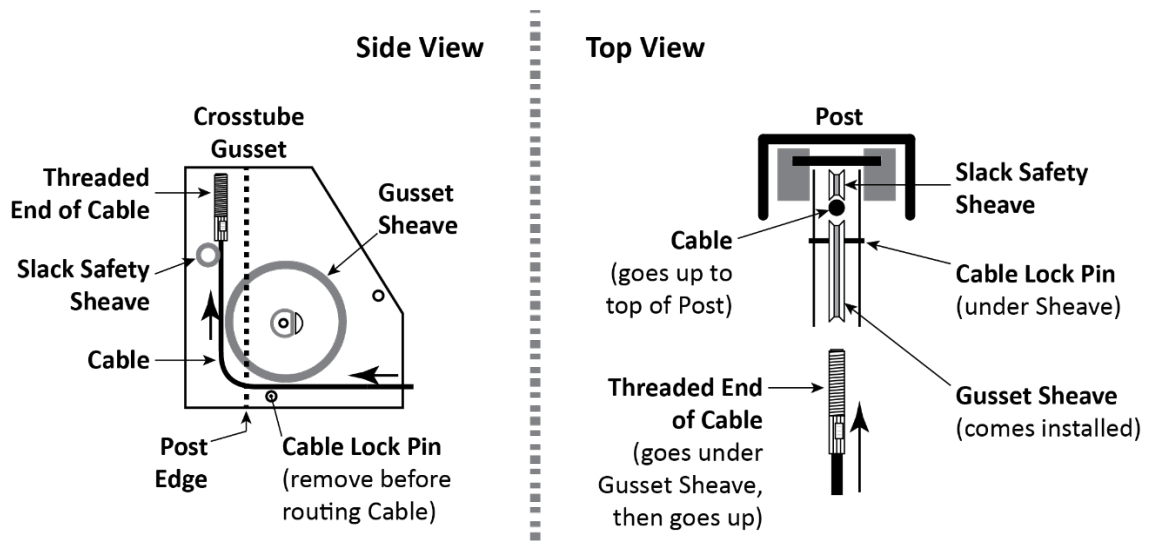

Important: When routing a Lifting Cable in its Post, the Cable must go **under** the Gusset Sheave and be on the side of the Slack Safety Sheave. When the Cables are pulled tight, the Cable prevents the Slack Safety from engaging, which is what you want. If the Cable is **not in this exact location**, the Slack Safeties will **not** work correctly.

5. With the Lifting Cable in place, reinstall the Gusset Sheave and the Cable Lock Pin in Post A.
6. Make sure Lifting Cable A is correctly positioned: in between the Gusset Sheave and the Slack Safety Sheave, with the Cable Lock Pin **under** it.
7. Push the Threaded end of Lifting Cable A up to and through the Top Cap (at the top of the Post) and **hand tighten** it in place with the Nut and Washer you removed earlier.

You only want to hand tighten the Nut at this point so that there is little play in the cabling. We will securely tighten all four Nuts later in the installation procedure.

8. **Switching to the Lifting Cable C**, repeat Steps 1 through 7 for Lifting Cable C, starting at the Small Window near the bottom of the Post C (the Power Post).
9. Reinstall a Single Cable Sheave and then make sure Lifting Cable C is correctly positioned in the Cable Sheave in the Small Window.
10. Under the Powerside Runway, move the rest of the Lifting Cable C back towards the Crosstube with Large Windows.
11. Reinstall the Double Cable Sheave in place in the Large Window, making sure Lifting Cable A is seated in the Bottom Sheave and Lifting Cable C is seated in the Top Sheave, as shown below.

The following drawing shows the Cable Sheave pairs in the Crosstube with **Large** Windows.

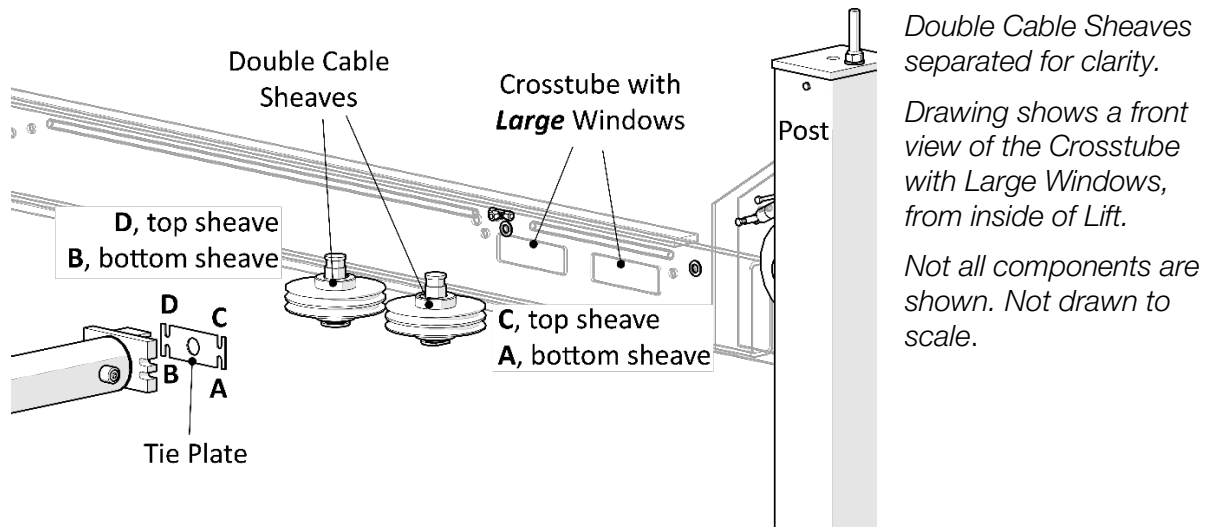

12. Loosen, but **do not** remove, the Retaining Plate (by the Hydraulic Cylinder) to give you room to slip the Button end of each Lifting Cable into place.

Do not take the Retaining Plate off, just loosen the Retaining Plate enough to give you room to slip the Button end of each Lifting Cable into place.

13. Pull the Button ends of Lifting Cables A and C back towards the middle of the Runway, past the Retaining Plate, and into its slot on the Tie Plate.

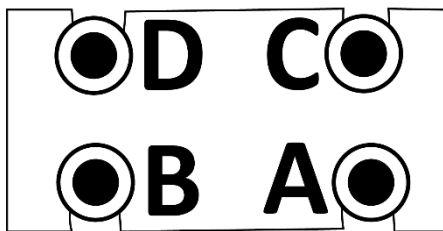

Drawing shows Tie Plate facing towards the Crosstube with Large Windows.

Not all components are shown. Not drawn to scale.

Routing Lifting Cables B and D is the same process as routing Lifting Cables A and C, just to the other two Posts and using a different set of Sheaves. Refer to the drawings in the previous section.

About Thread Sealants

We recommend using a Liquid Thread Sealant (Loctite™ 5452 or similar PTFE Thread Sealant) to seal the Hydraulic components on your Lift.

Liquid Thread Sealant lubricates and fills the gaps between the Fitting threads and leaves no residue that could contaminate the Hydraulic Fluid. Other types of Thread Sealants can shred during installation (if improperly installed) or removal and eventually enter the Hydraulic System.

Thread Sealant is not the same as *Threadlocker*, Threadlocker holds assemblies tightly in place to prevent them from loosening over time and is not easily removed.

Thread Sealant can be used with most Hydraulic Fittings, although you probably only need to use with NPT connectors.

To apply Thread Sealant:

1. Make sure the Fittings and connectors you are going to use are clean and dry.
If you are adding Thread Sealant to a Fitting or connector that has already been used with a different sealant, use a wire brush to thoroughly remove the old sealant before adding more.
2. Apply a small amount of Thread Sealant to the first four threads (skipping the top two threads) of the Fitting.

 **WARNING** Always wear the proper protective equipment when handling Thread Sealant.

You only need a small amount because the sealant spreads to the other threads as it is tightened into place.

If you put too much, the excess liquid will be pushed out when the Fitting is tightened; use a rag to wipe the excess.

3. Tighten the Fitting into the connector; do **not** over tighten the Fitting.
4. Allow a minimum of 24 hours cure time before pressurizing the system.

Working with Compression Fittings and Tubing

Your Lift comes with a roll of ¼ inch, black, polyethylene Tubing (also called Poly-Flo® Tubing) that is used with Compression Fittings in two ways: for the Return Line and for the Air Line.

Important: While both lines use Tubing and Compression Fittings, the Return Line and Air Lines are used for completely separate purposes; do not connect the two together.

Note: Compression Fittings are different from Hydraulic Fittings. This section covers Compression Fittings only.

The components involved with Compression Fittings include:

- **¼ inch, black, polyethylene Tubing.** You use a single piece of Tubing for the Return Line. The Air Lines require multiple Tubing pieces. Create the Tubing pieces for both the Return Line and the Air Lines by cutting lengths from the long roll of Tubing supplied with your Lift.
- **Elbow Compression Fittings.** The Hydraulic Cylinder uses an Elbow Compression Fitting and then one Elbow Compression Fitting goes on the Power Unit.
- **Tee Compression Fittings.** The Air Lines requires three Tee Compression Fittings.
- **Nuts, Ferrules, Rods, and Threads.** Each connector on Elbow and Tee Compression Fittings have a Nut, Ferrule, Rod, and Threads (see drawing below). The Nut holds the Tubing and Fitting together. The Ferrule compresses when you tighten the Nut on the Threads to make a secure connection. The Rod goes inside the Tubing so that nothing leaks out.

The following drawing shows the components of a connector on a Tee Compression Fitting.

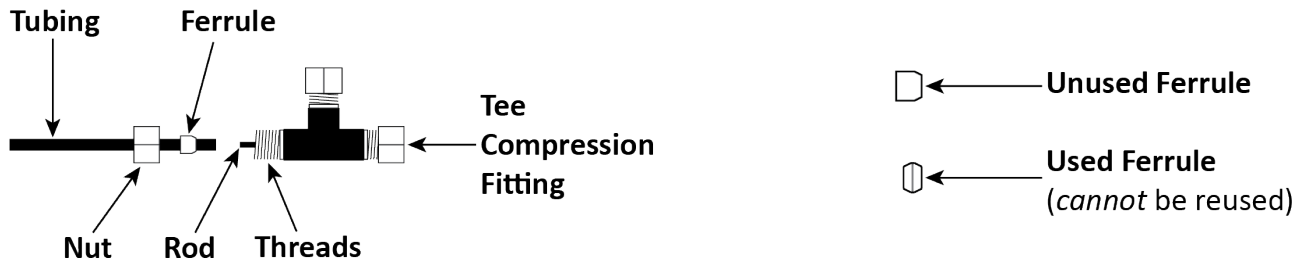

Important: *Ferrules can only be tightened once.* When you tighten the Nut on the Threads, the Ferrule gets compressed; it literally changes shape and **cannot** be used again.

To connect Tubing to a Compression Fitting:

1. Push the Tubing through the Nut and over the Rod.

Do not push hard; you only need the Tubing to go a little way over the Rod. You cannot see the Ferrule at this point, but the Tubing must go through the Ferrule and over the Rod.

2. Slide the Nut on the Tubing **away from the Fitting**, if the Nut is still on the Threads, unscrew it from the Threads and then slide it away from the Fitting. See the drawing above.
3. Slide the Ferrule over the Tubing, away from the Fitting and towards the Nut.
4. With the Nut and the Ferrule out of the way, push the Tubing further over the Rod until it stops.
5. Slide the Ferrule and the Nut back to the Threads on the Fitting.

The Ferrule goes around the Rod and under the Threads; the Nut goes onto the Threads.

6. Tighten the Nut.

Remember that the Ferrule can only be used once; do not tighten the Nut until everything is ready.

Installing the Air Lines

The Air Lines use air pressure to disengage the Safety Locks in each Post so that you can lower the Runways. **It is your responsibility to supply the air pressure (minimum of 50 PSI).**

You will need more of the ¼ inch, black, polyethylene Tubing that came with the Lift and three Air Line Tee Fittings (PN 5550395) to install the Air Lines.

⚠ CAUTION Do not let the Air Supply exceed 150 psi, the Air Lines could burst or the Safety Locks malfunction.

Important: Do not confuse the Air Lines with the Return Line. They use the same Tubing and similar-looking connectors, but they are used for completely different things; the two systems cannot be connected to each other.

The Air Line Elbow Connectors on the Crosstube Gussets come installed from the factory.

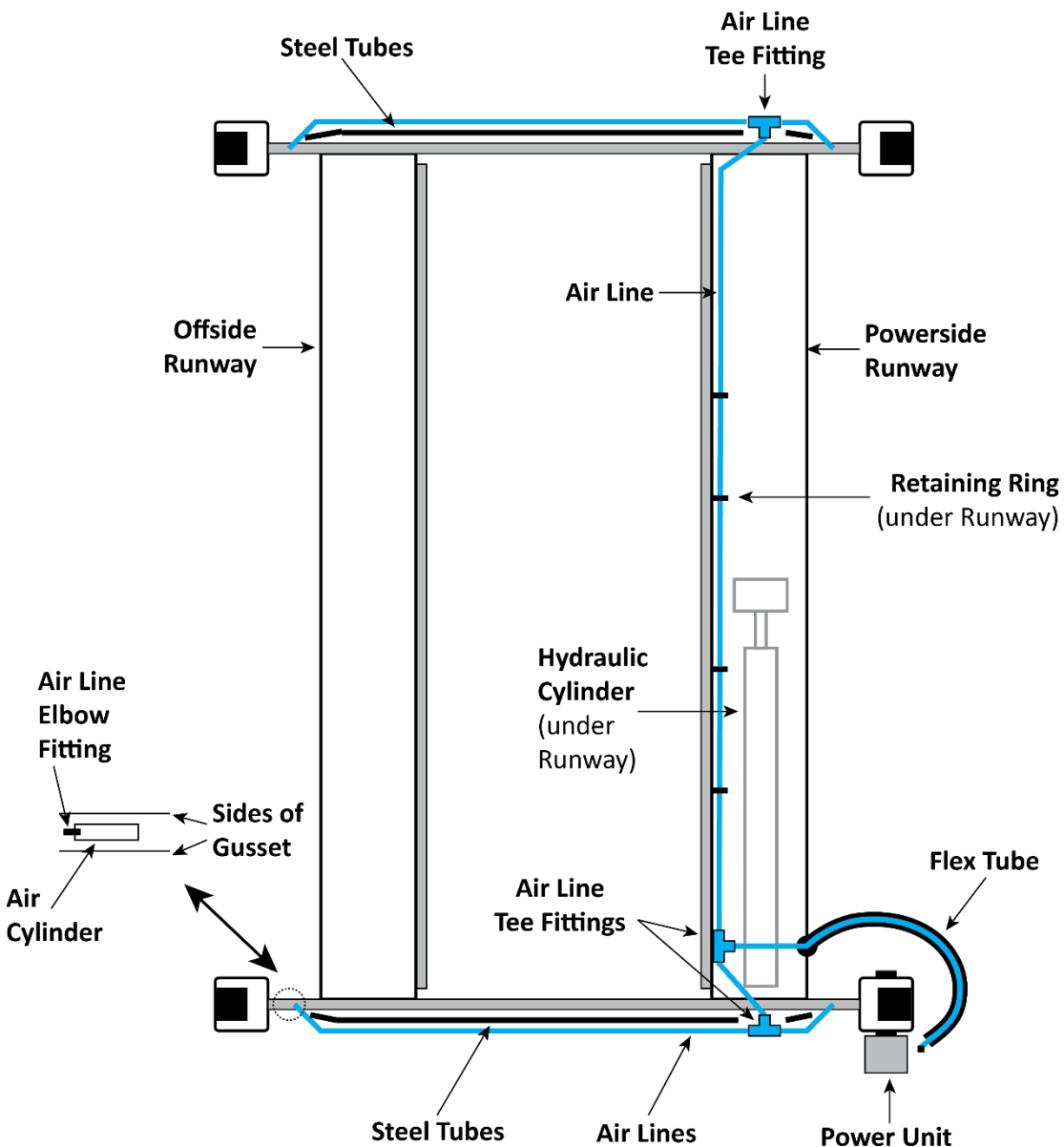

Drawing not to scale. Some components not shown. Air Lines shown outside Steel Tubes for clarity.

To install the Air Lines:

1. Find the roll of supplied ¼ inch, black, polyethylene Tubing and three Air Line Tee Fittings.
2. Measure the distances for each of the seven (7) Tubing pieces you will need (see the drawing on the previous page) for the Air Lines.
3. Cut seven pieces of Tubing to the measured lengths from the roll of Tubing.
4. Connect the various pieces of Tubing to the Air Line Tee Fittings on the Lift, as shown in the drawing on the previous page for the locations of the Tubing pieces.

Make sure to position the three Air Line Tee Connectors as shown in the drawing.

Also make sure to route the long Tubing piece that goes under the Powerside Runway through the Retaining Rings. You need to make sure the Air Lines are out of the way of where the Cables will be routed.

-  **WARNING** Make sure to route the Tubing pieces on the ***outside*** ends of the Front and Rear Crosstubes through the Steel Tubes on the ends of the Crosstubes. This keeps the Tubing and the Tee Connectors from being disturbed as you use the Lift. This is important, because if the Air Lines are disturbed, the Safety Locks on the Lift may not work correctly. If you notice that Tubing has become disconnected from an Air Line Tee Connector, take the Lift out of service, and get the Air Lines fixed.

Refer to **Working with Compression Fittings and Tubing** for more information about connecting the Tubing to the Air Line Tee Connectors.

5. Leave the Power Unit end of the Air Line hanging out of the Flex Tube opening for now. It will be connected to a Tee Fitting and the Pushbutton Air Valve later.

Installing the Return Line

The Return Line takes excess Hydraulic Fluid coming out of the Hydraulic Cylinder and sends it back into the Fluid Reservoir on the Power Unit.

The Return Line is a single piece of ¼ inch, black, polyethylene Tubing with Elbow Compression Fittings on each end.

Important: The Return Line uses the same ¼ inch, black, polyethylene Tubing as the Air Lines. Be sure not to confuse the two: the Return Line and the Air Lines do completely different things and **must** be kept separate from each other.

The following drawing shows how to connect the Return Line.

To install the Return Line:

1. Measure the distance from the Return Line Port on the Hydraulic Cylinder to the Hydraulic Return Port on the Power Unit.
2. Cut a piece of Tubing to the measured length from the roll of Tubing that comes with the Lift.
It is better to cut the Tubing a little too long rather than too short.
3. Route the Tubing from the Hydraulic Cylinder, through the Retaining Rings on the underside of the Powerside Runway, through the Flex Tube, and out next to where the Power Unit will be installed.
4. Remove the Shipping Plug from the Return Line Port on the Hydraulic Cylinder.
5. Connect and tighten the NPT end of the Elbow fitting to the Return Line Port and the COMP end connects to one end of the Return Line.

Use Liquid Thread Sealant on NPT threads only.

Refer to **Working with Compression Fittings and Tubing** for instructions.

6. Take the second Compression Elbow Fitting and connect the NPT end to the Power Unit, and the COMP end to the other end of the Return Line (coming out of the Flex Tube).

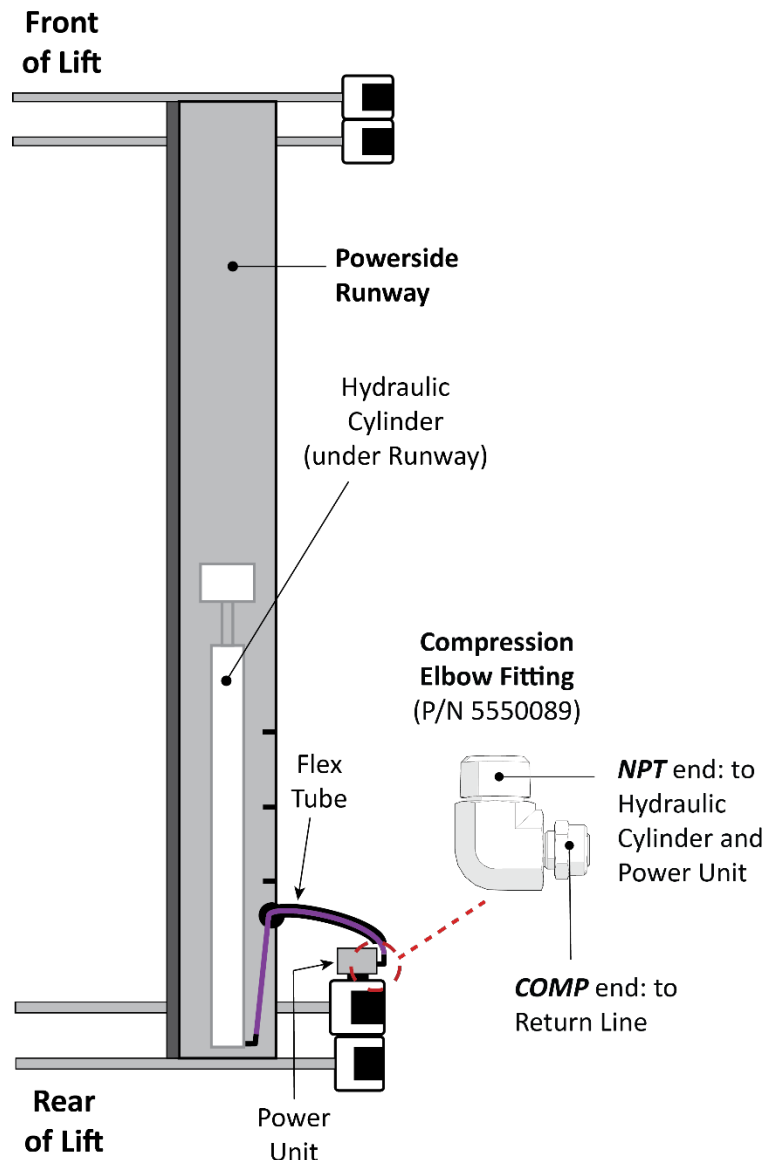

Top View of Powerside Runway. Drawing not to scale. Some components not shown or exaggerated for clarity.



IMPORTANT! PLEASE READ NOW



Hydraulic Fluid Contamination

Hydraulic Fluid Contamination poses a **serious** issue for your Lift; contaminants such as water, dirt, or other debris can get into the Hydraulic Hoses and Fittings on your Lift, making your new Lift inoperable and unusable.

Your Lift is shipped with clean components; however, BendPak strongly recommends that you take secondary precaution and clean all Hydraulic Hoses and Fittings prior to making connections. It is better and less costly to take these extra steps now so that you do not need to take your Lift out of service later to fix issues that could have been prevented at the time of the installation.

There are several ways to clean Hydraulic Hoses and Fittings:











- **Compressed air.** Use an air compressor to blow out contaminants from each Hydraulic Hose and Fitting prior to installation. Clean, dry air is preferred. Wear eye protection (safety glasses, goggles, or face shield) when using compressed air for cleaning. Never point an air hose nozzle at any part of your body or any other person.
- **Fluid flushing.** As long as the Hydraulic Fluid is clean and compatible with the system fluid, you can flush Hoses and Fittings to create turbulent flow and remove particulates. Always ensure that the fluid itself is contaminant-free.

Some additional steps that will help keep the Hydraulic Fluid clean:

- **Remove old thread seal tape.** Some ports on the Hydraulic Cylinders are shipped with temporary plugs secured with thread seal tape, so make sure to thoroughly remove any leftover thread seal tape that may inadvertently enter the Hydraulic System.
- **Use a liquid thread sealant only. Teflon paste-type thread sealant or Loctite™ 5452 thread sealant is recommended for all NPT Fittings. Do not over tighten NPT Fittings or they may crack. Do not use thread seal tape on flare-end JIC 37-degree bevel Fittings or ORB O-Ring Fittings.**
- **Always use clean equipment.** If you use a dirty bucket or funnel to transfer the Hydraulic Fluid into the Hydraulic Fluid Reservoir, the contaminants will likely be introduced into the Fluid. When using cleaning rags, use a lint-free rag.
- **Proper storage.** Keep the Hydraulic Fluid sealed in its container until ready for use. Store the Fluid in a clean, dry, and cool area.
- **Cover the Hoses and Fittings.** Before installation, do not leave the ends of the Fittings exposed; the same applies for Hydraulic Hoses. As a general rule, keep the Hydraulic Hoses and Fittings capped and kept in a clean area until ready for use.
- **Filter the new Hydraulic Fluid.** Just because it is new does not necessarily mean it is *clean*. Use an offline filtration cart or kidney loop system to make sure the Hydraulic Fluid is clean before being transferred into the Reservoir (even using a heavy-duty nylon mesh screen is better than trusting what is left at the bottom of the barrel).
- **Avoid mixing different types of Hydraulic Fluid.** If Hydraulic Fluid needs to be replaced, make sure to flush the Hydraulic System of the old Hydraulic Fluid before you add the replacement fluid; do not mix the two together.

Hydraulic System Warnings

Before applying power to the Hydraulic System note the following Warnings:

-  **WARNING** Failure to observe these warnings can result in serious personal injury including, in rare cases, death.
-  **WARNING** The Hydraulic hoses and connections **must** be inspected before any attempt to raise a Vehicle is made.
-  **WARNING** **Verify** all Hydraulic Hose connections and fittings, including unused auxiliary port plugs on the Power Unit, the Flow Divider, the Cylinders and anywhere else in the Hydraulic System are tightened.
-  **WARNING** The Power Unit is a Hydraulic Pump capable of developing pressures in excess of 5,000 psi (345 BAR). A pressure relief valve is used to set the pressure at the desired level. Tampering with, adjusting, modifying, or removing the relief valve is extremely dangerous and is not recommended. Only trained Hydraulics technicians should make adjustments to the relief valve, using calibrated hydraulic pressure gauges to assure the proper pressure setting is achieved.
-  **WARNING** Changes to the output pressure may render the power unit incompatible with pressure limitations of other components in the hydraulic circuit. This may cause catastrophic failure of those components, and could result in property damage, serious personal injury or death.
-  **WARNING** The Hydraulic System can contain high pressure which, if suddenly released, can cause serious injury or death.
-  **WARNING** Do **not** attempt to connect or disconnect Hydraulic Hoses while the equipment is loaded or while a Vehicle is on the Lift or the Hydraulic System is under pressure.
-  **WARNING** Keep bare hands away from Hydraulic Fluid; always wear gloves when handling Hydraulic Fluid, Cylinders or Hydraulic Hoses.
-  **WARNING** When handling Hydraulic Fluid, always observe the safety instructions from the manufacturer.
-  **WARNING** **Always** promptly clean any Hydraulic Fluid spills. If a leak is the source of the spill, lockout the Lift to prevent use until the Hydraulic System is repaired.

Installing the Hydraulic Hose

The Hydraulic Hose moves Hydraulic Fluid from the Power Unit to the Hydraulic Cylinder.

The following drawing shows how to connect the Curved End of the Hydraulic Hose to the Hydraulic Cylinder.

To install the Hydraulic Hose:

1. Find the Hydraulic Hose and two Hydraulic Fittings.
2. Push the Hydraulic Hose through the Flex Tube with the Curved end going to the Hydraulic Cylinder and the Straight end going to the Power Unit.

Make sure to route the Hydraulic Hose through the Retaining Clips along the side of the Runway.

3. On the Hydraulic Cylinder, remove the Shipping Plug from the Port at the Piston end.
4. Attach the NPT end of the JIC x NPT Elbow Fitting to the Hydraulic Cylinder Port (where you just removed the Shipping Plug) and tighten it.

Use Liquid Thread Sealant on NPT threads only.



Tip Leave the JIC end pointing up; this will help keeping the Hydraulic Hose up and away from where the Lifting Cables will be installed.

5. Attach the Curved end of the Hydraulic Hose to the JIC end that is facing up and tighten it.
6. Locate the Hydraulic Power Port on the Power Unit you want to use and remove the Shipping Plug.

See [Connecting to a Power Source](#) for Port locations.

7. Connect the ORB end of the ORB x JIC Fitting to the Power Unit Port and the JIC end to the Straight end of the Hydraulic Hose.
8. Securely tighten all connections.

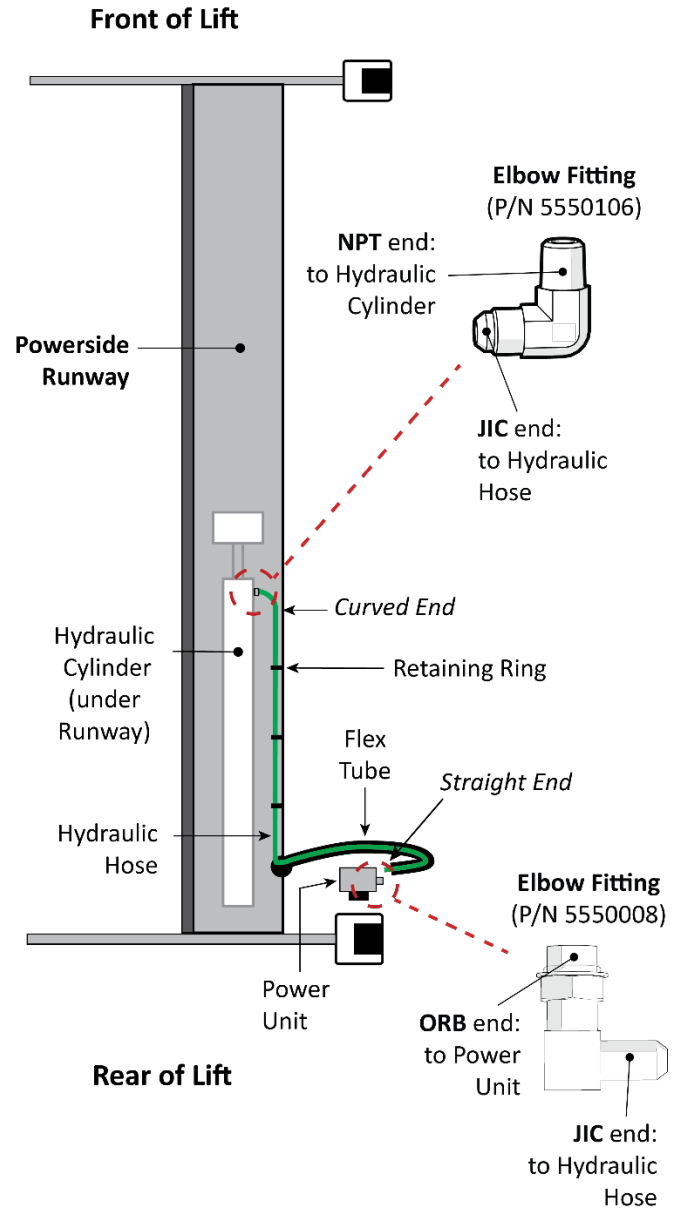

Top view of the Powerside Runway. Drawing not to scale. Some components not shown or exaggerated for clarity.

Installing the Power Unit

This section describes how to **install**, but not make the connections to, the Power Unit for your Lift. An Electrician is **not** needed to install the Power Unit; one is required to connect the Power Unit to its power source.

Important: Many people install the Flex Tube Bracket Plate and/or the Zero Angle Bracket at the same time as they install the Power Unit. Read **Installing the Flex Tube** and **Installing the Pushbutton Air Valve** (the following procedure) for more information to see if this makes sense for your installation.

⚠ DANGER Risk of explosion: The Power Unit has internal arcing or parts that may spark and should not be exposed to flammable vapors. Never expose the Power Unit motor to rain or other damp environments. Damage to the motor caused by water is **not** covered by the warranty.



Tip The Power Unit is heavy. We recommend you have one person hold the Power Unit while another person bolts it in place.

To install the Power Unit:

1. Find the Power Unit, Vibration Dampener, and supplied hardware.
2. Line up the holes on the Power Unit Back Plate and Vibration Dampener with the four holes in the Mounting Bracket you want to use.
3. Secure the Power Unit and Vibration Dampener to the Mounting Plate using four M8 x 1.25 x 25 Bolts (PN 5530010), M8 Flat Washers (PN 5545340), and M8 Nuts (PN 5535001).
4. Fill the Hydraulic Reservoir on the Power Unit with approved fluids, using care to keep the fluid clean when filling the Reservoir.

The Hydraulic Reservoir holds approximately 3.5 – 3.7 gallons (13.25 - 14 liters).

Approved fluids are any general-purpose ISO-32, ISO-46, or ISO-68 hydraulic fluid, approved automatic transmission fluids such as Dexron III, Dexron VI, Mercon V, Mercon LV, or any synthetic Multi-Vehicle automatic transmission fluid.

⚠ WARNING Do not run your Power Unit without Hydraulic Fluid; you will damage it.

Do not connect the Power Unit to a power source at this point.

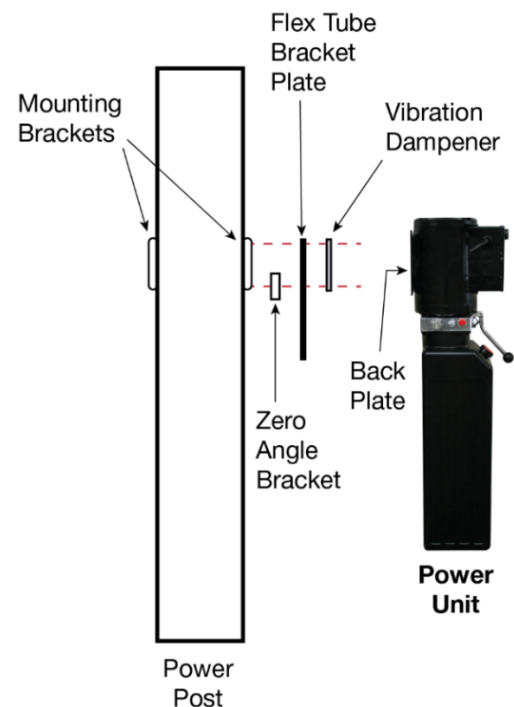

Connecting the Flex Tube Bracket Plate and Angle Plate

To connect the Flex Tube to the Power Unit, you first need to connect the Flex Tube Bracket Plate and the Flex Tube Angle Plate. That procedure is described here.

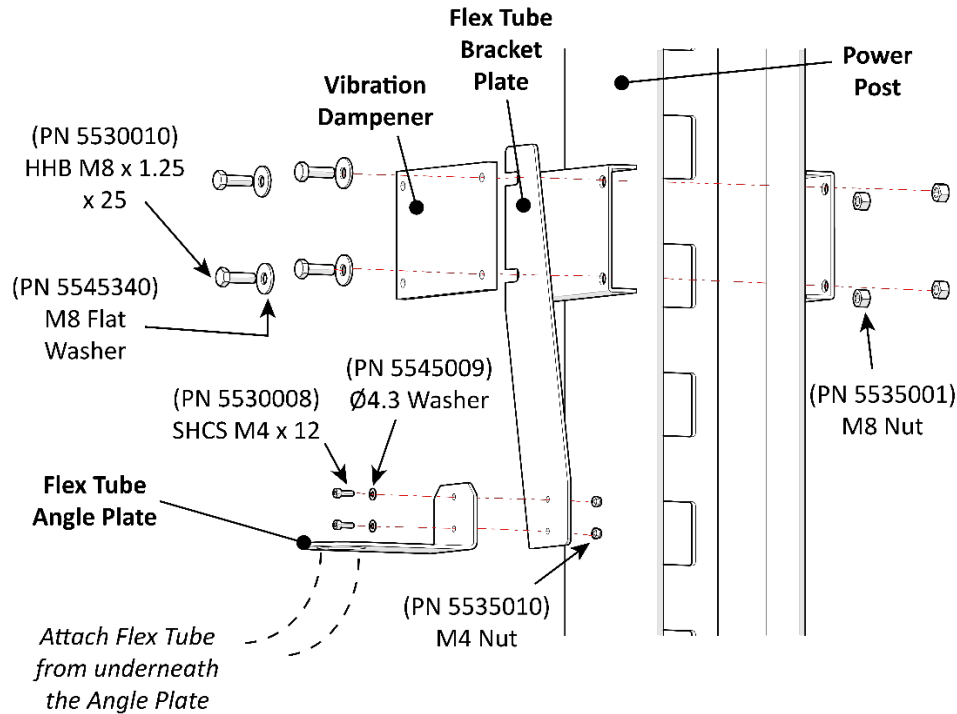

The components involved include:

- **Flex Tube Bracket Plate.** The two notches at the top attach near the Mounting Bracket on the Power Post. The two holes at the bottom connect to the Flex Tube Angle Plate.
- **Flex Tube Angle Plate.** Attaches to the Flex Tube Bracket Plate via two holes, giving you the flexibility to connect it on either side. Includes the holes to which the Flex Tubes connect.

To connect the Flex Tube Bracket and Angle Plate:

1. Find the Flex Tube Bracket Plate and the Flex Tube Angle Plate.
2. Install the Flex Tube Bracket Plate, as shown in the previous graphic.

Location options are: between the Mounting Bracket and the Back Plate or between the Back Plate and the retaining Nut.

Note: It is common to install the Flex Tube Bracket Plate between the Mounting Bracket and the Back Plate. This allows the Zero Angle Bracket (which holds the Pushbutton Air Valve and is described in the next section) to be installed between the Back Plate and the retaining Nut. This configuration is common, but not required.

3. Connect the Flex Tube Angle Plate to the Flex Tube Bracket Plate so that the holes for the Flex Tube is best positioned for connecting the Return Line, the Air Line, and the Hydraulic Hose.
4. When the Flex Tube Angle Plate is in place, unscrew the Plastic Nut from unused end of the Flex Tube.
5. Holding the Flex Tube by the Plastic Collar, put the Threads through the hole on the Flex Tube Angle Plate **from underneath**.
6. Screw the Plastic Nut back onto the Threads and tighten.

Installing the Pushbutton Air Valve

The Pushbutton Air Valve is used to lower the Runways. It can go on either side of the Power Unit, but we recommend placing it on the side facing away from the Lift to be out of the way.

The following drawing shows the Pushbutton Air Valve and its connections.

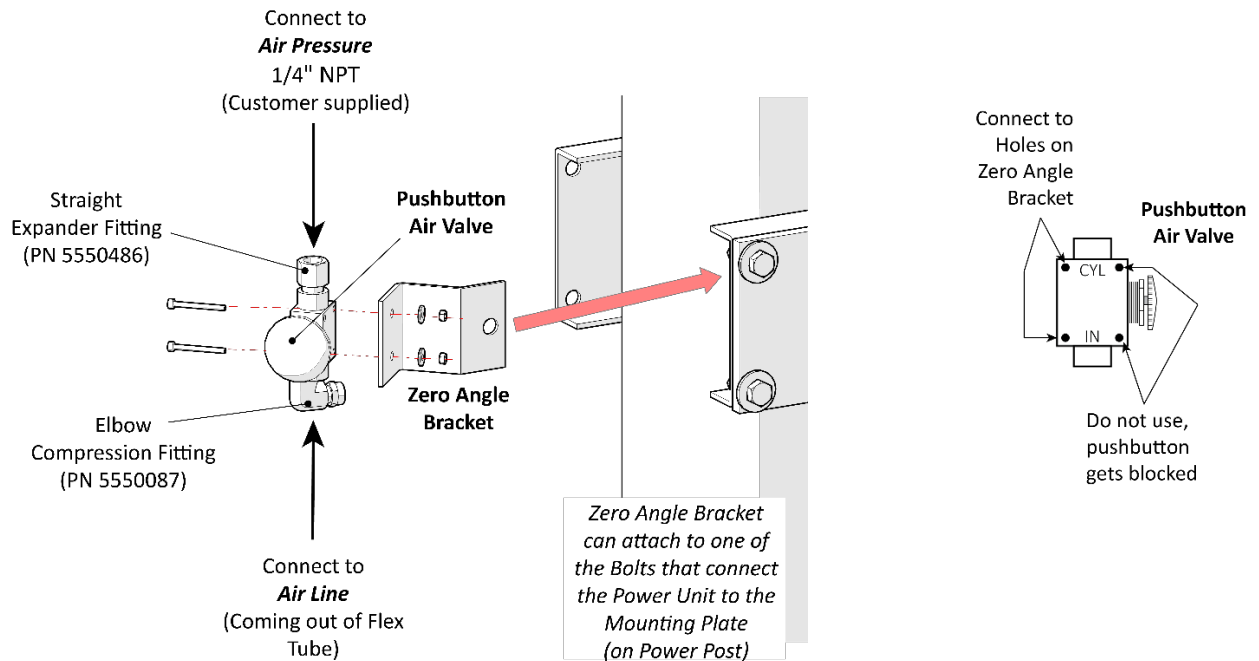

To install the Pushbutton Air Valve:

1. Find the necessary components: Zero Angle Bracket and the Pushbutton Air Valve Assembly.
2. Connect the Zero Angle Bracket at the desired location (if it has not already been connected).

The best location is one that is visible and easily reached by the Lift operator.

3. Connect the Pushbutton Air Valve to the Zero Angle Bracket.

Use the two holes on the Pushbutton Air Valve on the side away from the actual pushbutton. If you use the holes next to the pushbutton, the Zero Angle Bracket interferes with the pushbutton when you try to use it.

4. Connect the Air Line Compression Elbow Fitting and the Straight Expander Fitting to the appropriate locations on the Pushbutton Air Valve.

The Elbow Fitting connects to the opening labelled **CYL**. The Straight Fitting to the opening labelled **IN**. See the drawing above.

5. Attach the Air Line to the Compression Fitting and the customer-supplied air to the Straight Fitting.

Important: The Return Line also comes out of the Flex Tube and is the same kind of tubing as the Air Line. **Do not attach the Return Line to the Pushbutton Air Valve by mistake.** Double check to make sure you are attaching the Air Line to the Pushbutton Air Valve.

For the customer-supplied air pressure, a minimum of 50 to 150 psi / 3 to 25 cfm is required.

Connecting the Return Line

One end of the Return Line is already connected to the Hydraulic Cylinder; the other end of the Return Line needs to be connected to the Power Unit.

To attach the Return Line to the Power Unit:

1. Locate a COMP x NPT Elbow Fitting (PN 5550089) from the Parts Bag.
2. Locate the Hydraulic Return Port on the Power Unit and remove the Shipping Plug.
See [Connecting the Power Source](#) for the possible connector locations.
3. Connect and tighten the NPT end of the Elbow Fitting to the Hydraulic Return Port on the Power Unit.

Use Thread Sealant on NPT Threads only.

For information about connection compression fittings, refer to [Working with Compression Fittings and Tubing](#).

4. Find the Return Line coming out of the Flex Tube and connect it to the COMP end of the Elbow Compression Fitting.

Important: The Air Line, at one point, was also coming out of the Flex Tube and it uses the same kind of tubing as the Return Line. The Air Line should have been connected in the previous section, but if it was not, make sure you are attaching the Return Line to the Power Unit and not the Air Line. ***Do not attach the Air Line to the Power Unit by mistake.***

Connecting the Hydraulic Hose

One end of the Hydraulic Hose is already connected to the Hydraulic Cylinder; the other end of the Hydraulic Hose needs to be connected to the Power Unit.

To connect the Hydraulic Hose to the Power Unit:

1. Find the Hydraulic JIC x ORB Elbow Fitting (PN 5550008) from the Parts Bag.
2. The Hydraulic Hose should be already in place, with the Straight end coming out of the Flex Tube.
3. Locate the Hydraulic Power Port on the Power Unit and remove the Shipping Plug.
See [Connecting the Power Source](#) for the possible connector locations.
4. Connect and securely tighten the ORB end of the Elbow Fitting to the Hydraulic Power Port on the Power Unit.
5. Connect and securely tighten the JIC end of the Elbow Fitting to the Hydraulic Hose coming out of the Flex Tube.

Contacting the Electrician

As mentioned previously, there are installation tasks that **require** a certified Electrician.

⚠ DANGER All wiring **must** be performed by a licensed, certified Electrician. If someone who is not a certified Electrician attempts these tasks, they could damage the Lift or be electrocuted, resulting in serious injury or even death.

The Electrician needs to:

- **Connect a 220 VAC power source to the Power Unit.** A power source is required. Refer to **Connecting the Power Source** for more information.
- **Install a Power Disconnect Switch.** Ensures you can quickly and completely interrupt electrical power to the Lift in the event of an electrical circuit fault, emergency situation, or when equipment is undergoing service or maintenance. You must put it within sight and easy reach of the Lift operator. Refer to **Install a Power Disconnect Switch** for more information.
- **Install a Thermal Disconnect Switch.** Ensures the equipment shuts down in the event of an overload or an overheated motor. Refer to **Install a Thermal Disconnect Switch** for more information. ***The motor on the Power Unit that comes with the Lift is not thermally protected.***

The Electrician is responsible for providing:

- an appropriate plug to attach to the Power Unit
- an appropriate Power Cord that goes from the power source to the plug on the Power Unit
- a Power Disconnect Switch
- a Thermal Disconnect Switch

⚠ DANGER Risk of explosion: This equipment has internal arcing or parts that may spark and should not be exposed to flammable vapors. The Power Unit's motor should not be located in a recessed area or below floor level. Never expose the motor to rain or other damp environments; damage to the motor caused by water is **not** covered by the warranty.

Connecting the Power Source

The standard Power Unit for your Lift is 220 VAC, 60 Hz, single phase. The Power Unit must be connected to an appropriate power source.

Refer to [Wiring Diagrams](#) for wiring information.

⚠ DANGER All wiring **must** be performed by a licensed, certified Electrician. Do not perform any maintenance or installation on the Lift without first making sure that main electrical power has been disconnected from the Lift and **cannot** be re-energized until all procedures are complete. If your organization has Lockout/Tagout policies, make sure to implement them after connecting to a power source.

Important electrical information:

- Improper electrical installation can damage the motor; this is not covered under warranty.
- Use a separate circuit breaker for each Power Unit.
- Protect each circuit with a time-delay fuse or circuit breaker. For a 220 VAC, single phase circuit, use a 25 amp or greater fuse.

The following drawing shows the standard configuration for your Power Unit. **P1/P2** represents the Hydraulic Power Port. **T1/T2** or **CV1/CV2** commonly represents the Hydraulic Return Ports.

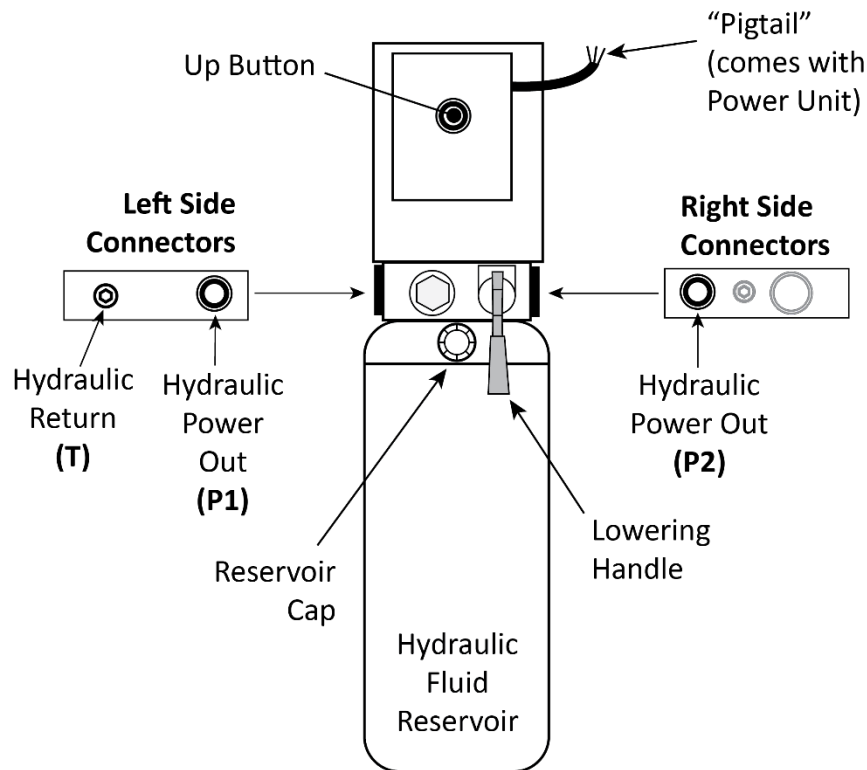

Front view of the Power Unit. Not drawn to scale. Not all components shown.

The following drawing shows the possible connector locations depending on the Power Unit you have.

Left Side Connectors

Front

Right Side Connectors

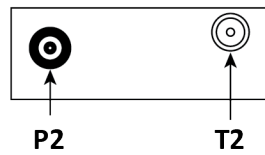
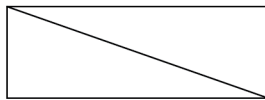
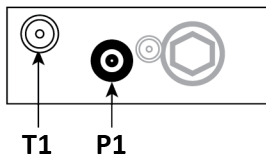
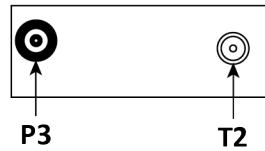
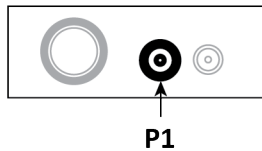
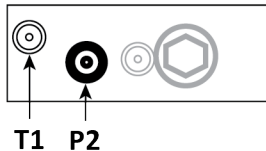
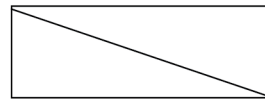
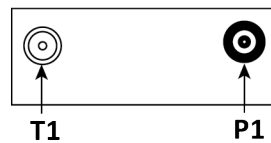

Drawing not to scale. Not all components shown.

To connect the Lift to a power source:

1. Have a certified, licensed Electrician remove the pigtail and wire from inside the Electrical Box on the Power Unit to a Power Cord and Plug or have them wire it directly into the electrical system at the Lift location.

The power cord and plug are **not** supplied with the Lift.

2. Double check to make sure the Hydraulic Fluid Reservoir has an adequate supply of fluid.

The Hydraulic Reservoir holds approximately 3.5 to 3.7 gallons. Use care to keep the fluid clean when filling the Reservoir.

Approved fluids are any general-purpose ISO-32, ISO-46, or ISO-68 hydraulic fluid, approved automatic transmission fluids such as Dexron III, Dexron VI, Mercon V, Mercon LV, or any synthetic Multi-Vehicle automatic transmission fluid.

Important: Do **not** run the Lift without adequate supply of Hydraulic Fluid; **you will damage the Power Unit.**

Installing a Power Disconnect Switch

⚠ WARNING A main Power Disconnect Switch is **not** provided with this equipment.

A Power Disconnect Switch is a National Electrical Code (NEC) requirement. They are designed to interrupt electrical power in the event of an electrical circuit fault, emergency situation, or when equipment is undergoing service or maintenance.

You are **required** to install a Power Disconnect Switch that is properly rated for the incoming power.

⚠ DANGER All wiring **must** be performed by a licensed, certified Electrician in accordance with national and local electrical codes.

Your Power Disconnect Switch must be readily accessible and installed so that it is in easy reach of the Lift operator. It must be clearly and legibly marked to indicate its purpose.

The drawing to the right shows a toggle Power Disconnect Switch between the Lift's power source and its Power Unit. A quick flip of the switch immediately cuts power to the Lift.

Make sure to have a certified Electrician install the Power Disconnect Switch.

Make sure the electrician selects a **UL-listed** Power Disconnect Switch.

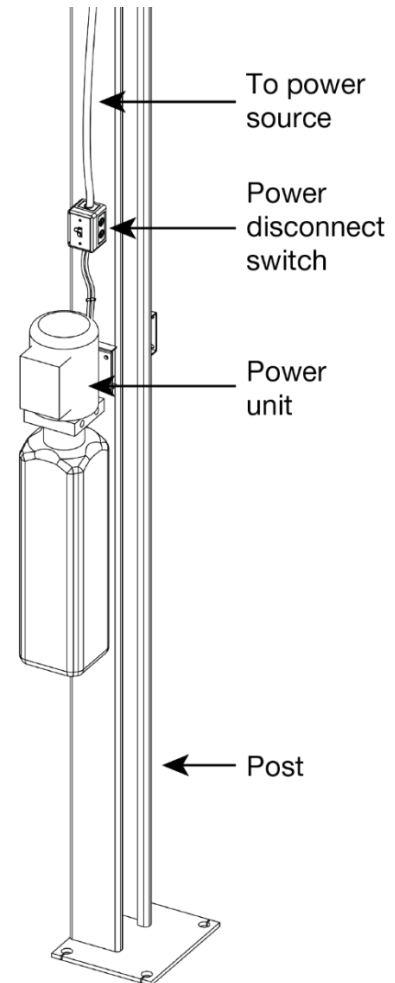

Installing a Thermal Disconnect Switch

⚠ WARNING The Lift's motor does **not** have thermal overload protection.

Connect a motor Thermal Disconnect Switch or overload device that will make sure the equipment shuts down in the event of an overload or an overheated motor.

⚠ DANGER All wiring **must** be performed by a licensed, certified Electrician.

High electrical current that exceeds the motor's full load amps (FLA) rating may result in permanent damage to the motor.

BendPak strongly recommends you **not** exceed the rated duty cycle of the Lift's motor.

Anchoring the Posts

If you have not done so already, you need to anchor the Lift's four Posts. Install one Anchor Bolt in each corner of each Base Plate, 4 per Post, 16 Anchor Bolts total.

Concrete specifications are:

- **Depth:** 4.25 inches (105 mm)
- **PSI:** 3,000 PSI, minimum
- **Cured:** 28 days, minimum

Anchor Bolt specifications are:

- **Length:** 4.75 inches (120.5 mm)
- **Diameter:** .75 inch (19 mm)
- **Anchor torque:** 85 – 95 pound feet (*do not* Torque less than 80 or more than 105)

⚠ WARNING Your Concrete and Anchor Bolts **must** meet these specifications. Only install your Lift on a Concrete surface. If you install a Lift on asphalt or any other surface, or your Concrete or Anchor Bolts do not meet these specifications, it could lead to product damage, Vehicle damage, personal injury, or even loss of life.

BendPak Lifts are supplied with installation instructions and Concrete fasteners meeting the criteria as prescribed by the current version of the American National Standard “Automotive Lifts – Safety Requirements for Construction, Testing, and Validation” ANSI/ALI ALCTV.

⚠ WARNING Use only the Anchor Bolts that came with your Lift. If you use components from a different source, you void your warranty and compromise the safety of everyone who installs or operates the Lift.

Lift buyers are responsible for conforming to all regional, structural, and seismic anchoring requirements specified by any other agencies and/or codes, such as the Uniform Building Code and/or International Building Code.

To anchor the Posts:

1. Locate the hardware you will need: four Anchor Bolts, four Nuts, and four washers **per Post**.
2. Using the Base Plates as guides, drill the holes for the Anchor Bolts—one hole in each corner of the Base Plate, so four holes total per Base Plate.

Important: Do **not** drill all the way through the concrete; if you punch completely through the slab, you compromise the holding strength of the Anchor Bolt once put into place.

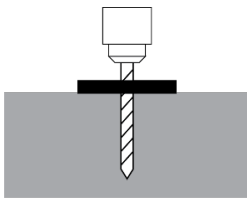

Go in straight, in the center of the hole; do not let the drill wobble.

Use a carbide bit (conforming to ANSI B212.15).

The diameter of the drill bit must be the same as the diameter of the Anchor Bolt. So if you are using a $\frac{3}{4}$ inch diameter Anchor Bolt, for example, use a $\frac{3}{4}$ inch diameter drill bit.

3. Vacuum each hole clean.

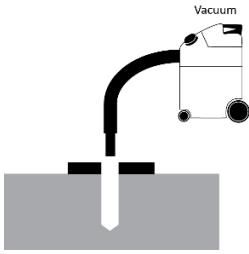

BendPak recommends using a vacuum to clean the hole. You can also use a wire brush, hand pump, or compressed air; just **make sure to thoroughly clean each hole**.

Do **not** ream the hole. Do **not** make the hole any wider than the drill bit made it.

Important: The holding strength of an Anchor Bolt is partially based on the how cleanly the Expansion Sleeve presses against the Concrete. If the hole is dirty, the Expansion Sleeve does not press as cleanly. If the hole is too wide, the Expansion Sleeve does not press with as much force. Both result in less holding strength.

4. Plumb each Post; install any needed Shims.

Use a Transit Level to estimate the Shim requirements: use a target to find the difference in height between the Posts. The difference is the estimated amount of Shim thickness you will need.

Do not shim a Post more than half an inch using the provided Shims. A maximum of 2 inches is possible by ordering optional Shim Plates. Contact BendPak at **(800) 253-2363**, extension 191 to order. Please have the model and serial number of your Lift available.

Take your time while plumbing and shimming the Posts; **it is important to make the Lift level as possible**.

5. Make sure the Washer and Nut are in place, **with the top of the Nut Flush with the top of the Anchor Bolt**, then insert the Anchor Bolt into the hole.
6. Hammer or mallet the Anchor Bolt down into the hole.

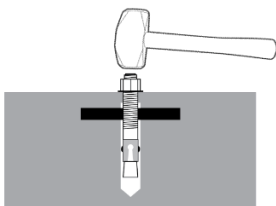

The Expansion Sleeve of the Anchor Bolt may prevent the Anchor Bolt from passing through the hole in the Base Plate too far; this is normal. The hammer or mallet will get the Expansion Sleeve through the Base Plate and into the hole.

Even using a hammer or mallet, the Anchor Bolt should only go into the hole part of the way; this is normal. If the Anchor Bolt goes **all** the way in with little or no resistance, the hole is too wide.

Once past the hole in the Base Plate, the Anchor Bolt eventually stops going down into the hole as the Expansion Sleeve contacts the sides of the hole; this is normal.

7. Hammer or mallet the Anchor Bolt the rest of the way down into the hole.

Stop when the Washer is snug against the Base Plate.

8. Wrench each Nut **clockwise** to the recommended installation torque, 85 – 95 pound feet using a Torque Wrench.

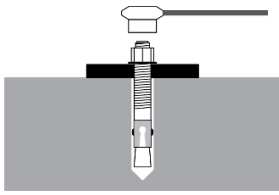

Important: Do **not** use an impact wrench to torque the Anchor Bolts.

Do **not** torque past 105 pound feet; you could damage the Concrete. Torquing the Nut forces the Wedge up, forcing out the Expansion Sleeve and pressing it tightly against the Concrete, which gives you the holding strength you need.

Final Leveling

The following procedure describes how to fine tune how level your Lift is. The goal is that the four Safety Locks engage at the same time.

To do final leveling on the Lift:

1. Raise the Runways to the first Lock position (the primary Safety Locks, not the Slack Safety Locks).
2. Use a transit level or other leveling mechanism to evaluate how level the Posts and Runways are to each other.
3. If you need to adjust a Runway, use the Top Nut and Stop Nut on the Top Cap of each Post to make adjustments to the Ladder in that Post (which impacts the levelness of the Runway and when the Safety Locks engage).

4. Raise the Runways to about mid height, listening as the Safety Locks engage.

If the Safety Locks are engaging at the same time, no further adjustments are necessary.

If the Safety Locks are not engaging at the same time, check the leveling, make necessary adjustments, and then raise the Lift again and listen as the Safety Locks engage.

5. When you are satisfied the Lift is level, firmly secure the Nuts at the top of each Post.

Installing Accessories

The accessories available for your Lift include:

- **Tire Stops.** Installed at the Front of the Lift. Hold the front Tires of the Vehicle in position.
- **Drive-up Ramps.** Installed at the Rear of the Lift. Allow Vehicles to be easily driven onto the Runways.
- **Anti-Slip Tape.** Installed on the Lift Platforms, Anti-Slip Tape is designed to increase the friction between the metal surface of the Lift and Vehicles or personnel on the Lift.
- **Gusset Covers.** Installed over the Crosstube Gusset. One cover per Gusset.

Tire Stops

Tire Stops go at the Front of the Lift. They prevent the tires of your Vehicle from going too far forward.

To install the Tire Stops:

1. Locate the two Tire Stops, Pins, and Rotor Clips needed.
2. Put one Tire Stop in position in between the Tubes on the front of the Platform, then put the Pin through the Tire Stop and the Tubes attached to the Runway.

Secure the Tire Stop with a Rotor Clip on either end of the Pin.

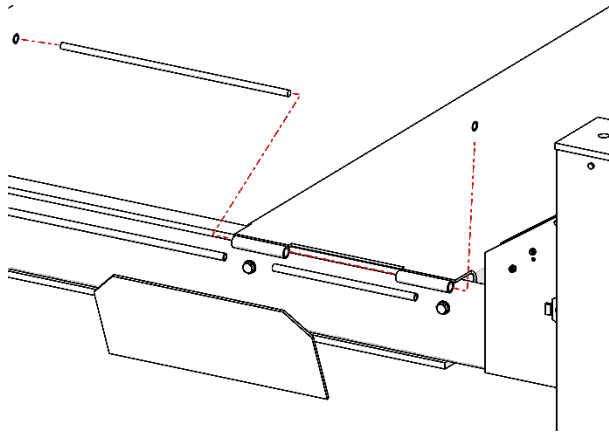

Drawing shows how to attach the Tire Stop to the front of the Runway.

Not all components are shown.

3. Repeat Steps 1 and 2 for the other Tire Stop.

Make sure to chock the Vehicle's Rear Tires when you position it in place on the Runways.

Drive-up Ramps

Use the Drive-up Ramps for Vehicles to be easily driven onto the Runways.

Note: The Ramps are heavy and awkward, so you may want to consider having two people install them; one to hold the Ramp, the other to put the components into place.

To install the Drive up Ramps:

1. Find the required components: two Ramps, two Ramp Pins, and four Rotor Clips.
2. Put a Ramp into position at the rear of the Runway, with the Ramp tube aligned between the two tubes attached to the Runway.

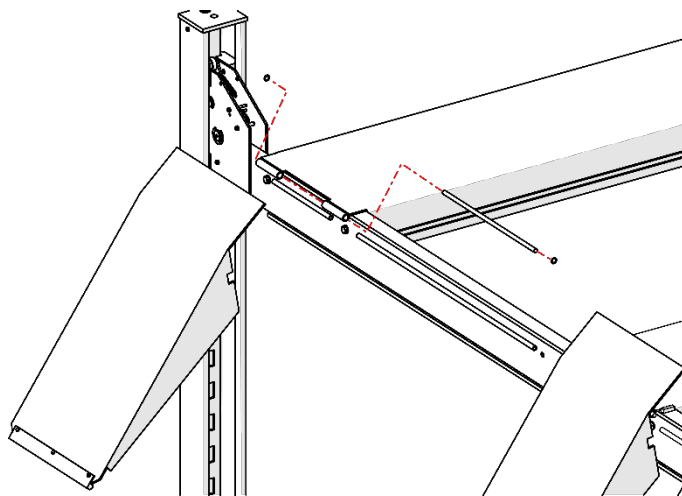

Drawings shows how to install the Drive-up Ramps at the Drive-up end of the Lift.

Attach a Rotor clip to either side of the Ramp Pin.

Not all components shown.

3. Slide a Ramp Pin through the three tubes, then put two Rotor Clips on both ends of the Ramp Pin.
4. Repeat Steps 2 and 3 for the other Ramp.

Anti-Slip Tape

Anti-Slip Tape is designed to increase the friction between the metal surface of the Lift and Vehicles or personnel on the Lift.

The Anti-Slip Tape is constructed of a #20 Grit abrasive surface with a solvent acrylic adhesive backing.

The Anti-Slip Tape (SKU 5930195) is provided in two rolls measuring 6 in. x 24 ft. (152 mm x 7.3 m) each. BendPak suggests cutting the Tape into four equal lengths 72 in (1,829 mm) long each.

IMPORTANT! Surface preparation is important. If the runway is in poor condition with gouges, holes or jagged edges, oil, grease the Anti-Slip Tape will not adhere. Lift Runways must be clean, dry, and smooth.

To apply the Anti-Slip Tape:

1. Clean the runway. Use a broom or brush to remove loose dirt and debris from the runway.
2. Thoroughly wash, rinse and dry the runway using a mild solution of soap and clean water to remove any oils, grease and water-soluble contamination. Dry the runway with a clean cloth and allow to air dry.
3. Cut the Anti-Slip Tape into four equal pieces. Suggested length is 72 in. (1,829 mm).
4. Verify the Runway is dry and clean. It is critical for maximum adhesion of the Anti-Slip Tape that the runway be dry, free of dirt, oils, and grease.
5. Measure and mark the runways with pencil guidelines to outline the tape installation area on the ramp. Refer to the figure on the next page for a suggested layout of the Anti-Slip Tape.

IMPORTANT! Do **not** install this Tape directly on the edge of a Runway. Stay at least 1 in (25 mm) away from edges. Do not attempt to bend this Tape over an edge.

6. Wash your hands. The Anti-Slip Tape's adhesive side is protected by a paper or plastic film. You will remove this film a few inches at a time to apply the Tape to the Runway.

IMPORTANT! Handle the tape by its edges. Minimize contact between the adhesive and your hands. The oils from your hands will reduce the adhesive's long-term effectiveness.

IMPORTANT! BendPak recommends two people work together to install the Tape. One person removes the backing and applies the Tape to the Runway while the second holds the Tape in place over the guidelines marked on the Runway.

7. Lay one piece of the Anti-Slip Tape on the runway and peel back about 2 inches (50 mm) of the protective film. Apply the adhesive side to the Runway inside the guidelines you created in step 5.
8. Slowly remove the film as you press the exposed Tape's adhesive side into the Runway. Work slowly and apply 2 to 5 inches at a time to stay within your guidelines.
9. After applying the Tape, use a heavy rubber roller to press the Tape into the Runway and to ensure firm contact with the adhesive.
10. Apply the Anti-Slip Tape to the remaining area of the Lift's runways, similar to the figure below.

Reference only. Do not scale drawing.

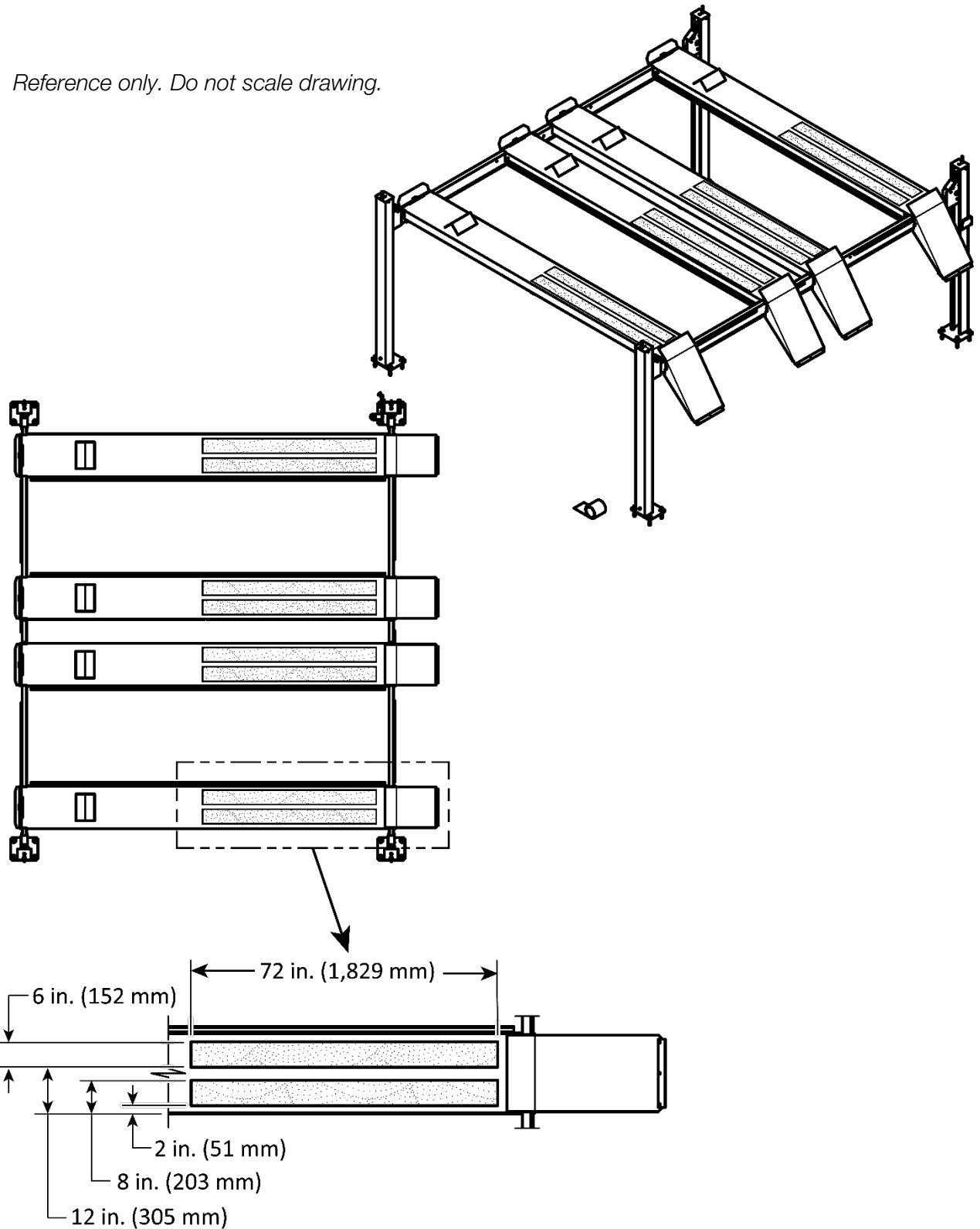

Technical support and service is available from your dealer, on the Web at bendpak.com/support, by email at support@bendpak.com, or by phone at **(800) 253-2363**, extension 196. You may also contact BendPak for parts replacement information (please have the model and serial number of your unit available) at **(800) 253-2363**, extension 191.

Gusset Covers

The Lift uses Gusset Covers to protect the Gusset components.

To install the Gusset Covers:

1. Find the four Gusset Covers from the Parts Box.
2. Attach the Cover to the top of the Crosstube Gusset; do the same for the remaining Gussets.

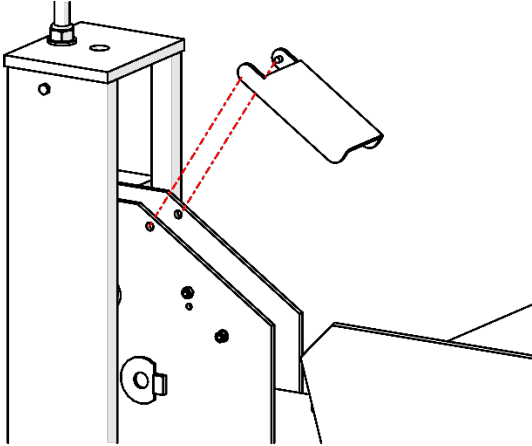

Lubricating the Lift

There are several lubrication points on the Lift; they are where Sheaves are located:

- **Inside of the Crosstube Gussets.** One on each side of the Crosstube Gusset facing the inside, for a total of eight.
- **Under the Cable Sheaves.** One under each Cable Sheave under the Powerside Runway.

Put a small amount of white lithium grease or similar on each lubrication point before you use the Lift and monthly after putting the Lift into service.

The following graphic shows the lubrication points on the Lift.

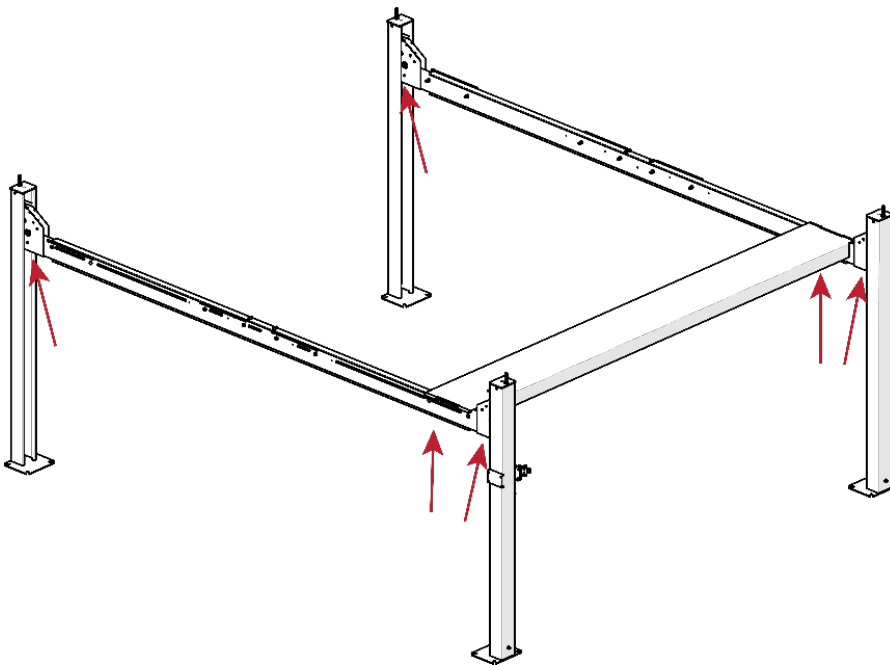

Bleeding the Hydraulic Cylinder

The Hydraulic Cylinders on the Lift are self-bleeding, which means that in most cases any air in the system can be removed by raising and lowering the Runways a few times; “bleeding” the Hydraulic System of the unwanted air.

⚠ WARNING Before performing any maintenance on your Lift (for example, bleeding the Hydraulic Cylinder or adding Hydraulic Fluid), make sure both Runways are fully lowered and the power source has been completely disconnected. If your organization has Lockout/Tagout policies, make sure to implement them after connecting to the power source.

Symptoms of air in the Hydraulic System include Runways moving erratically and/or making odd noises. These could be caused by other situations; refer to **Troubleshooting** for more information.

To bleed the Hydraulic System:

1. Raise and lower the Runways up to six times; ***pause for at least one minute between each cycle.***

⚠ CAUTION The Power Unit’s Motor cannot be run continuously; it is designed for regular use, but not continuous use.

2. Watch the Runways as you raise and lower them. When the Lift stops moving erratically or stops squeaking, you can stop the bleeding process.
3. Check the Hydraulic Fluid Reservoir on the Power Unit.

Bleeding the Hydraulic System may significantly lower the amount of Hydraulic Fluid in the reservoir.

4. Add additional Hydraulic Fluid if necessary; you can damage your motor by running it without enough Hydraulic Fluid in the reservoir.

If your Lift is still moving erratically or making odd noises after bleeding the Hydraulic System, refer to **Troubleshooting** for more information.

Final Checklist

Make sure these things have been done **before** putting the Lift into operation:

- Review the **Installation Checklist** to make sure all steps have been performed.
- Make sure the Power Unit is getting power from the power source.
- Check the Hydraulic Fluid Reservoir on the Power Unit; it must be full of approved Hydraulic Fluid or automatic transmission fluid. ***You can damage the motor by running it without enough fluid.***
- Check the Hydraulic System for leaks. Check for any loose Hydraulic Fittings and Auxiliary Port Plugs. Inspect for pinched or damaged Hydraulic Hoses and replace them before operation.
- Make sure all four Posts are properly anchored, shimmed, level, and stable.
- Make sure all Lifting Cables are properly seated in their Sheaves.
- Make sure all Safety Locks are operating normally.
- Make sure the backup Slack Safety Locks are ***not*** engaged.

-
- Make sure a copy of the *Installation and Operation Manual* is left with the Lift. It needs to be available to anyone who operates, maintains, or troubleshoots this Lift.
 - If it has not been done already, perform an Operational Test of the Lift with a typical Vehicle.

Test the Lift

BendPak strongly recommends doing an Operational Test of your Lift with standard Vehicles on the Runways before starting normal service (a typical Vehicle is not required but is recommended).

During the Operational Test, watch the Lift and its components and check for proper installation and operation. If you run into an issue that does not go away, refer to **Troubleshooting**.

Note: Residual air in the Hydraulic Systems can cause the Lift to shake, move erratically, or squeak when you start using it; this is normal. If it happens, do not worry; it will go away as the Hydraulic System is self-bleeding. If it does not go away soon, try bleeding the Cylinder of air. If it still does not go away, refer to **Troubleshooting** for additional information.

To test your Lift:

1. Before you start using your Lift, make sure to check for people, pets, or objects that might be in the path of the Lift as you raise and lower it.
2. Drive the Vehicle onto the Platform. Try to center the Vehicle's Tires in the middle of each Runway. Put the Vehicle into park, put on the parking brake, put it in gear if it is a manual transmission, and chock the wheels.
3. Press and hold the **Up** button.
4. After the Runways pass three or four Safety Locks (you will hear them), release the **Up** button.
5. Press and hold the pushbutton on the Pushbutton Air Valve, then press and hold the Lowering Handle.

The Runways back down onto the Safety Locks they just passed.

⚠ CAUTION ***Never leave the Lift without making sure that all four Safety Locks have engaged on locking positions at the same height.*** If one of the four Safety Locks do not fully engage, the Lift will not be level and you could risk damaging any Vehicles sitting on or underneath the Platforms.

6. Press the **Up** button for a few seconds to disengage the Runways from the Safety Locks, then release the **Up** button.
7. Press and hold the pushbutton on the Pushbutton Air Valve, then press and hold the Lowering Handle.
8. When the Platform gets to the ground, release the Lowering Handle and the Safety Lock Release.
9. Wait for one minute.

⚠ CAUTION Always take a break between cycles. The Power Unit's motor is **not** constant duty; it cannot be run continuously.

10. Repeat the process, this time raising the Runways to a higher Safety Lock.
11. If the Lift is working without shaking, moving erratically, or squeaking, there is no need to repeat the procedure.

If the Lift is shaking, moving erratically, or squeaking (which is normal during the start-up period), repeat the procedure a couple more times, with at least a one-minute break between cycles.

If you continue to have issues, refer to **Troubleshooting** for assistance.

Outdoor usage

Your Lift is designed for indoor use, but if you decide to use it *outside*, here's what you should know:

- **You may void your warranty.** Damages to the Motor or rusted components on the Lift caused by outdoor elements are not covered by warranty.
- **Cover the Lift.** Use a canopy or something similar to block the Lift from the sun and any precipitation, reducing the impact from it being outside.
- **Protect the Power Unit. *Very important.*** The Power Unit has an electric motor, so if that motor gets wets, it is possible for someone to get electrocuted, a fire can start, and most certainly the motor will short circuit and stop functioning. These things are not covered by the warranty. Always keep the Power Unit and all wiring covered, clean, and dry.
- **Increase the Maintenance.** Placing your Lift outside subjects it to the outdoor elements like wind, rain, dust, sunlight, snow, and other corrosive elements; you will need to double the maintenance on your Lift to minimize the impact from it being outside. For example, if the maintenance suggests doing something weekly, then do it 2-3 times a week.
- **Increase the Replacement Parts.** Everything on the Lift breaks down faster if the Lift is outside, so be prepared to order replacement parts much sooner than with indoor Lifts.

Operation

This section describes how to operate your Lift.

Safety Considerations

Do the following every time **before** you raise a Vehicle on your Lift:

- **Check the Lift.** Walk all the way around the Lift, checking for any missing, heavily worn, or damaged parts. Do not operate the Lift if you find any issues; instead, take it out of service, then contact your dealer, email support@bendpak.com, or call **(800) 253-2363**.
- **Check the area.** Keep the area around and under the Lift clean and free of obstructions; anything that could cause a problem. Do not forget to check **above** the Lift. If you find an obstruction, move it out of the way. If you find any other issues, resolve them before using the Lift. Do not allow any people or animals within 30 feet of the Lift while it is in motion.
- **Check the operators.** Make sure everyone who is going to operate the Lift has been trained in its use, has read the labels on the unit, and has read the manual. Only the operator at the Controls should be within 10 feet of the Lift when it is in motion.

Do not allow children to operate the Lift. Do not allow anyone under the influence of drugs, alcohol, or medication to operate the Lift. Do not allow any unauthorized personnel to operate the Lift.

- **Check for safety.** Make sure everyone who is going to be walking near the Lift is aware of its presence and takes appropriate safety measures. Only put vehicles on the Runways.

When raising a vehicle, do not leave it until the Platform is engaged on a Safety Lock. When lowering the Lift, do not leave it until it is on the ground.

- **Check the Vehicle.** Never exceed the Lift's weight rating. Do not allow people inside a Vehicle you are going to raise. Double check you have everything you need out of the Vehicle before raising the Lift. Make sure the Vehicle is not overbalanced on either end or either side.

Using the Controls

The Controls for the Lift include:

- **Up button.** Press and hold to raise the Runways. Located near the top of the Power Unit.

To put Runways onto a Safety Lock position. Raise the Runways a little above where you want them, then press and hold the Lowering Handle to back the Runways down onto the Safety Locks position (do not press and hold the pushbutton on the Pushbutton Air Valve). When the Runways stop going down, they are engaged on a Safety Lock.

Before leaving the Lift, make sure all four corners are engaged on their Safety Locks.

- **Lowering Handle.** Press and hold to lower the Runways. Located in the middle of the Power Unit, the Lowering Handle is long and has a ball at the end.

To lower raised Runways down to the ground. press and hold the pushbutton on the Pushbutton Air Valve first, then **press and hold** the Lowering Handle.

Watch the Runways as they go down to make sure they are coming down evenly. If they are not, stop lowering the Lift and troubleshoot the problem.

 **WARNING** Only leave your Platforms either engaged on a Safety Lock position or fully lowered.

-
- **Pushbutton Air Valve.** Press and hold the pushbutton on the Pushbutton Air Valve as part of the process to lower the Runways. Located on one side or the other of the Power Unit (depending on where it was installed). Pressing and holding the pushbutton on the Pushbutton Air Valve disengages the Safety Locks, which is needed to lower the Runways.

Raising and Lowering Vehicles

Keep the following in mind when operating your Lift:

- **Be safe.** Make sure to check for people, pets, and objects that might be in the path of the Lift as you raise or lower it. If there is something in the way, stop the Lift and move it out of the way. Watch the Lift carefully as it raises and lowers.

 **DANGER** Pay careful attention when you are raising or lowering your Lift. If a person or pet gets stuck under the Lift, they could be injured or, in rare cases, killed.

- **The Power Disconnect Switch exists for a reason.** We hope you never have to use it, but if something unexpected happens, use the **Power Disconnect Switch** to immediately stop the Lift from moving.
- **Get what you need out of the Vehicle before lifting it.** It is frustrating to raise a Vehicle and then realize you left something inside. ***Never raise your Lift with people in the Vehicle.***
- **Make sure the Vehicle is balanced.** If there is extra weight on one end or the other, remove it or balance it before raising the Vehicle.
- **Center the Vehicle's wheels on the Runway.** Centered wheels keep the Vehicle balanced.

To raise a Vehicle:

1. Drive the Vehicle onto the Runways.
2. Put the Vehicle into park and put on the parking brake. If your Vehicle has a manual transmission, place the transmission in first gear.
3. Chock the tires.
4. Walk around the Lift to make sure no obstructions will interfere with the Vehicle being lifted.
5. Press and hold the **Up** button.
6. When the Runways are just past the desired locking position, release the **Up** button, then Press and hold the Lowering Handle.
7. Once downward movement stops, release the Lowering Handle.

Make sure the Runways are on a Locking position before stepping away from the Lift.

To lower a Vehicle:

1. Verify that no one except the Lift operator is within 10 feet of the Lift.
2. Press the **Up** button to disengage the Runways from the Safety Locks.
After a second or two, release the **Up** button.
3. Press and hold the Pushbutton Air Valve **and** the Lowering Handle *at the same time*.

The Runways lower.

4. Lower the Runways all the way to the ground, then release the Pushbutton Air Valve and the Lowering Handle.
5. Remove the Tire Chocks, then carefully drive the Vehicle off the Runways.

Maintenance

 **DANGER** Before performing any maintenance on your Lift, make sure it is completely disconnected from power. If your organization has Lockout/Tagout policies, make sure to implement those procedures after connecting to the power source.

To maintain your Lift:

- **Daily:** Keep the Lift clean. Wipe up any spills, clean any dirt.
- **Daily:** Make a visual inspection of all moving parts and check for damage or excessive wear. Replace any damaged or worn parts before using the Lift.

 **DANGER** Do not use the Lift if the Cables are damaged or extremely worn. If a Vehicle is raised when you notice the damage or extreme wear, very carefully lower the Vehicle to the ground. When the Lift is on the ground, take it out of service, disconnect it from power, and make arrangements to fix the damage or wear.

- **Daily:** Make sure all Safety Locks are in good operating condition. Do not use your Lift if the Safety Locks are damaged or excessively worn.
- **Monthly:** Check all labels on the Lift. Replace them if they are illegible or missing.
- **Monthly:** Grease all lubrication points on the Lift.
- **Monthly:** Check Hydraulic Fluid levels. Refill if low.
- **Monthly:** Lubricate the wire rope (Cables). Use a wire-rope lubricant such as 90-WT gear oil or ALMASOL® Wire Rope Lubricant.
- **Monthly:** Check cable connections, bolts, and pins for proper mounting and torque.
- **Every two months:** Check all Anchor Bolts to make sure they are properly torqued. If they are loose, tighten them.
- **As needed.** Take the Lift out of service and then replace the Cables if there are signs of damage or extreme wear.

 **WARNING** Do not operate your Lift if you find maintenance issues; instead, take the Lift out of service, then contact your dealer, visit bendpak.com/support, email support@bendpak.com, or call **(800) 253-2363**.

Wire Rope Inspection and Maintenance

Your Lift's Cables, which are wire rope, should be inspected regularly:

- Wire rope should be replaced when there are visible signs of damage or extreme wear. *Do not use the Lift if it has damaged or worn Cables; **take it out of service!***

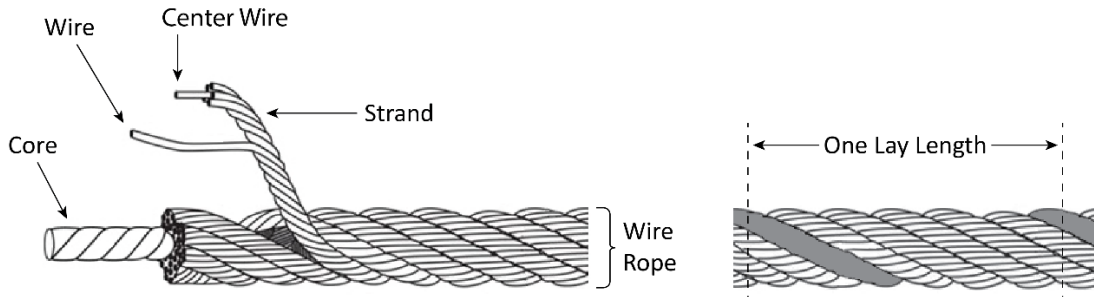

- Wire rope should be maintained in a well-lubricated condition at all times.

Wire rope is only fully protected when each wire strand is lubricated both internally and externally. Excessive wear shortens the life of wire rope. Use a wire-rope lubricant that penetrates to the core of the rope and provides long-term lubrication between each individual strand, such as 90-WT gear oil or ALMASOL® Wire Rope Lubricant. To make sure that the inner layers of the rope remain well lubricated, lubrication should be done at least every three months during normal operation.

- All Sheaves and guide rollers that contact moving wire rope should be given regular visual checks for surface wear and lubricated to make sure they run freely. This should be done every three months during normal operation.

For all sheave axles, use standard wheel bearing grease. For all Sheaves and/or guide rollers, use 90-WT gear oil or a similar heavy lubricant, applied by any method including pump/spray dispensing, brush, hand, or swabbing.

- How often should you inspect?

Wire rope should be visually inspected at least once each day when in use, as suggested by American Petroleum Institute's Recommended Practice 54 guidelines. Any wire rope that meets the criteria for removal must be immediately replaced.

- When should you replace wire rope due to broken wires?

Wire rope should be removed from service if you see six randomly distributed broken wires within any one lay length (where a single strand makes a full turn around the rope) or three broken wires in one strand within one lay length.

- Are there other reasons to replace your wire rope?

Yes. Corrosion that pits the wires and/or connectors, evidence of kinking, crushing, cutting, bird-caging, or a popped core, wear that exceeds 10% of a wire's original diameter, or heat damage.

- How do you find broken wires?

- a. Relax your rope to a stationary position and move the pick-up points off the Sheaves. Clean the surface of the rope with a cloth — a wire brush, if necessary — so you can see any breaks.
- b. Flex the rope to expose any broken wires hidden in the valleys between the strands.
- c. Visually check for any broken wires. One way to check for crown breaks is to run a cloth along the rope to check for possible snags.
- d. With an awl, probe between wires and strands and raise any wires that appear loose.

Troubleshooting

This section describes how to troubleshoot your Lift.

⚠ WARNING If your Lift is not functioning correctly, you must take it out of service until it is fixed.
All repair work must be done by qualified personnel.

Runways do not raise or do not lower, once raised.	<p>Make sure there is sufficient Hydraulic Fluid in the reservoir.</p> <p>Make sure there is no air in the Hydraulic System.</p> <p>Make sure none of the Hydraulic Hoses are pinched or leaking.</p> <p>Make sure the Power Unit is getting power.</p> <p>If the Hydraulic Fluid is dirty, replace it with clean fluid.</p> <p>Make sure Lift is not overloaded.</p>
Runways do not lower past the nearest Safety Lock even when pressing and holding the pushbutton.	Problem with the Air Lines; check to make sure all sections of the Air Line are connected and not leaking.
One corner of a Platform is lower than the other three corners.	The Safety Lock on the lower corner is not engaged. Raise the Runways up, then lower them down onto the Safety Locks. Check to make sure all four Safety Locks are engaged on Safety Locks of the same height.
Runways move erratically or squeak when in use.	Move the Runways up and down a few times to flush any residual air from the Hydraulic System. Make sure to pause for at least 2 minutes between cycles.
Runways do not stay up.	<p>Check for leaking Hydraulic Fluid.</p> <p>Make sure the Runways are left on their Safety Locks.</p>
Motor not running.	<p>Check the connection to the power source; make sure it is plugged in and of the appropriate voltage.</p> <p>Check the wiring diagram.</p>
Hydraulic Fluid is dirty.	Replace the dirty fluid with clean, approved Hydraulic Fluids, such as Dexron III, Dexron VI, Mercon V, Mercon LV, Shell Tellus S4 / S3 / S2, or comparable.
Runways make odd noises.	Lubricate the bushings on the sheaves on the sides of the Crosstubes using white lithium grease. If the Lift is new, a break-in period may be needed; run the Lift several times each day. If the noises persist, contact BendPak Support.

If you continue to have issues with your Lift, take it out of service, then contact your dealer, go to bendpak.com/support, email support@bendpak.com, or call **(800) 253-2363**.

Wiring Diagrams

5585280

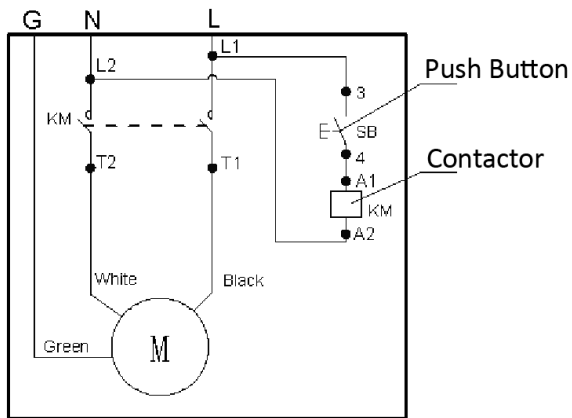

5585079

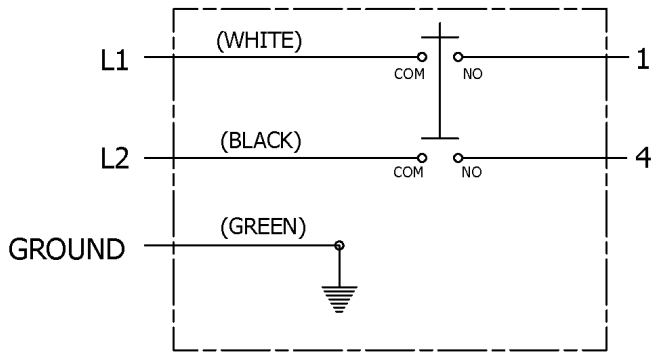

5585780

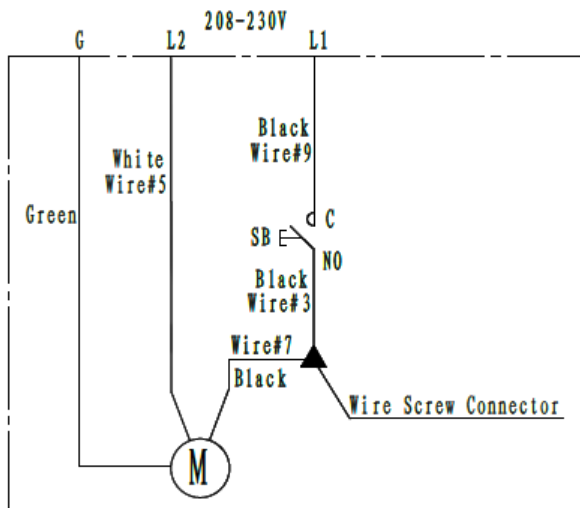

Labels



A

B

C

DANGER

VISUALLY CONFIRM THAT ALL PRIMARY SAFETY LOCKS ARE ENGAGED BEFORE ENTERING WORK AREA.

Suspension components on this lift are intended to raise and lower lift; they are NOT load-holding devices. Do not go under an elevated lift until visual confirmation is made that the lift is engaged on its Safety Locks. Refer to the manual for proper Safety Lock procedure and additional instructions.

VÉRIFIER VISUELLEMENT QUE TOUS LES VERROUS DE SÉCURITÉ PRIMAIRES SONT ENGAGÉS AVANT D'ENTRER DANS LA ZONE DE TRAVAIL.

Les composants de suspension de cet élévateur sont destinés à élever et abaisser l'ascenseur. Ce ne sont PAS des dispositifs de maintien de la charge. Ne passez pas sous un ascenseur surélevé avant d'avoir obtenu la confirmation visuelle que l'ascenseur est engagé sur ses serrures de sécurité. Reportez-vous au manuel pour connaître les procédures de verrouillage de sécurité et les instructions supplémentaires.

WARNING

Wire Rope Inspection and Maintenance

- Replace lifting cables if new or damage is evident, such as excessive broken strands, kinks, deformities, or areas of heavy strain.
- Keep wire rope in a well-lubricated condition at all times. Wire rope is only fully protected when each wire strand is lubricated, both internally and externally. Excessive wear shortens the life of wire rope. Use wire rope lubricant that penetrates to the core of the rope and provides long-term lubrication between individual strands. Lubrication should be done at least every three months during normal operation.
- All sheaves and pulley rollers in contact with the moving wire rope should be given regular visual checks for surface wear and lubricated to make sure they are free. This should be done at least every three months during normal operation. For sheave axles, use standard wheel bearing grease. For all rollers and/or pulley rollers, use 50 W² gear oil or similar heavy lubricant applied by any method including pouring, dipping, brushing, hand, and/or spraying.

Failure to read, understand, and follow these instructions may cause death or serious injury. Read and understand these instructions before using lift.

ATTENTION

Inspection et maintenance des câbles

- Remplacer les câbles de levage si l'absence de dommages sont évidents, tels que des bris excessifs des brins, des déformations ou des zones de forte abrasion excessive.
- Contrôler le câble métallique bien lubrifié en tout temps. Le câble métallique n'est entièrement protégé que lorsque chaque toron est lubrifié, à la fois à l'intérieur et à l'extérieur. Une usure excessive raccourcit la durée de vie du câble. Utilisez un lubrifiant pour câble métallique qui pénètre dans le noyau du câble et assure une lubrification à long terme entre les brins. La lubrification doit être effectuée au moins tous les trois mois en fonctionnement normal.
- Toutes les poulies et les galets en contact avec le câble métallique en mouvement doivent être inspectés et lubrifiés régulièrement de la surface et lubrifiés pour s'assurer qu'ils fonctionnent librement. Cette vérification doit être faite au moins tous les trois mois pendant le fonctionnement normal. Pour les essieux de poulies, utilisez de la graisse standard pour roulement de roue. Pour toutes les poulies et / ou les galets de roulement, utilisez de l'huile pour engrenage 50 W² ou un lubrifiant similaire, appliqué par n'importe quelle méthode, y compris la distribution par arrosage, trempage, pulvérisation, arrosage à la main, et / ou pulvérisation.

Lisez et comprenez ces instructions avant d'utiliser l'ascenseur. Ne pas lire, comprendre et suivre ces instructions peut provoquer des blessures graves, voire mortelles.

IMPORTANT OPERATION / MAINTENANCE INSTRUCTIONS - PLEASE READ

TO RAISE LIFT

- ✓ Position vehicle base at the center of each platform.
- ✓ For parking brakes or use when about behind vehicle's position.
- ✓ Release steering vehicle, use sure of personnel and/or of lift and surrounding area.
- ✓ Raise lift to desired height by pressure position on power seat.
- ✓ Maintain visual contact with vehicle and surrounding area at all times while raising lift.
- ✓ Stop immediately if you hear or observe unusual noise.
- ✓ After vehicle is raised to desired height, lower lift onto the nearest Safety Lock. Do not drive vehicle to location unnecessarily.
- ✓ Observe time-out of Primary Safety Locks are engaged before entering work area.

TO LOWER LIFT

- ✓ Make sure all personnel, tools, and equipment are clear of lift and surrounding area.
- ✓ Lower lift by raising power button or power seat. Release lift at least two inches to allow adequate clearance for truck driver.
- ✓ Press seat to lift Platform At Value.
- ✓ Lower vehicle by slow pressure and holding steering handle.
- ✓ After lowering, lift operator shall all personnel and objects are kept clear.
- ✓ Always keep a visual line of sight on lift while lowering.
- ✓ Always make sure vehicle locks are disengaged. If one of the locks has been fully engaged on descent, lift onto vehicle may cause personal injury or death.

REQUIRED MONTHLY MAINTENANCE

- ✓ Consult operator manual for factory recommended maintenance.
- ✓ Inspect lift cables to ensure lift moves fast and Safety Locks engage consistently.
- ✓ Check lift chain/cable connections, belts and pins to ensure proper mounting.
- ✓ Inspect impact sensor on lift. Do not use lift if sensor shows signs of damage or it does not work.
- ✓ Inspect all electric belts, insulation as necessary.
- ✓ Check pins for alignment and plates.
- ✓ Inspect all belts and other fasteners to make sure they are properly secured.
- ✓ Make a visual inspection of all moving parts and check for signs of excessive wear.
- ✓ Replace all faulty parts before lift is put back into operation.

<p>WARNING</p> <ul style="list-style-type: none"> • Warning: If another lifts or falls on any component of the lift is defective, do not use lift. It is not safe under these conditions. • Always operate the lift with people or equipment inside it. • Always use rated capacity. • Always use safety features as designed. Do not make any changes to make it work as you wish. • Do not use the lift unless it is engaged on Safety Locks. • Do not connect the electric motor to get over 100% damage caused by damage is not covered by the warranty. 	<p>ATTENTION</p> <ul style="list-style-type: none"> • Attention: Si une autre élève ou tombe sur un composant de l'ascenseur, ne pas utiliser l'ascenseur. Il n'est pas sûr dans ces conditions. • Ne faites jamais fonctionner l'ascenseur avec des personnes ou des équipements à l'intérieur. • Utilisez toujours la capacité nominale. • Utilisez toujours les caractéristiques de conception de l'ascenseur. Ne faites pas de modifications pour le faire fonctionner à votre guise. • Ne connectez pas l'ascenseur à un autre moteur électrique que celui qui est prévu dans le manuel de l'utilisateur. Les dommages causés par un surcoût ne sont pas garantis.
---	---

<p>CAUTION</p> <p>Lift to be used by trained operator ONLY.</p>	<p>CAUTION</p> <p>Authorized personnel only in lift area.</p>
--	--

The messages and pictographs shown are generic in nature and are meant to generally represent hazards common to all automotive lift regardless of specific style.

Funding for the development and validation of these labels was provided by the Automotive Lift Institute, P.O. Box 65, Cortland, NY 13845.

Replacement label sets may be obtained from the original lift manufacturer and ALL's member companies. They are protected by copyright. © 2018 by ALL Inc. ALLV2018

<p>WARNING</p> <p>Clear area if vehicle is in danger of falling.</p>	<p>WARNING</p> <p>Remain clear of lift when raising or lowering vehicle.</p>
---	---

<p>WARNING</p> <p>Keep clear of pinch points when lift is moving.</p>	<p>WARNING</p> <p>Keep feet clear of lift while lowering.</p>
--	--

<p>WARNING</p> <p>Do not override self-lowering lift controls.</p>	<p>WARNING</p> <p>Check wheel to prevent vehicle movement.</p>
---	---

The messages and pictographs shown are generic in nature and are meant to generally represent hazards common to all automotive lift regardless of specific style.

Funding for the development and validation of these labels was provided by the Automotive Lift Institute, P.O. Box 65, Cortland, NY 13845.

Replacement label sets may be obtained from the original lift manufacturer and ALL's member companies. They are protected by copyright. © 2018 by ALL Inc. ALLV2018

<p>NOTICE</p> <p>Read operating and safety manuals before using lift.</p>	<p>NOTICE</p> <p>Proper maintenance and inspection is necessary for safe operation.</p>
--	--

<p>NOTICE</p> <p>Do not operate a damaged lift.</p>	<p>The messages and pictographs shown are generic in nature and are meant to generally represent hazards common to all automotive lift regardless of specific style.</p> <p>Funding for the development and validation of these labels was provided by the Automotive Lift Institute, P.O. Box 65, Cortland, NY 13845.</p> <p>Replacement label sets may be obtained from the original lift manufacturer and ALL's member companies. They are protected by copyright. © 2018 by ALL Inc. ALLV2018</p>
--	---

D

⚠ DANGER

THE MAXIMUM LIFTING CAPACITY FOR THIS LIFT IS DESCRIBED BELOW

Maximum Lifting Capacity 9,000 lbs. / 4,082 kg
Max. Lifting Cap. / Front of Lift Center 4,500 lbs. / 2,041 kg
Max. Lifting Cap. / Rear of Lift Center 4,500 lbs. / 2,041 kg

Exceeding the weight capacity of this lift can damage lift and/or property and may cause personal harm, injury or death to operators and/or bystanders. All vehicles MUST be positioned on lift with CENTER OF GRAVITY midway between adapters and/or centered on runways. Damage to lift due to overloading or misuse IS NOT covered under warranty.

LA CAPACITÉ DE LEVAGE MAXIMUM POUR CE LEVAGE EST DÉCRIT CI-DESSOUS

Capacité de Levage Maximale 9,000 lbs. / 4,082 kg
Max. Capuchon De Levage. / Avant du centre de relèvement 4,500 lbs. / 2,041 kg
Max. Capuchon De Levage. / Arrière du centre de levage 4,500 lbs. / 2,041 kg

Le dépassement de la capacité de poids de cet élévateur peut endommager l'ascenseur et / ou les biens et peut causer des dommages corporels, des blessures voire la mort aux opérateurs et / ou aux passants. Tous les véhicules DOIVENT être placés sur l'élévateur avec le CENTRE DE GRAVITÉ à mi-chemin entre les adaptateurs et / ou au centre des pistes. Dommages à soulever dus à la surcharge ou une mauvaise utilisation N'EST PAS couverte par la garantie.

P/N 5900478

G

NOTICE

If attachments, accessories, or configuration modifying components used on this lift are located in the load path and affect operation of the lift, affect the lift electrical listing, or affect intended vehicle accommodation; and if they are not certified for use on this lift, then the certification of this lift shall become null and void. Contact the participant for information pertaining to certified attachments, accessories, or configuration modifying components.

www.autolift.org ©2011 by ALI, Inc. ALI / WLSIA01

H

BP BendPak Santa Paula, CA USA
www.bendpak.com

MODEL NUMBER	
DESCRIPTION	
LIFT CAPACITY	DATE OF MFG.
ROLLING JACK MAX CAP.	MAX PSI / BAR
VOLTAGE	SERIAL NUMBER
<input type="checkbox"/> 110-240V, 50-60 Hz, 1 Ph	
<input type="checkbox"/> 208-240V, 50-60 Hz, 1 Ph	
<input type="checkbox"/> 380-415V, 50-60 Hz, 3 Ph	
<input type="checkbox"/> 208-440V, 50-60 Hz, 3 Ph	
UPC	

DANGER! ERL
Disconnect Power Before Servicing

WARRANTY VOID IF DATA PLATE IS REMOVED P/N 5900592

E

⚠ ATTENTION ⚠

**MAXIMUM LIFTING CAPACITY
CAPACITÉ DE LEVAGE MAXIMUM**

**9000 Lbs.
4082 Kg.**

P/N 5900477

F

BP BendPak SANTA PAULA, CA USA
PROVIDING AUTOMOTIVE SERVICE SOLUTIONS WWW.BENDPAK.COM
PH: 530.522.212

LIFT TYPE: SURFACE MOUNT MFG. BPK SEE DATA PLATE FOR PRODUCT DETAILS
POWER: ELECTRIC/HYDRAULIC INSTALLATION - SEE OWNERS GUIDE OR CONTACT FACTORY

SAFETY INSTRUCTIONS: IF ATTACHMENTS, ACCESSORIES OR CONFIGURATION MODIFYING COMPONENTS THAT ARE LOCATED IN THE LOAD PATH, AFFECT OPERATION OF THE LIFT, AFFECT THE LIFT ELECTRICAL LISTING OR AFFECT INTENDED VEHICLE ACCOMMODATION ARE USED ON THIS LIFT AND, IF THEY ARE NOT CERTIFIED FOR USE ON THIS LIFT, THEN THE CERTIFICATION OF THIS LIFT SHALL BECOME NULL AND VOID. CONTACT THE PARTICIPANT FOR INFORMATION PERTAINING TO CERTIFIED ATTACHMENTS, ACCESSORIES OR CONFIGURATION MODIFYING COMPONENTS.

BENDPAK LIFTS ARE SUPPLIED WITH CONCRETE FASTENERS MEETING THE CRITERIA AS PRESCRIBED BY ASTM E488 - 96(2003). LIFT BUYERS ARE RESPONSIBLE FOR ANY SPECIAL REGIONAL, STRUCTURAL AND/OR SEISMIC ANCHORING REQUIREMENTS SPECIFIED BY ANY OTHER AGENCIES AND/OR CODES SUCH AS THE UNIFORM BUILDING CODE (UBC) AND/OR INTERNATIONAL BUILDING CODE (IBC).

THE MANUFACTURE, USE, SALE OR IMPORT OF THIS PRODUCT MAY BE SUBJECT TO ONE OR MORE UNITED STATES PATENTS, OR PENDING APPLICATIONS, OWNED BY BENDPAK, INC.

DO NOT REMOVE ENGINEERED BY BENDPAK INC. USA MADE IN CHINA

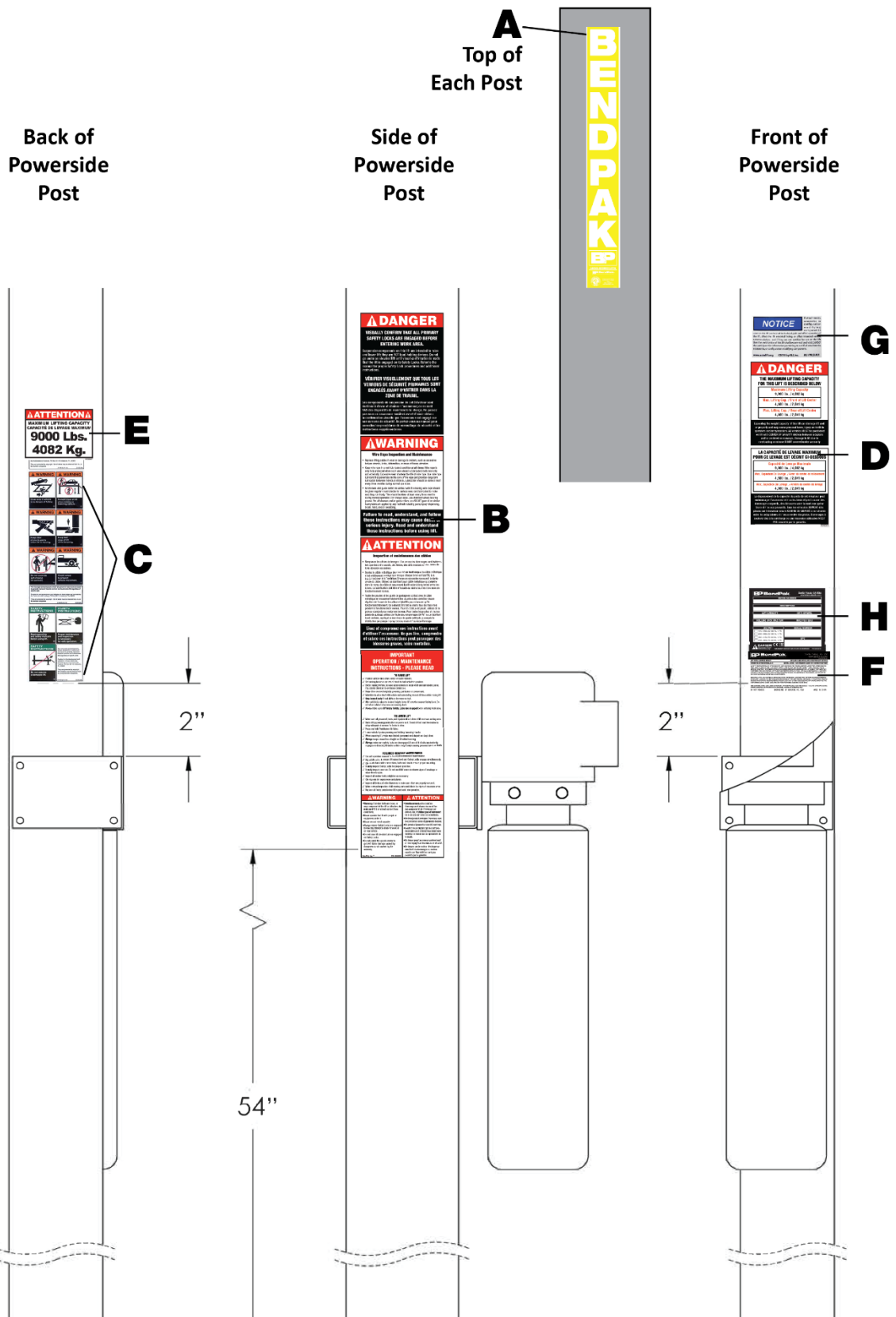

Parts Drawings

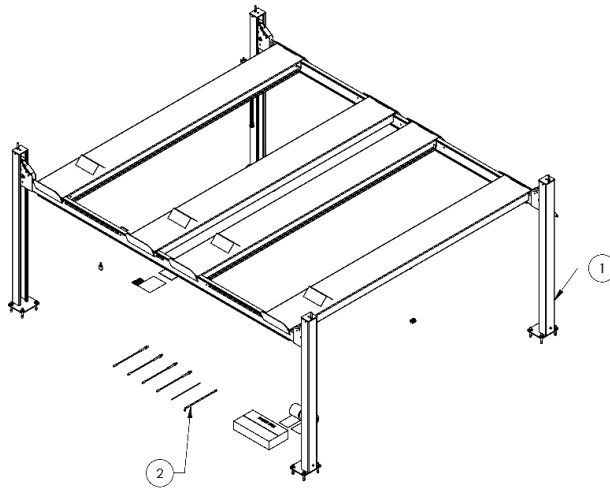

ITEM NO	PART NUMBER	DESCRIPTION	QTY	REV
1	5245078	HD-9SW LIFT SUPERSTRUCTURE	1	E
2	5250289	HD-9SW PARTS BOX	1	E

NO. 10155017 DRAWN: C.A.	DATE: 11/15/2019	BP BendPak 1645 EMONDWOOD DR. SANTA PALMA, CA 95060
CHECKED: OK	DATE: 05/14/2022	
DIMENSIONS ARE IN MM		TITLE: HD-9SW PRODUCTION LIFT VER L (CE CERT) SIZE: A DWG. NO.: 5260593 REV: J SCALE: 1:45 SHEET: 1 OF 4

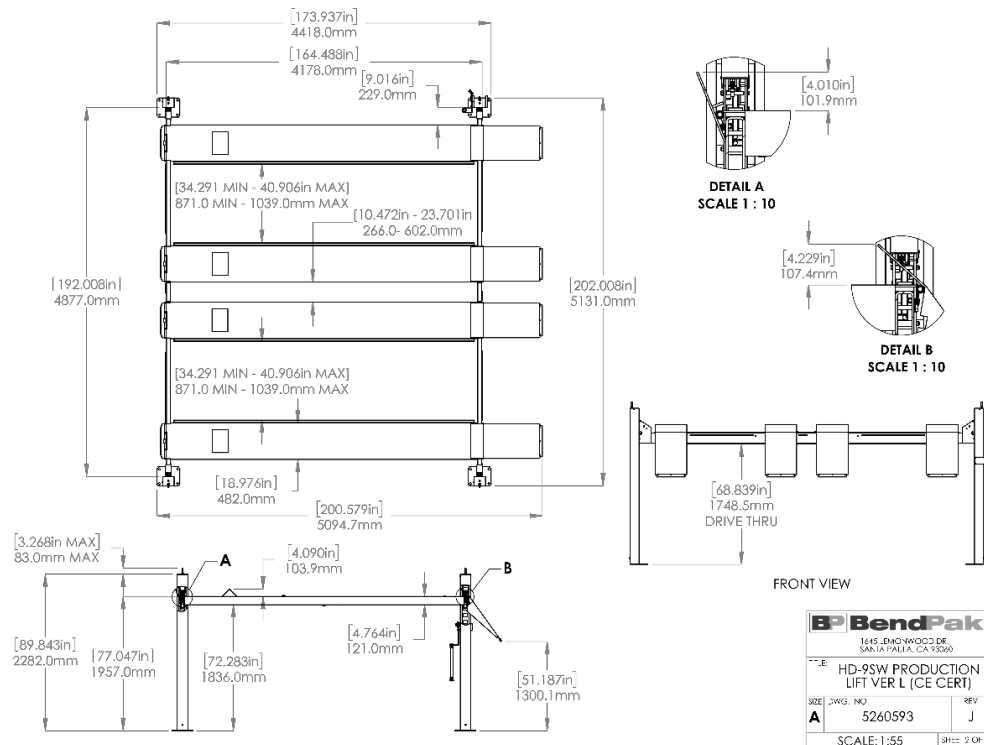

Please note, although the lift's total width dimension spanning the post baseplates is 202-inches (5,131mm) bolts located near the bottom of each post, protrude outward approximately 0.50-inch per post; or 1.0-inch (25.4mm) in total. Please be aware of this feature for installs where the lift is placed immediately next to any wall or structure

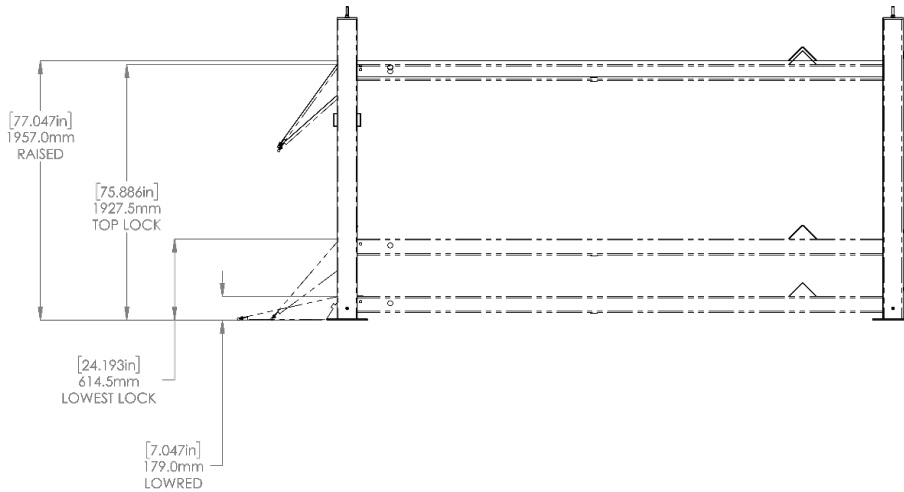

1. ALL DIMENSIONS SHOWN ARE WITH LOCK LADDER ADJUSTED ALL THE WAY UP

BendPak
 1645 LILMONWOOD DR.
 SANTA PAULA, CA 93060

TITLE: HD-9SW PRODUCTION LIFT VER L (CE CERT)

SIZE DWG. NO. 5260593 REV J

SCALE: 1:30 SHEET 3 OF 4

5175551 - PACKAGE 1				
ITEM NO	PART NUMBER	DESCRIPTION	QTY	REV
1	5216164	HD-9SW CROSSTUBE ASSEMBLY, SMALL WINDOW	1	A
2	5216163	HD-9SW CROSSTUBE ASSEMBLY, LARGE WINDOW	1	A
3	5600918	HD 9SW SAFETY LADDER WELDMENT	4	B
4	5215190	HD-9/7500BL POWER SIDE RAMP ASSEMBLY	1	AC
5	5600890	HD-7/7500/9 TIRE STOP PLATE WELDMENT	4	F
6	5600203	HD-9/7500BL OFF SIDE RAMP WELDMENT	1	H
7	5215194	HD-9SW/95WX/9AE DRIVE UP RAMP ASSEMBLY	4	H
8	5535021	NUT M16 x 2.0	4	--
9	5535008	NUT M16 x 2 NL	4	--
10	5545025	WASHER, M16 x 30mm FLAT	4	--
11	5746381	HD-7/7500/ 9 SPACER, SAFETY LADDER, 17.5mm LG	4	B
12	5535013	NUT M10 x 1.5 NL	4	--
13	5545341	WASHER M10 x Ø20 FLAT	8	--
14	5530167	HHB M10 x 1.5 x 45mm	4	--

5175550 - PACKAGE 2				
ITEM NO	PART NUMBER	DESCRIPTION	QTY	REV
1	5601138	HD-9SW POWER POST WELDMENT	1	A
2	5601137	HD-9SW POST WELDMENT	3	A
3	5600203	HD-9/7500BL OFF SIDE RAMP WELDMENT	2	H
4	5250289	HD-9SW PARTS BOX	1	E

BendPak
 1645 LILMONWOOD DR.
 SANTA PAULA, CA 93060

TITLE: HD-9SW PRODUCTION LIFT VER L (CE CERT)

SIZE DWG. NO. 5260593 REV J

SHEET 4 OF 4

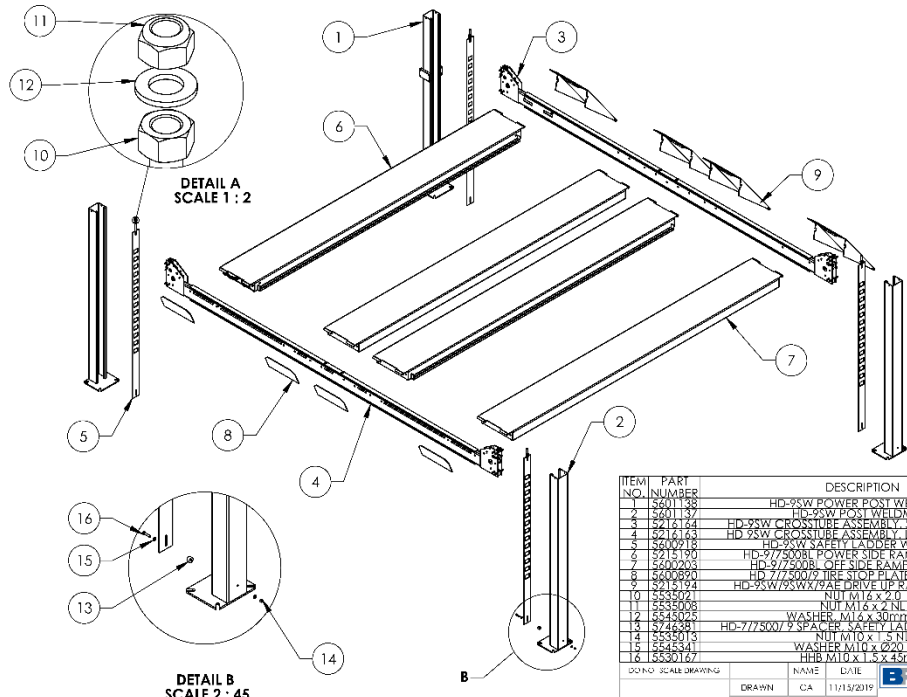

WHERE USED
HD-9SW

ITEM NO.	PART NUMBER	DESCRIPTION	QTY	REV
1	5601188	HD-9SW POWER POST WELDMENT	1	A
2	5601137	HD-9SW POST WELDMENT	3	A
3	5218164	HD-9SW CROSSRIB ASSEMBLY SMALL WINDOW	1	A
4	5218143	HD-9SW CROSSRIB ASSEMBLY LARGE WINDOW	1	A
5	5600918	HD-9SW SAFETY LADDER WELDMENT	4	B
6	5215190	HD-9/7500BL POWER SIDE RAMP ASSEMBLY	1	AC
7	5600203	HD-9/7500B OFF SIDE RAMP WELDMENT	3	H
8	5600820	HD-7/7500/9 TIE SHOE PLATE WELDMENT	4	F
9	5218124	HD-9SW/9SW/9 TIE DRIVE HP RAMP ASSEMBLY	4	H
10	5655021	NUT M16 x 2.0	4	-
11	5655006	NUT M16 x 2.0	4	-
12	5655025	WASHER M16 x 40mm FLAT	4	-
13	5218351	HD-7/7500/9 SPACER SAFETY LADDER 17.5mm LG	4	B
14	5655015	NUT M10 x 1.5 FL	4	-
15	5655341	WASHER M10 x 20.0 FLAT	8	-
16	5655017	HHB M10 x 1.5 x 45mm	4	-

DO NOT SCALE DRAWING

NAME DATE **BendPak**
DRAWN CA 11/13/2019
CHECKED

1445 LEMONWOOD DR.
SANTA PAULA, CA 93060

TITLE: HD-9SW LIFT SUPERSTRUCTURE

SIZE DWG. NO. REV
A 5245078 E

SCALE: 1:45 SHEET 1 OF 1

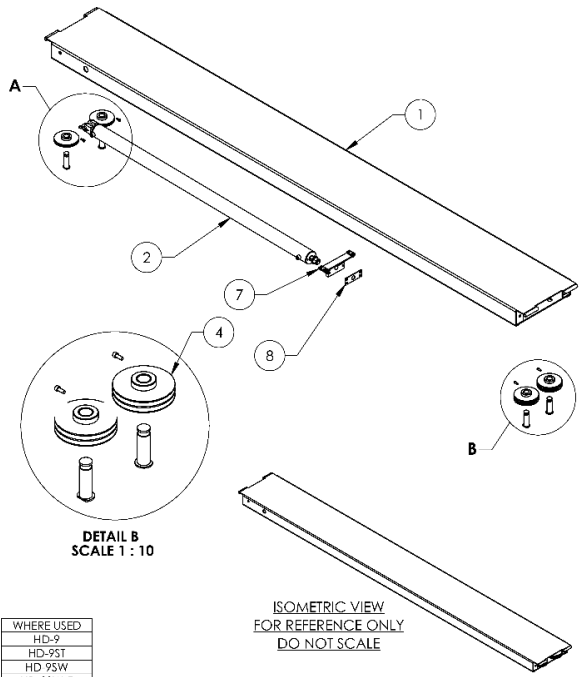

WHERE USED
HD-9
HD-9ST
HD-9SW
HD-9SW-E
HD-7500BL

ISOMETRIC VIEW
FOR REFERENCE ONLY
DO NOT SCALE

ITEM NO.	PART NUMBER	DESCRIPTION	QTY	REV
1	5600200	HD-9/7500BL POWER SIDE RAMP WELDMENT	1	G
2	5502165	CYLINDER ASSEMBLY Ø3.0 x 70	1	N
3	5215122	HD-7/7500/9 SINGLE SHEAVE ROLLER ASSEMBLY	2	E
4	5215123	HD-7500BL/9 TWIN SHEAVE ASSEMBLY	2	E
5	5600900	HD-7/7500/9 RAMP SHEAVE SHAFT WELDMENT	4	E
6	5530774	SHCS M8 x 1.25 x 20mm	4	-
7	5215820	HD-7500/9 CYLINDER FLANGE ARM ASSEMBLY	1	B
8	5731309	CABLE RETAINER PLATE	1	A

DO NOT SCALE DRAWING

NAME DATE **BendPak**
DRAWN AC 11/13/2008
CHECKED

1445 LEMONWOOD DR.
SANTA PAULA, CA 93060

TITLE: HD-9/7500BL POWER SIDE RAMP ASSEMBLY

SIZE DWG. NO. REV
A 5215190 AC

SCALE: 1:25 SHEET 1 OF 2

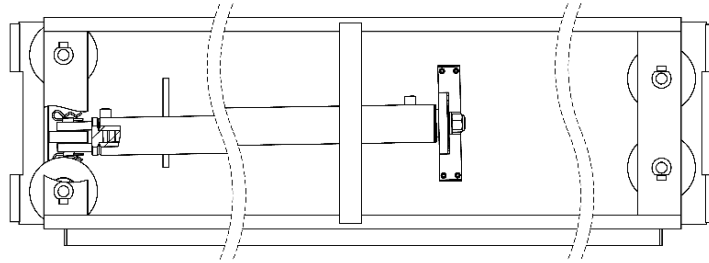
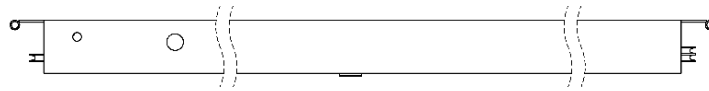

BendPak
 1645 LEMOHWOOD DR.
 SANTA FE, CA 93060

TITLE: HD-9/7500BL POWER SIDE RAMP ASSEMBLY

SUB. DWG. NO. A 5215190 REV AC

SCALE: 1:10 SHEET 2 OF 2

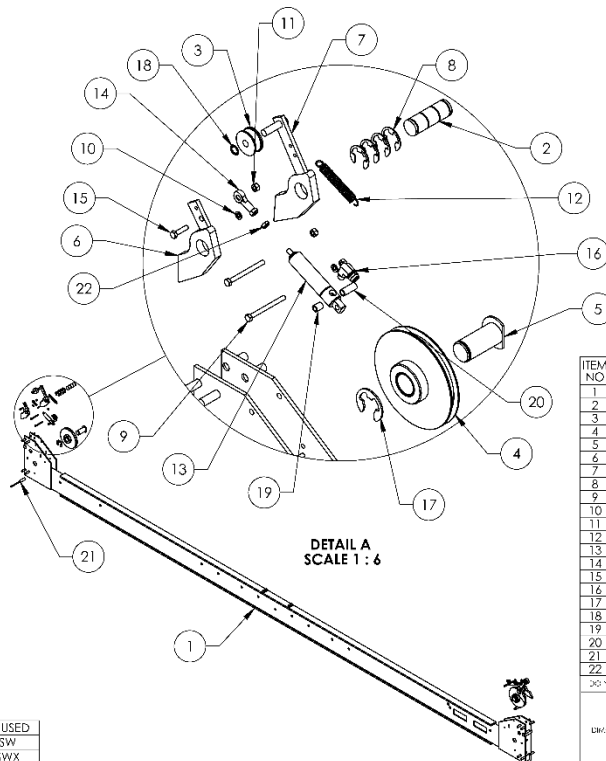

WHERE USED
 HD-9SW
 HD-9SWX

ITEM NO.	PART NUMBER	DESCRIPTION	QTY	REV
1	5601827	HD-9SW CROSSTUBE WELDMENT, LARGE WINDOW	1	A
2	5746008	D4 1/2, HD/HDS 7/7500/9/14, HDSO, 14 SAFETY PIN	2	D
3	5575420	HD 7/7500/9 SAFETY ROLLER	2	C
4	5215122	HD-7/7500/9 SINGLE SHEAVE ROLLER ASSEMBLY	2	E
5	5600160	HD-7/7500/9 CROSSTUBE SHEAVE SHAFT WELDMENT	2	G
6	5600760	D4-1/2, HD/HDS LIGHT DUTY SAFETY WELDMENT	2	C
7	5600044	4 POST LIGHT DUTY SLACK SAFETY WELDMENT	2	F
8	5540275	E RING Ø25mm OD DIN 6799 0250	8	-
9	5550005	HHB M6 x 1 x 70	6	-
10	5545005	WASHER, M6 x 12mm FLAT	4	-
11	5535357	NUT M6 x 1.0 NI	8	-
12	5540065	SPRING Ø13mm x 90mm, SLACK SAFETY	2	A
13	5505125	AIR CYLINDER, Ø19mm x 25 STROKE	2	-
14	5505625	FEMALE ROD END M6 x 33	2	-
15	5530756	HHB M6 x 1.0 x 25mm	2	-
16	5550087	FTG EL6 -04 COMP x -02 NPT	2	-
17	5540010	E RING Ø32mm OD DIN 6799	2	-
18	5505030	PUSH-ON CLIP Ø10mm SS	2	-
19	5755136	AIR CYLINDER SPACER 12mm	2	A
20	5755137	AIR CYLINDER SPACER 25mm	2	A
21	5755157	D4 1/2, HD 7/7500/9 CROSSTUBE SPACER Ø16 x Ø10 x 50	2	A
22	5535230	NUT 1/4 28 JN	2	A

DO NOT SCALE DRAWING

DRAWN: [Signature] DATE: 05/02/2022

CHECKED: [Signature]

BendPak
 1645 LEMOHWOOD DR.
 SANTA FE, CA 93060

UNBENDING IS A BENDPAK TRADE MARK

THIRD ANGLE PROJECTION

TITLE: HD-9SW CROSSTUBE ASSEMBLY, LARGE WINDOW

SUB. DWG. NO. A 5216163 REV A

SCALE: 1:30 SHEET 1 OF 1

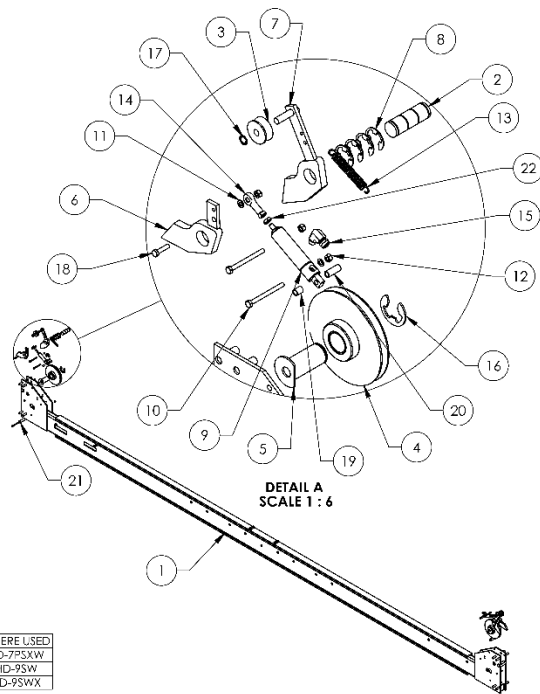

WHERE USED
 HD-775SXW
 HD-9SW
 HD-9SWX

ITEM NO	PART NUMBER	DESCRIPTION	QTY	REV
1	5601828	HD-9SW CROSSTUBE WELDMENT, SMALL WINDOW	1	A
2	5746008	D4-12, HD/HDS-777500/9/14, HD/SO-14 SAFETY PIN	2	D
3	5575420	HD-777500/9 SAFETY ROLLER	2	C
4	5215122	HD-777500/9 SINGLE SHEAVE ROLLER ASSEMBLY	2	E
5	5600160	HD-777500/9 CROSSTUBE SHEAVE SHAFT WELDMENT	2	G
6	5600760	D4-12, HD/HDS LIGHT DUTY SAFETY WELDMENT	2	C
7	5600344	4 POST LIGHT DUTY SLACK SAFETY WELDMENT	2	F
8	5540275	E RING Ø23mm OD DIN 6799 0250	8	-
9	5502195	AIR CYLINDER Ø13mm x 25 STROKE	2	-
10	5530005	HHB M6 x 1 x 70	6	-
11	5545005	WASHER, M6 x 12mm FLAT	4	-
12	5535357	NUT M6 x 1.0 NL	8	-
13	5540065	SPRING Ø13mm x 90mm, SLACK SAFETY	2	A
14	5505625	FEMALE ROD END M6 x 33	2	-
15	5550087	FTG ELB -04 COMP x -02 NPT	2	-
16	5540010	E RING Ø32mm OD DIN 6799	2	-
17	5505030	PUSH-ON CLIP Ø10mm SS	2	-
18	5530756	HHB M6 x 1.0 x 25mm	2	-
19	5755136	AIR CYLINDER SPACER, 2mm	2	A
20	5755137	AIR CYLINDER SPACER, 25mm	2	A
21	5755157	D4-12, HD-777500/9 CROSSTUBE SPACER, Ø16 x Ø10 x 50	2	A
22	5535230	NUT 1/4-28, IN	2	-

ISO 1 SCALE DRAWING

DRAWN: M 05/02/2022
 CHECKED: OR

THIRD ANGLE PROJECTION

1645 LEMO WOOD DR.
 SANTA ANA, CA 92705

BendPak

TITLE: HD-9SW CROSSTUBE ASSEMBLY, SMALL WINDOW

SIZE: DWG. NO. 5216164 REV A

SCALE: 1:30 SHEET 1 OF 1

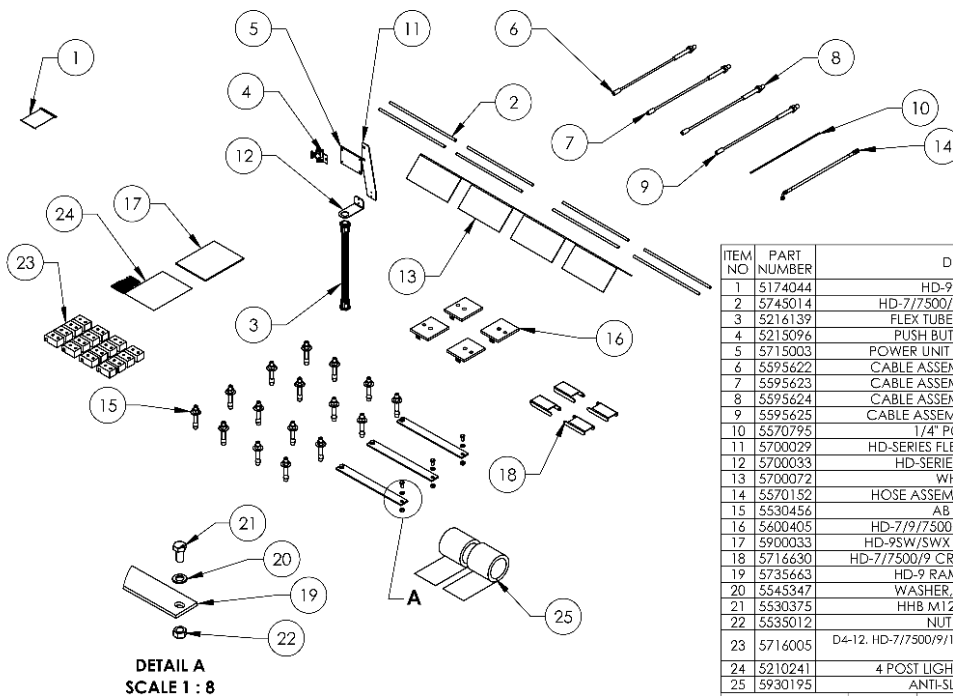

WHERE USED
 HD-9SW

ITEM NO	PART NUMBER	DESCRIPTION	QTY	REV
1	5174044	HD-9SW PARTS BAG	1	B
2	5745014	HD-777500/9 DRIVE UP RAMP PIN	8	B
3	5216139	FLEX TUBE KIT, UP TO 2000mm	1	A
4	5215096	PUSH BUTTON AIR ASSEMBLY	1	G
5	5715003	POWER UNIT VIBRATION DAMPENNER	1	B
6	5595622	CABLE ASSEMBLY Ø10 x 2983mm ST	1	B
7	5595623	CABLE ASSEMBLY Ø10 x 6903mm ST	1	B
8	5595624	CABLE ASSEMBLY Ø10 x 7123mm ST	1	B
9	5595625	CABLE ASSEMBLY Ø10 x 11043mm ST	1	B
10	5570795	1/4" POLY-FLO TUBING	21000mm*	-
11	5700029	HD-SERIES FLEX TUBE BRACKET PLATE	1	F
12	5700033	HD-SERIES FLEX TUBE ANGLE	1	E
13	5700072	WHEEL CHOCK	4	B
14	5570152	HOSE ASSEMBLY Ø6.4 x 3565mm SB	1	B
15	5530456	AB 3/4" x 4 - 3/4"	16	-
16	5600405	HD-777500/9 TOP PLATE WELDMENT	4	C
17	5900033	HD-9SW/SWX INSTALLATION MANUAL	1	-
18	5716630	HD-777500/9 CROSSTUBE COVER, PLASTIC	4	A
19	5735663	HD-9 RAMP STRAP, BOLT ON	3	B
20	5545347	WASHER, M12 x 1.75 x 25 CL12.9	6	-
21	5530375	HHB M12 x 1.75 NL	6	-
22	5535012	NUT M12 x 1.75 NL	6	-
23	5716005	D4-12, HD-777500/9/14/HDSO-14 POLYETHYLENE SLIDE BLOCK	16	M
24	5210241	4 POST LIGHT DUTY CE PARTS BAG	1	A
25	5930195	ANTI-SLIP TAPE, 6" x 2411	2	-

ISO 1 SCALE DRAWING

DRAWN: CA 11/7/2019
 CHECKED: OR 05/09/2022

THIRD ANGLE PROJECTION

1645 LEMO WOOD DR.
 SANTA ANA, CA 92705

BendPak

TITLE: HD-9SW PARTS BOX

SIZE: DWG. NO. 5250289 REV E

SCALE: 1:25 SHEET 1 OF 1

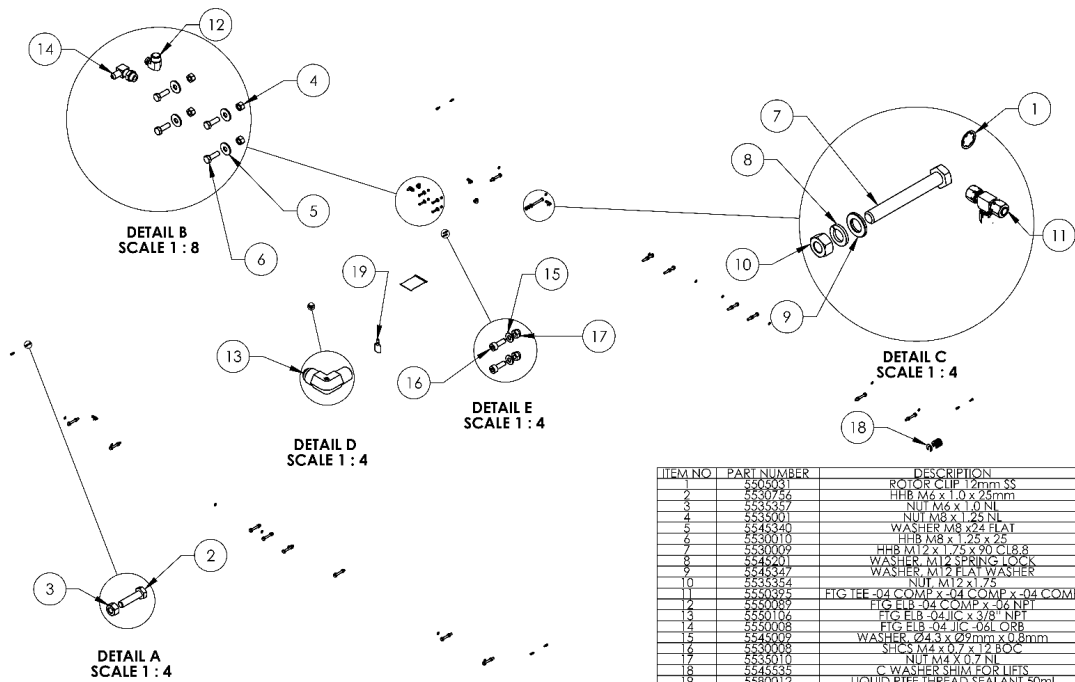

WHERE USED
HD-9SW
HD-9SW-E
HD-9SWX

ITEM NO	PART NUMBER	DESCRIPTION	QTY	REV
1	5500001	ROTOR CLIP 12mm SS	16	-
2	5530756	HHB M6 x 1.0 x 25mm	8	-
3	5530557	NUT M6 x 1.0 NL	8	-
4	5533001	NUT M8 x 1.25 NL	4	-
5	5545340	WASHER M8 x 24 FLAT	4	-
6	5530110	HHB M8 x 1.25 x 26	4	-
7	5530009	HHB M12 x 1.75 x 20 C18-8	16	-
8	5545201	WASHER M12 SPRING LOCK	16	-
9	5545347	WASHER M12 FLAT WASHER	16	-
10	5533554	NUT M12 x 1.75	16	-
11	5530395	FIG TEE .04 COMP x .04 COMP x .04 COMP	3	-
12	5530089	FIG ELB .06 COMP x .06 NPT	2	-
13	5530106	FIG ELB .04 JIC x 3/8" NPT	1	-
14	5530008	FIG ELB .04 JIC .061 ORB	1	-
15	5545009	WASHER .04 3 x .09mm x .6mm	2	-
16	5530008	SHIM M4 x .07 x 1.2 BCC	2	-
17	5533010	NUT M4 X 0.7 NL	20	-
18	5545338	C WASHER SHIM FOR TIERS	20	-
19	5580012	LIQUID FITT. THREAD SEALANT 50ml	1	-

DO NOT SCALE DRAWING		NAME	DATE	 1645 E BROWNWOOD DR. SANTA PAULA, CA 92360
DRAWN	CA	11/13/2019		
CHECKED	OR	07/20/2021		
DIMENSIONS ARE IN MM		THIRD ANGLE PROJECTION		TITLE: HD-9SW PARTS BAG
				SIZE DWG. NO. B
				A 5174044
PROPRIETARY AND CONFIDENTIAL © 2021 BENDPAK INC. ALL RIGHTS RESERVED. BENDPAK INC. IS A REGISTERED SERVICE MARK OF BENDPAK INC. IN THE U.S. AND OTHER COUNTRIES. BENDPAK INC. IS A REGISTERED TRADEMARK OF BENDPAK INC. IN THE U.S. AND OTHER COUNTRIES.				SCALE: 1:30
				SHEET 1 OF 1

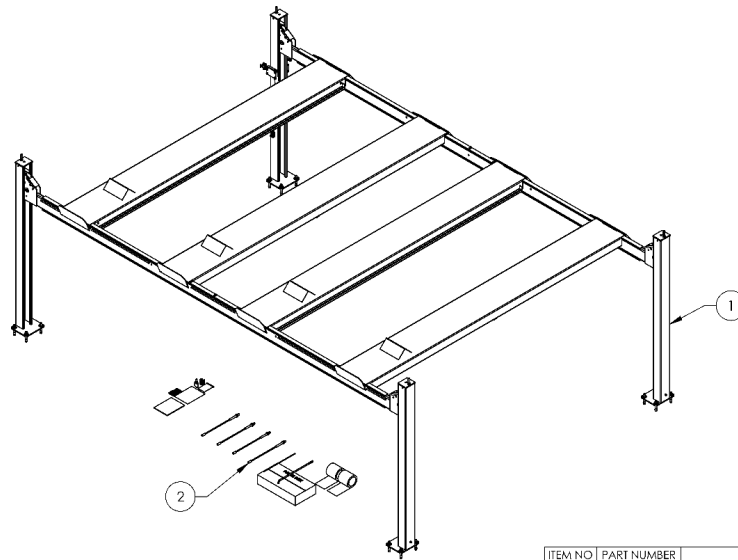

ITEM NO	PART NUMBER	DESCRIPTION	QTY	REV
1	5245080	HD-9SW-E LIFT SUPERSTRUCTURE	1	E
2	5250291	HD-9SW-E PARTS BOX	1	E

DO NOT SCALE DRAWING		NAME	DATE	BP BendPak 445 LEMONWOOD DR. SANTA PAULA, CA 95060
DRAWN	IM	11/ 8/2019		
DIMENSIONS ARE IN INCHES		THIRD ANGLE PROJECTION		TITLE: HD-9SW-E PRODUCTION LIFT VER L (CE CERT)
				SIZE: DWG. NO. 5260462 REV J
<small>PROPRIETARY AND CONFIDENTIAL THE INFORMATION CONTAINED HEREIN IS PROPRIETARY AND CONFIDENTIAL TO BENDPAK. IT IS TO BE USED ONLY FOR THE PURPOSES SPECIFIED HEREIN. NO OTHER REPRODUCTION OR DISSEMINATION IS TO BE MADE WITHOUT THE WRITTEN PERMISSION OF BENDPAK.</small>				SCALE: 1:45 SHEET 1 OF 3

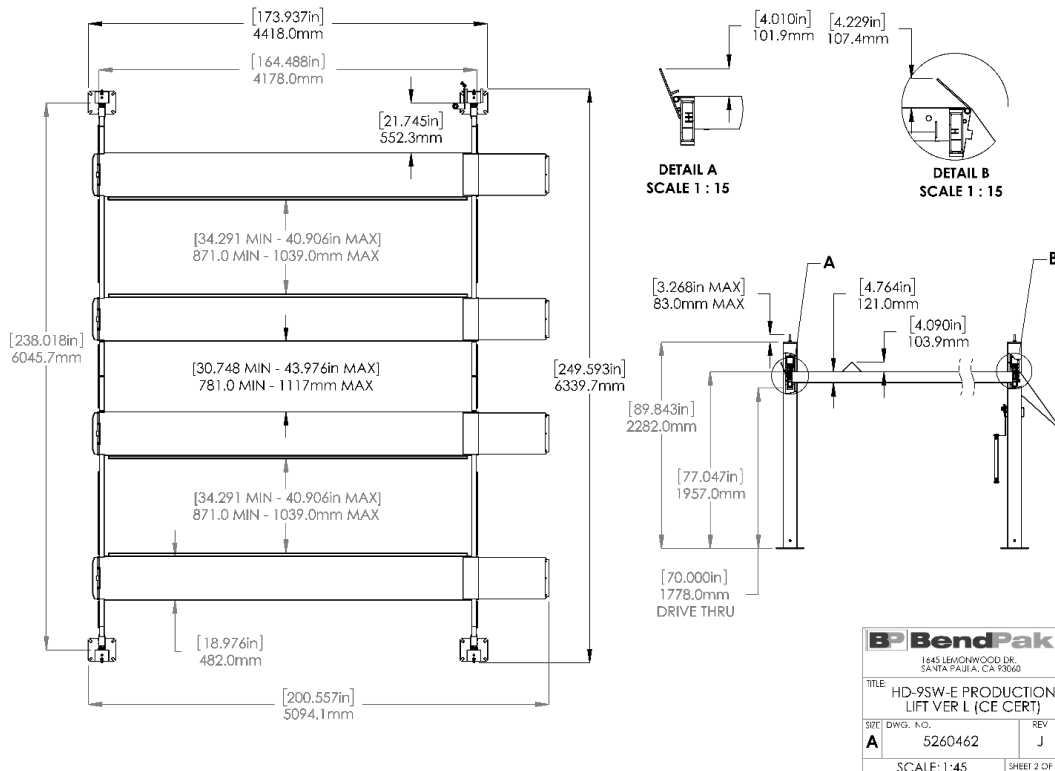

Please note, although the lift's total width dimension spanning the post baseplates is 249.593-inches (6,339mm) bolts located near the bottom of each post, protrude outward approximately 0.50-inch per post; or 1.0-inch(25.4mm) in total. Please be aware of this feature for installs where the lift is placed immediately next to any wall or structure.

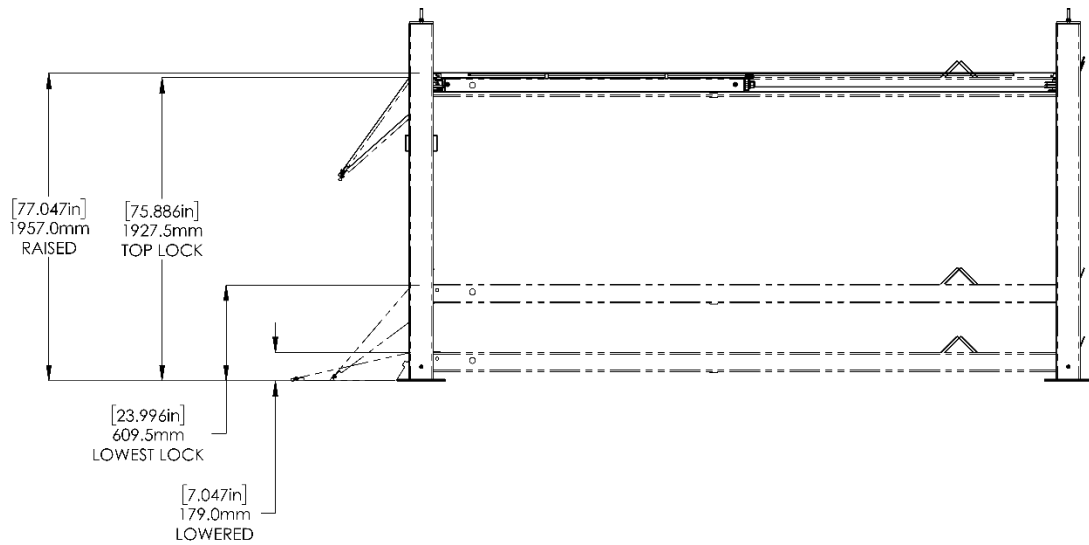

1. DIMENSIONS SHOWN ARE WITH THE LOCK LADDERS ADJUSTED ALL THE WAY UP

BendPak
 1645 LEMONWOOD DR.
 SANTA PAULA, CA 93060

TITLE: HD-9SW-E PRODUCTION LIFT VER L (CE CERT)

SIZE DWG. NO. REV
A 5260462 J

SCALE: 1:30 SHEET 5 OF 3

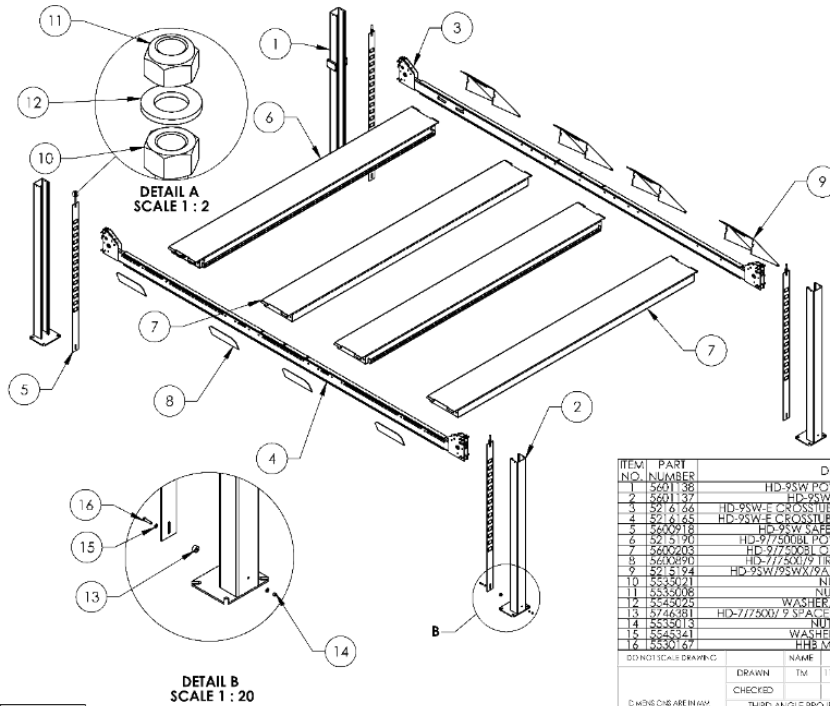

WHERE USED
 HD-9SW-E

ITEM NO.	PART NUMBER	DESCRIPTION	QTY	REV
1	590138	HD-9SW POWER POST WELDMENT	1	A
2	590137	HD-9SW POST WELDMENT	2	A
3	521666	HD-9SW-E CROSS-TUBE ASSEMBLY - SMALL WINDOW	1	A
4	521665	HD-9SW-E CROSS-TUBE ASSEMBLY - LARGE WINDOW	1	A
5	590136	HD-9SW ASSEMBLY LOWER WELDMENT	4	E
6	521290	HD-97/500BL POWER SIDE RAMP ASSEMBLY	1	AC
7	590203	HD-97/500BL OFF SIDE RAMP WELDMENT	2	H
8	590202	HD-97/500BL OFF SIDE RAMP WELDMENT	2	F
9	521594	HD-9SW/92SW/9AE DRIVE UP RAMP ASSEMBLY	4	H
10	5538971	NUT M16 x 2.0	4	-
11	5538908	NUT M16 x 2.0	4	-
12	5542025	WASHER M 6 x 30mm FLAT	4	B
13	5746381	HD-177500/9 SPACER SAFETY LADDER 17.5mm LG	4	B
14	553913	NUT M10 x 1.5 FN	4	-
15	5545841	WASHER M10 x 20 FN AT	8	-
16	5530187	HPB M10 x 1.5 x 45mm	4	-

ISO NOTICAL DRAWING

DRAWN: TM 1/20/2019

CHECKED: [Signature]

THIRD ANGLE PROJECTION

NAME: [Signature] DATE: [Signature]

BendPak
 1645 LEMONWOOD DR.
 SANTA PAULA, CA 93060

TITLE: HD-9SW-E LIFT SUPERSTRUCTURE

SIZE DWG. NO. REV
A 5245080 E

SCALE: 1:50 SHEET 1 OF 1

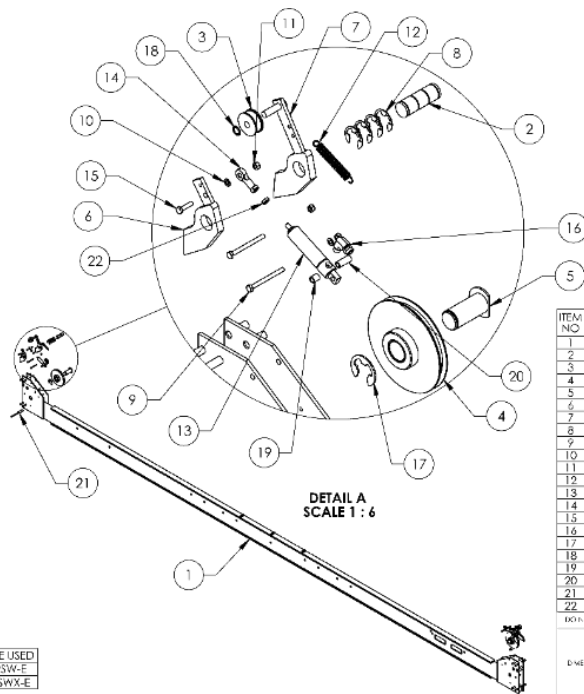

ITEM NO	PART NUMBER	DESCRIPTION	QTY	REV
1	5601829	HD-9SW-E CROSSTUBE WELDMENT, LARGE WINDOW	1	A
2	5746006	D4-12 HD/HDS-77500/9/14 HDQO-14 SAFETY PIN	2	D
3	5575420	HD-77500/9 SAFETY ROLLER	2	C
4	5215122	HD-77500/9 SINGLE SHEAVE ROLLER ASSEMBLY	2	E
5	5600160	HD-77500/9 CROSSTUBE SHEAVE SHAFT WELDMENT	2	G
6	5600760	D4-12 HD/HDS LIGHT DUTY SAFETY WELDMENT	2	C
7	5600044	4 POST LIGHT DUTY SLACK SAFETY WELDMENT	2	F
8	5540275	E RING Ø25mm OD DIN 6799 0250	8	-
9	5502195	HHB M6 x 1.0 x 20	6	-
10	5545005	WASHER, M6 x 12mm FLAT	4	-
11	5535357	NUT M6 x 1.0 NL	8	-
12	5540265	SPRING Ø13mm x 90mm, SLACK SAFETY	2	A
13	5502195	AIR CYLINDER, Ø19mm x 25 STROKE	2	-
14	5505625	FEMALE ROD END M6 x 33	2	-
15	5530756	HHB M6 x 1.0 x 25mm	2	-
16	5500067	FTG ELB. D4 COMP x Ø2 NPT	2	-
17	5540010	E RING Ø32mm OD DIN 6799	2	-
18	5505030	PUSH-ON CLIP Ø10mm SS	2	-
19	5755136	AIR CYLINDER SPACER 12mm	2	A
20	5755137	AIR CYLINDER SPACER 25mm	2	A
21	5755157	D4-12 HD-77500/9 CROSSTUBE SPACER Ø16 x Ø10 x 50	2	A
22	5535230	NUT 1/4-28 JN	2	-

DRAWN: TM 03/02/2022
 CHECKED: [Signature]
 THIRD ANGLE PROJECTION
 TITLE: HD-9SW-E CROSSTUBE ASSEMBLY, LARGE WINDOW
 SIZE: DWG. NO. 5216165
 SCALE: 1:35 SHEET 1 OF 1

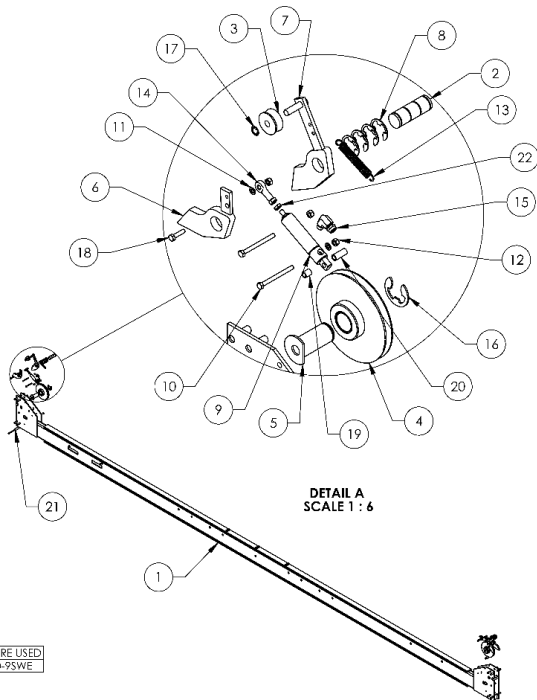

ITEM NO	PART NUMBER	DESCRIPTION	QTY	REV
1	5601830	HD-9SW-E CROSSTUBE WELDMENT, SMALL WINDOW	1	A
2	5746006	D4-12 HD/HDS-77500/9/14 HDQO-14 SAFETY PIN	2	D
3	5575420	HD-77500/9 SAFETY ROLLER	2	C
4	5215122	HD-77500/9 SINGLE SHEAVE ROLLER ASSEMBLY	2	E
5	5600160	HD-77500/9 CROSSTUBE SHEAVE SHAFT WELDMENT	2	G
6	5600760	D4-12 HD/HDS LIGHT DUTY SAFETY WELDMENT	2	C
7	5600044	4 POST LIGHT DUTY SLACK SAFETY WELDMENT	2	F
8	5540275	E RING Ø25mm OD DIN 6799 0250	8	-
9	5502195	AIR CYLINDER, Ø19mm x 25 STROKE	2	-
10	5545005	HHB M6 x 1.0 x 20	6	-
11	5535357	WASHER, M6 x 12mm FLAT	4	-
12	5535357	NUT M6 x 1.0 NL	8	-
13	5540265	SPRING Ø13mm x 90mm, SLACK SAFETY	2	A
14	5505625	FEMALE ROD END M6 x 33	2	-
15	5530087	FTG ELB. D4 COMP x Ø2 NPT	2	-
16	5540010	E RING Ø32mm OD DIN 6799	2	-
17	5505030	PUSH-ON CLIP Ø10mm SS	2	-
18	5530756	HHB M6 x 1.0 x 25mm	2	-
19	5755136	AIR CYLINDER SPACER 12mm	2	A
20	5755137	AIR CYLINDER SPACER 25mm	2	A
21	5755157	D4-12 HD-77500/9 CROSSTUBE SPACER Ø16 x Ø10 x 50	2	A
22	5535230	NUT 1/4-28 JN	2	-

DRAWN: TM 03/02/2022
 CHECKED: [Signature]
 THIRD ANGLE PROJECTION
 TITLE: HD-9SW-E CROSSTUBE ASSEMBLY, SMALL WINDOW
 SIZE: DWG. NO. 5216166
 SCALE: 1:35 SHEET 1 OF 1

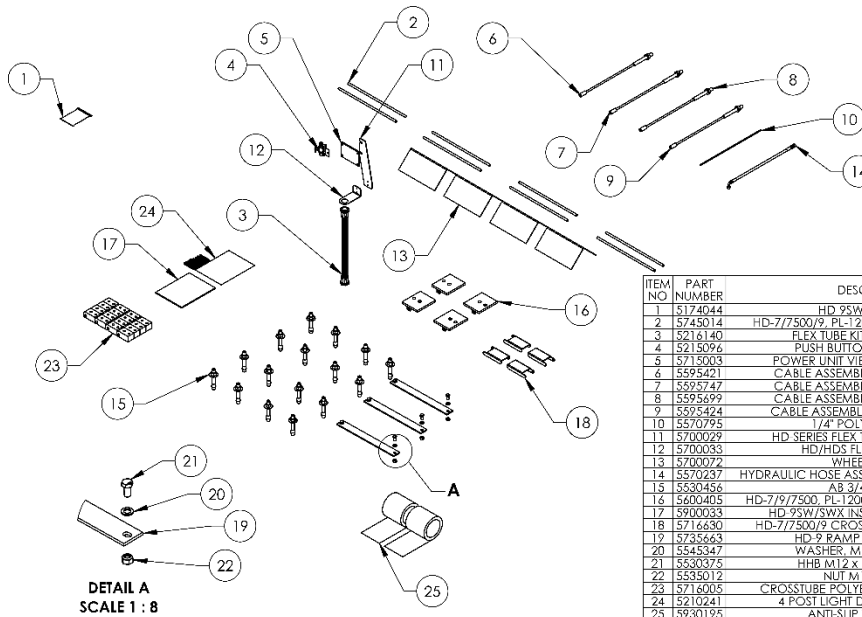

DETAIL A
SCALE 1 : 8

WHERE USED
HD-9SW-E

NOTE: UNLESS OTHERWISE SPECIFIED

1. SEE SHIPPING INSTRUCTIONS FOR FINAL PACKAGING
2. HOSES AND CABLES IN REPRESENTATIONAL FORM
3. (*) LENGTH FOR REFERENCE ONLY

ITEM NO	PART NUMBER	DESCRIPTION	QTY	REV
1	S174044	HD 9SW PARTS BAG	1	B
2	S745014	HD-777500/9, PL-12000 DRIVE UP RAMP PIN	8	B
3	S216140	FLEX TUBE KIT, UP TO 2500mm	1	A
4	S215096	PUSH BUTTON AIR ASSEMBLY	1	G
5	S713003	POWER UNIT VIBRATION DAMPENER	1	B
6	S595421	CABLE ASSEMBLY Ø10 x 3313mm ST	1	C
7	S595747	CABLE ASSEMBLY Ø10 x 7772mm ST	1	A
8	S595699	CABLE ASSEMBLY Ø10 x 7450mm ST	1	A
9	S595424	CABLE ASSEMBLY Ø10 x 11334mm ST	1	C
10	S570795	1/4" POLY-FLO TUBING	21000mm*	-
11	S700029	HD SERIES FLEX TUBE BRACKET PLATE	1	F
12	S700033	HD/HDS FLEX TUBE ANGLE	1	E
13	S700072	WHEEL CHOCK	4	B
14	S570237	HYDRAULIC HOSE ASSEMBLY Ø6.4 x 3530mm SB	1	A
15	S530456	AB 3/4" x 4 - 3/4"	16	-
16	S600405	HD-7/9/7500, PL-12000 TOP PLATE WELDMENT	4	C
17	S900033	HD 9SW/SWX INSTALLATION MANUAL	1	-
18	S716630	HD-777500/9 CROSS-TUBE COVER, PLASTIC	4	A
19	S735663	HD-9 RAMP STRAP, BOLT ON	3	B
20	S545347	WASHER, M12 FLAT WASHER	6	-
21	S530375	HHB M12 x 1.75 x 25 CL12.9	6	-
22	S535012	NUT M12 x 1.75 NL	6	-
23	S718005	CROSS-TUBE POLYETHYLENE SLIDE BLOCK	16	M
24	S210241	4 POST LIGHT DUTY CE PARTS BAG	1	A
25	S930125	ANTI-SLIP TAPE, 6" x 24ft	2	-

BENDPAK 1441 BEND-ROCKED DR. SANTA PAULA, CA 93060	
DRAWN: IM 1/18/2019 CHECKED: OR 08/23/2022 TITLED: ANGLE PROJECTION	TITLE: HD-9SW-E PARTS BOX SIZE: A DWG. NO: 5250291 REV: F SCALE: 1:25 SHEET 1 OF 1

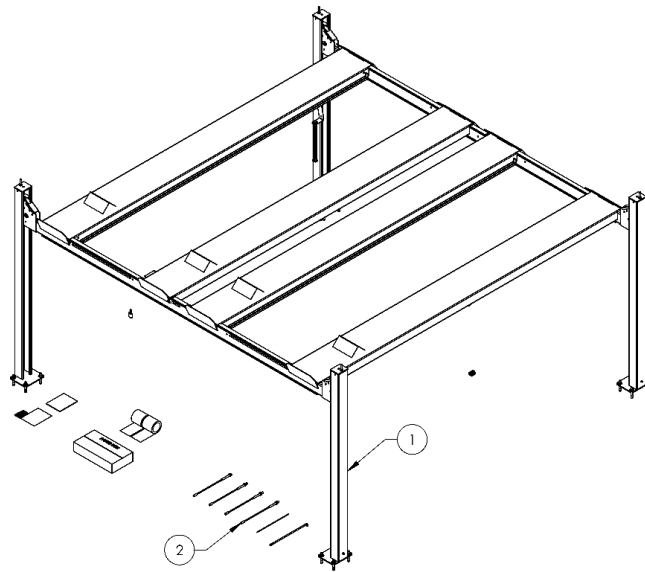

ITEM NO.	PART NUMBER	DESCRIPTION	QTY	REV
1	5245079	HD-9SWX LIFT SUPERSTRUCTURE	1	E
2	5250290	HD-9SWX PARTS BOX	1	E

3D ISOMETRIC DRAWING	NAME	DATE	BendPak	
	DRAWN	CA 11/13/2019	245 LEMWOOD DR. SANTA ANA, CA 92700	
	CHECKED	OK 06/14/2022		

THIRD ANGLE PROJECTION		TITLE	REV
		HD-9SWX PRODUCTION LIFT VER L (CE CERT)	J
SHEET	DWG. NO.	REV	
A	5260594	J	
SCALE: 1:45		SHEET OF 4	

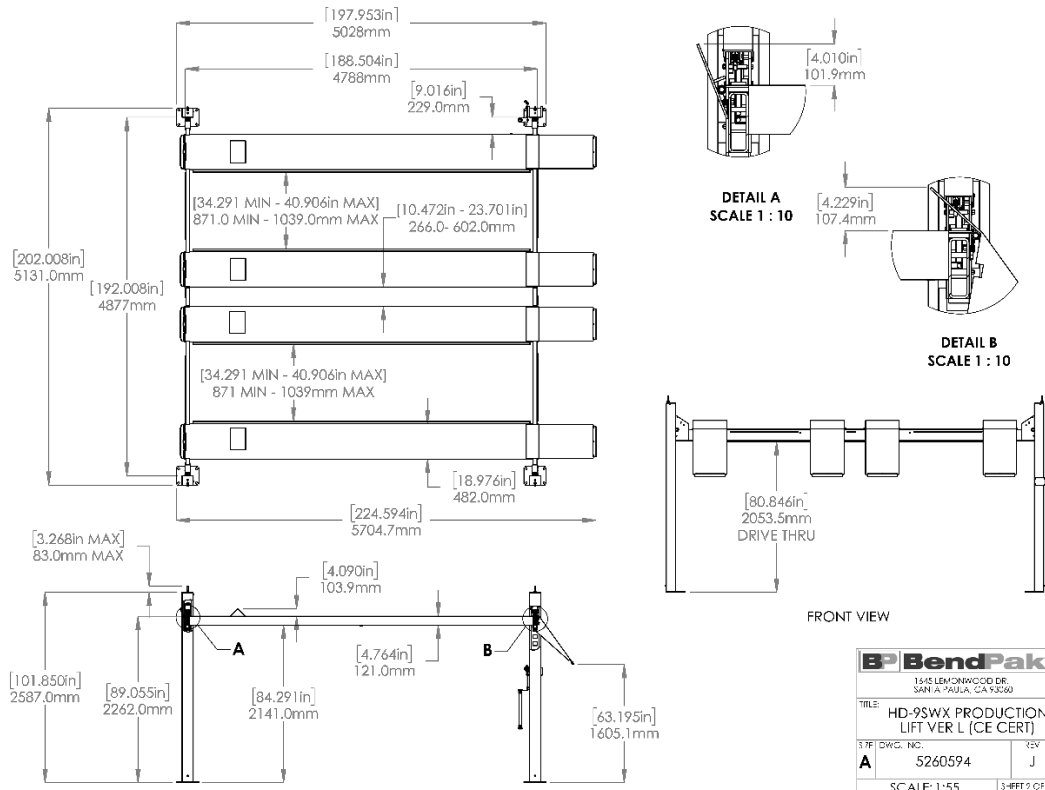

BendPak	
1545 LEMWOOD DR. SANTA ANA, CA 92700	
TITLE: HD-9SWX PRODUCTION LIFT VER L (CE CERT)	
SHEET	DWG. NO.
A	5260594
SCALE: 1:55	
SHEET OF 4	

Please note, although the lift's total width dimension spanning the post baseplates is 249.593-inches (6,339mm) bolts located near the bottom of each post, protrude outward approximately 0.50-inch per post; or 1.0-inch(25.4mm) in total. Please be aware of this feature for installs where the lift is placed immediately next to any wall or structure.

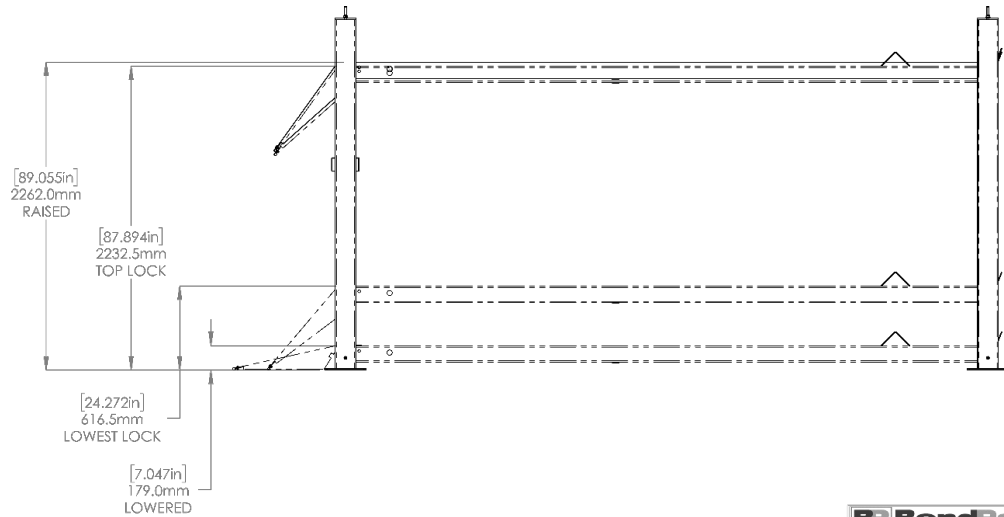

1. ALL DIMENSIONS SHOWN ARE WITH LOCK LADDER ADJUSTED ALL THE WAY UP

BendPak
 1645 LEMO WOOD DR.
 SANTA RITA, CA 95050

TITLE: HD-9SWX PRODUCTION LIFT VER L (CE CERT)

SIZE DWG. NO. REV
A 5260594 J

SCALE: 1:30 SHEET 3 OF 4

5175560 - PACKAGE 1				
ITEM NO	PART NUMBER	DESCRIPTION	QTY	REV
1	5216164	HD-9SW CROSSTUBE ASSEMBLY, SMALL WINDOW	1	A
2	5216163	HD-9SW CROSSTUBE ASSEMBLY, LARGE WINDOW	1	A
3	5600917	HD-9SWX SAFETY LADDER WELDMENT	4	B
4	5215192	HD-9/7500BLX POWER SIDE RAMP ASSEMBLY	1	AD
5	5600890	HD-7/7500/9 TIRE STOP PLATE WELDMENT	4	F
6	5600205	HD-9/7500BLX OFF SIDE RAMP WELDMENT	1	K
7	5215194	HD-9SW/9SWX/9AE DRIVE UP RAMP ASSEMBLY	4	H
8	5535021	NUT M16 x 2.0	4	--
9	5535008	NUT M16 x 2 NL	4	--
10	5545025	WASHER, M16 x 30mm FLAT	4	--
11	5746381	HD-7/7500/ 9 SPACER, SAFETY LADDER, 17.5mm LG	4	B
12	5535013	NUT M10 x 1.5 NL	4	--
13	5545341	WASHER M10 x Ø20 FLAT	8	--
14	5530167	HHB M10 x 1.5 x 45mm	4	--

5175561 - PACKAGE 2				
ITEM NO	PART NUMBER	DESCRIPTION	QTY	REV
1	5601127	HD-9SWX POWER POST WELDMENT	1	A
2	5601126	HD-9SWX POST WELDMENT	3	A
3	5600205	HD-9/7500BLX OFF SIDE RAMP WELDMENT	2	K
4	5250290	HD-9SWX PARTS BOX	1	E

BendPak
 1645 LEMO WOOD DR.
 SANTA RITA, CA 95050

TITLE: HD-9SWX PRODUCTION LIFT VER L (CE CERT)

SIZE DWG. NO. REV
A 5260594 J

SHEET 4 OF 4

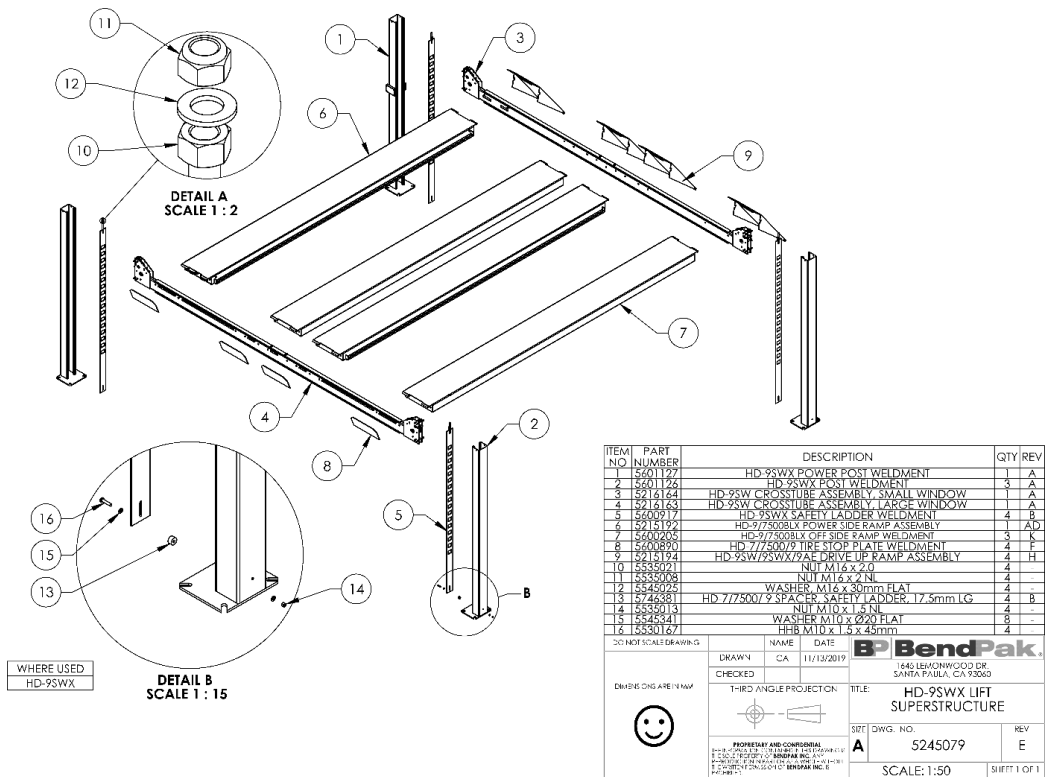

ITEM NO.	PART NUMBER	DESCRIPTION	QTY	REV
1	5601924	HD-9SWX POWER POST WELDMENT	1	A
2	5601926	HD-9SWX POST WELDMENT	5	A
3	5218144	HD-9SW CROSS-TUBE ASSEMBLY SMALL WINDOW	1	A
4	5218145	HD-9SW CROSS-TUBE ASSEMBLY LARGE WINDOW	1	A
5	5600917	HD-9SWX SAFETY LADDER WELDMENT	4	B
6	5600925	HD-97500BLX POWER SIDE RAMP ASSEMBLY	1	AD
7	5600926	HD-97500BLX OFF-SIDE RAMP ASSEMBLY	1	AD
8	5600890	HD-77500/9 TIRE STOP PLATE WELDMENT	4	F
9	5218174	HD-9SW/7500/9 DRIVE UP RAMP ASSEMBLY	4	H
10	5535021	NUT M16 x 2.0	4	-
11	5535026	NUT M14 x 2.0	4	-
12	5535025	WASHER M16 x 30mm FLAT	4	-
13	5745381	HD-77500/9 SPACER SAFETY LADDER 17.5mm LG	2	B
14	5535013	NUT M10 x 1.5 NL	4	-
15	5535041	WASHER M10 x 22.0 FLAT	8	-
16	5530167	HHB M10 x 1.5 x 45mm	4	-

DO NOT SCALE DRAWING

DRAWN: CA 11/13/2019
 CHECKED: CA 11/13/2019

NAME: DATE: **BendPak**
 1445 BLENKWOOD DR.
 SANTA PAULA, CA 93060

EMERSON ARE NEW
 THIRD ANGLE PROJECTION

TITLE: HD-9SWX LIFT SUPERSTRUCTURE

SPEC DWG. NO. REV
 A 5245079 E

SCALE: 1:50 SHEET 1 OF 1

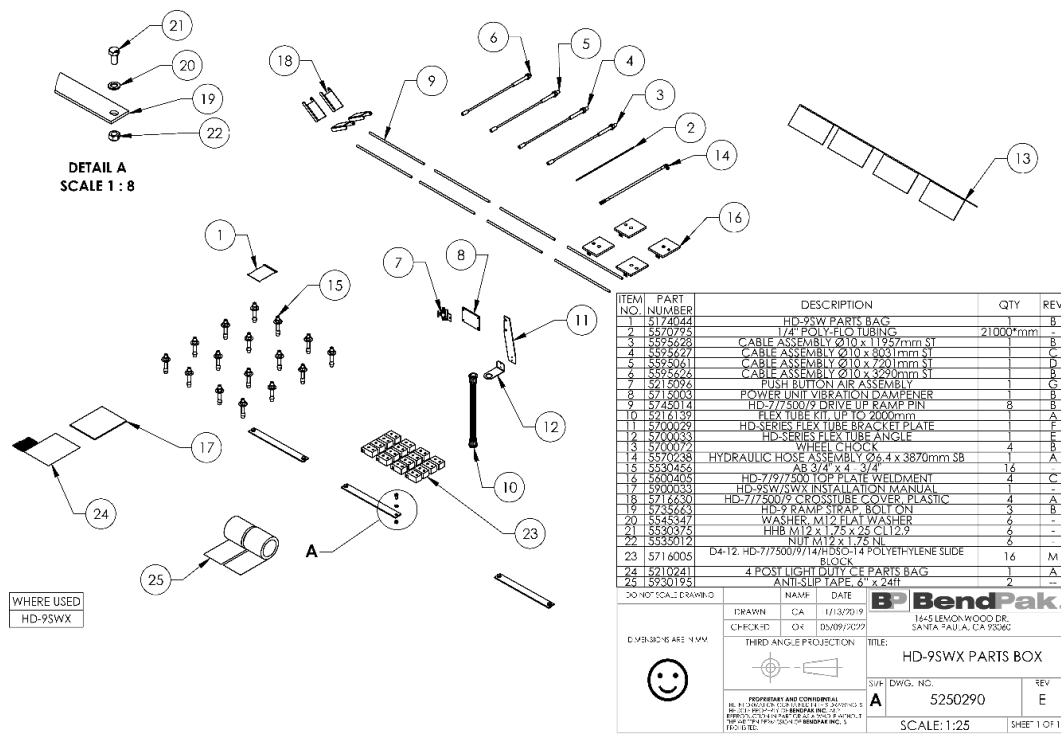

ITEM NO.	PART NUMBER	DESCRIPTION	QTY	REV
1	5174044	HD-9SWX PARTS BAG		B
2	5579795	1/4" POLY-ETHYLENE TUBING	21000	mm
3	5575268	CABLE ASSEMBLY 5010 x 1195 mm ST	1	B
4	5575277	CABLE ASSEMBLY 5010 x 803 mm ST	1	C
5	5575261	CABLE ASSEMBLY 5010 x 720 mm ST	1	D
6	5575262	CABLE ASSEMBLY 5010 x 542 mm ST	1	B
7	5215026	PUSH BUTTON AIR ASSEMBLY	1	G
8	5215003	POWER UNIT VIBRATION DAMPENER	1	B
9	5745012	HD-77500/9 DRIVE UP RAMP PIN	8	B
10	5216139	FLEX TUBE KIT UP TO 2000mm	1	A
11	5200929	HD-SERIES FLEX TUBE BRACKET PLATE	1	F
12	5200933	HD-SERIES FLEX TUBE ANGLE	1	F
13	5700079	WHEEL CHOCK	4	B
14	5570288	HYDRAULIC HOSE ASSEMBLY 95.4 x 3870mm SB	1	A
15	5530456	AB 3/4" x 4" 3/4"	16	A
16	5600405	HD-77500 TOP PLATE WELDMENT	4	C
17	5600935	HD-9SWX INSTALLATION MANUAL	1	-
18	5716330	HD-77500/9 CROSS-TUBE COVER PLASTIC	4	A
19	5735263	HD-9 RAMP STRAP BOLT ON	3	B
20	5535042	WASHER M12 x 1.75 x 22 C112.9	6	-
21	5535075	HHB M12 x 1.75 x 22 C112.9	6	-
22	5535012	NUT M12 x 1.75 NL	6	-
23	5716005	D4-12 HD-77500/9 HD-97500/4 POLY-ETHYLENE SLIDE BLOCK	16	M
24	5710741	4 POST LIGHT DUTY LIFT PARTS BAG	1	A
25	5530193	ANTI-SLIP TAPE 6" x 24"	2	-

DO NOT SCALE DRAWING

DRAWN: CA 11/13/2019
 CHECKED: CA 06/09/2022

NAME: DATE: **BendPak**
 1445 BLENKWOOD DR.
 SANTA PAULA, CA 93060

EMERSON ARE NEW
 THIRD ANGLE PROJECTION

TITLE: HD-9SWX PARTS BOX

SPEC DWG. NO. REV
 A 5250290 E

SCALE: 1:25 SHEET 1 OF 1



1645 Lemonwood Drive
Santa Paula, CA, 93060 USA