

10AP-SRT/12AP-SRT Short-Column, Short-Rise, Two-Post Lift Installation and Operation Manual

Manual P/N 5900354 — Manual Revision B1 — June 2024

Models:

- 10AP-SRT
- 12AP-SRT

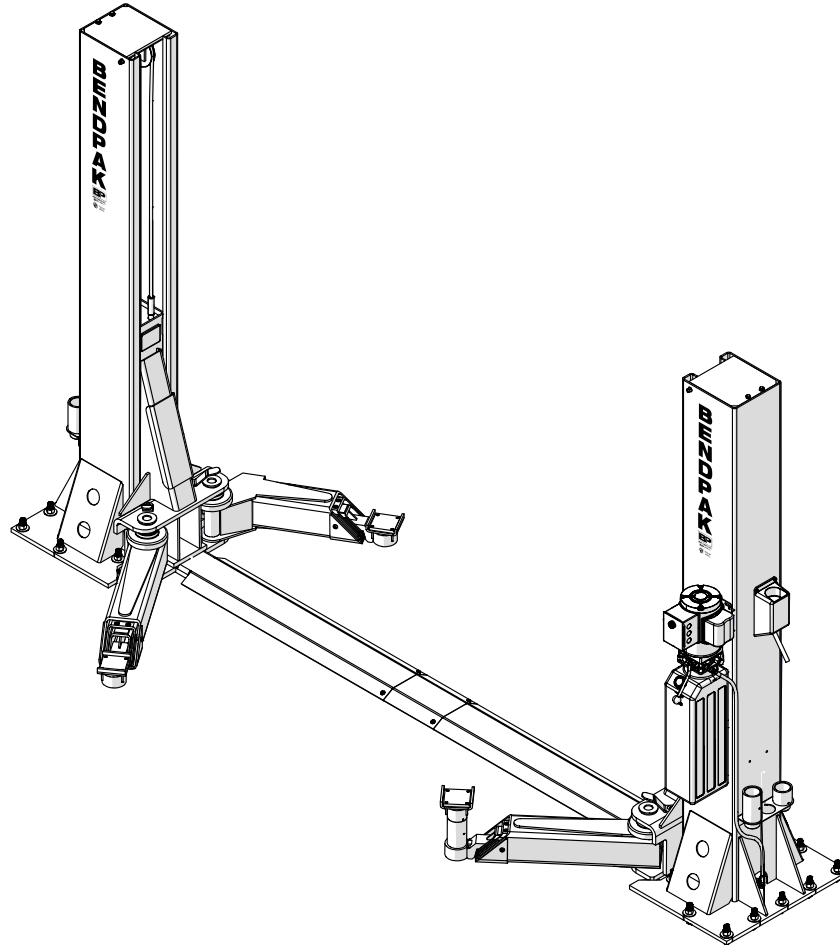

*Original Instructions in
the English language.*

Designed and engineered by BendPak Inc. in Southern California, USA. Made in China.

 **DANGER**

IMPORTANT SAFETY INSTRUCTIONS, SAVE THESE INSTRUCTIONS! Read the entire contents of this manual **before** using this product. Failure to follow the instructions and safety precautions in this manual can result in severe injury or death. Make sure all other operators also read this manual. Keep the manual near the product for future reference. **By proceeding with setup and operation, you agree that you fully understand the contents of this manual and assume full responsibility for product use.**

Manual. 10AP-SRT/12AP-SRT Short-Column, Short-Rise, Two-Post Lift, *Installation and Operation Manual*, Manual Part Number 5900354, Manual Revision B1, released June 2024.

Copyright. Copyright © 2024 by BendPak Inc. All rights reserved. You may make copies of this document if you agree that: full attribution goes to BendPak Inc., you are not authorized to make changes to the content, you do not gain any rights to this content, and you will not use the copies for commercial purposes.

Trademarks. BendPak and the BendPak logo are registered trademarks of BendPak Inc. All other company, product, and service names are used for identification only. All trademarks and registered trademarks mentioned in this manual are the property of their respective owners.

Limitations. Every effort has been made to ensure complete and accurate instructions are included in this manual. However, product updates, revisions, and/or changes may have occurred since this manual was published. BendPak reserves the right to change any information in this manual without incurring any obligation for equipment previously or subsequently sold. All drawings are reference only – do not scale. BendPak is not responsible for typographical errors in this manual. You can always find the latest version of the **manual for your product on the BendPak website.**



SCAN FOR
DIGITAL PDF

Warranty. The BendPak warranty is more than a commitment to you: it is also a commitment to the value of your new product. Contact your nearest BendPak dealer or visit www.bendpak.com/support/warranty for full warranty details. Go to bendpak.com/support/register-your-product/ and fill out the online form to register your product (be sure to click **Submit**).

Safety. Your Lift was designed and manufactured with safety in mind. Your safety also depends on proper training and thoughtful operation. Do not set up, operate, maintain, or repair the Lift without reading and understanding this manual and the labels on the unit; **do not use your Lift unless you can do so safely!**

Owner Responsibility. To maintain your product properly and to ensure operator safety, it is the responsibility of the product owner to read and follow these instructions:

- Follow all installation, operation, and maintenance instructions.
- Make sure product installation conforms to all applicable local, state, and federal codes, rules, and regulations, such as state and federal OSHA regulations and electrical codes.
- Read and follow all safety instructions. Keep them readily available for operators.
- Make sure all operators are properly trained, know how to safely operate the unit, and are properly supervised.
- Do not operate the product until you are certain all parts are in place and operating correctly.
- Carefully inspect the product on a regular basis and perform all maintenance as required.
- Service and maintain the unit only with approved replacement parts.
- Keep the manual with the product and make sure all labels are clean and visible.
- **BendPak** makes no promises, guarantees or assurances that our products meet any state, county, federal or international mandated permit, license, code, standard, certification, or any other mandate other than what is listed or shown on BendPak website(s), or any BendPak online or published catalog. Not all BendPak lift models meet the standards as prescribed by ANSI/ALI ALCTV-(current edition) or ANSI/UL 201. Consult www.autolift.org for a complete list of lift models that meet ANSI/ALI ALCTV-(current edition) or ANSI/UL 201, or contact BendPak via www.bendpak.com/contact/ **Buyer assumes full responsibility for any state, county, federal or international mandated permit, license, code, standard, certification, or any other mandate required related to the installation and/or operation of any BendPak or Autostacker product.** BendPak will not be responsible for any charges, fines, liens, or other levies imposed on the Buyer related to any special or regional structural, seismic or any other building code and/or codes such as the Uniform Building Code (UBC), International Building Code (IBC), or any other state, county, federal or international mandated permit, license, code, standard, certification, or other mandate, law, rule, regulation or directive by any other agency, government, administrations, or corporations whether state, county, federal, or international mandated.
- **Only use the Lift if it can be used safely!**

Unit Information. Enter the Model Number, Serial Number, and the Date of Manufacture from the ID label on your unit. This information is required for part or warranty issues.

Model: _____

Serial: _____

Date of Manufacture: _____

- 110-120V, 50-60 Hz, 1 Ph
- 208-240V, 50-60 Hz, 1 Ph
- 380-415V, 50-60 Hz, 3 Ph
- 208-440V, 50-60 Hz, 3 Ph

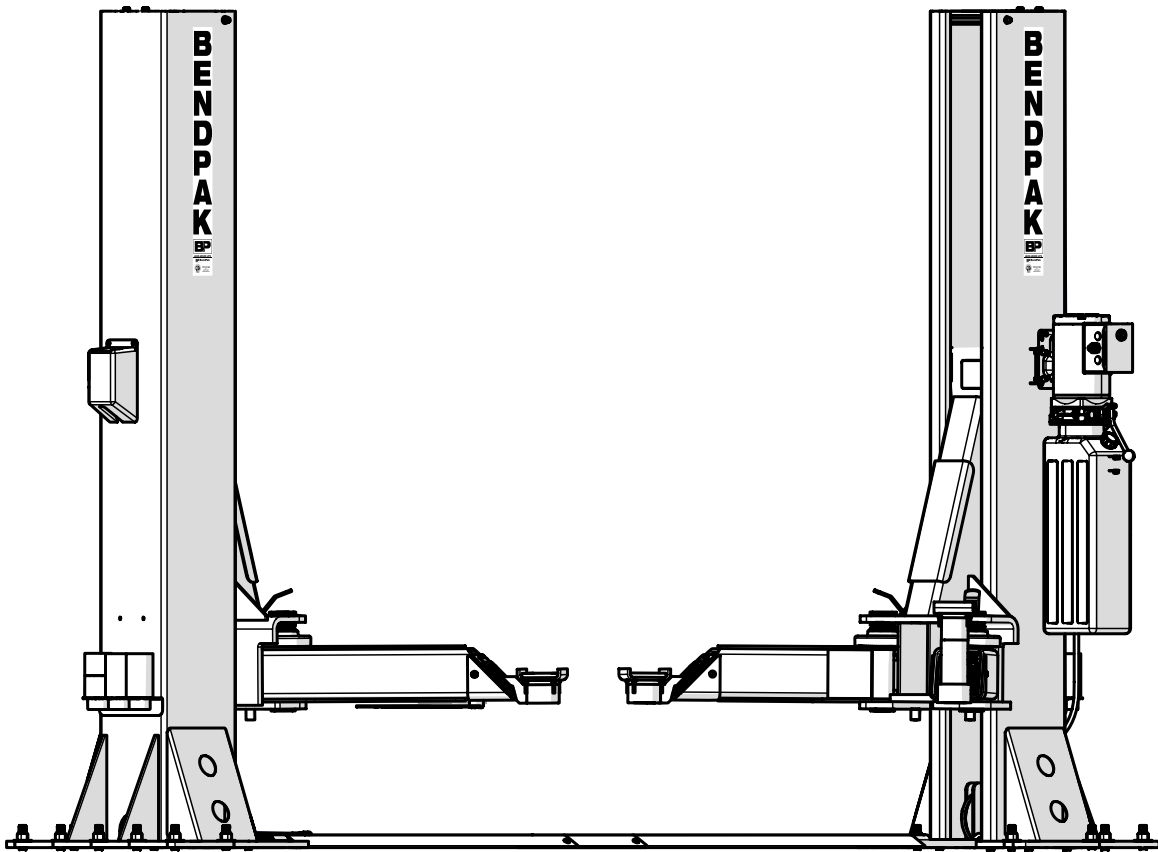

Table of Contents

Introduction	4	Operation	57
Shipping Information	5	Maintenance	67
Safety Considerations	5	Troubleshooting	73
FAQ	8	Wiring Diagrams	77
Components	9	Labels	80
Specifications	10	Parts Drawings	83
Installation Checklist	14	ALI Store	101
Installation	15	Maintenance Log	102

Introduction

This manual describes the **10AP-SRT** and **12AP-SRT** Short-Column, Short-Rise, Two-Post Lifts. More information about the full line of BendPak products is available at [bendpak.com](https://www.bendpak.com).

⚠ DANGER Be very careful when installing, operating, maintaining, or repairing this equipment; failure to do so could result in property damage, product damage, injury, or (in very rare cases) death. Make sure only authorized personnel operate this equipment. An authorized technician must perform all repairs. Do not make modifications to the unit; this voids the warranty and increases the chances of injury or property damage. Make sure to read and follow the instructions on the labels on the unit.

This manual is mandatory reading for all user/operators of the 10AP-SRT and 12AP-SRT Lifts, including anyone who installs, operates, maintains, or repairs them. Always keep this manual on or near the equipment.

Technical support and service is available from your dealer, on the Web at [bendpak.com/support](https://www.bendpak.com/support), by email at support@bendpak.com, or by phone at **(800) 253-2363**, option 7, then 4.

Online chat is also available at www.bendpak.com click the chat icon. 

Scan this QR Code for up-to-date information and videos on the BendPak Lift series.



SCAN FOR VIDEO

Shipping Information

Your equipment was carefully checked before shipping. Nevertheless, you should thoroughly inspect the shipment **before** you sign to acknowledge that you received it.

When you sign the bill of lading, it tells the carrier that the items on the invoice were received in good condition. **Do not sign the bill of lading until after you have inspected the shipment.** If any of the items listed on the bill of lading are missing or damaged, do not accept the shipment until the carrier makes a notation on the bill of lading that lists the missing or damaged goods.

If you discover missing or damaged goods **after** you receive the shipment and have signed the bill of lading, notify the carrier at once and request the carrier to make an inspection. If the carrier will not make an inspection, prepare a signed statement to the effect that you have notified the carrier (on a specific date), and that the carrier has failed to comply with your request.

It is difficult to collect for loss or damage after you have given the carrier a signed bill of lading. If this happens to you, file a claim with the carrier promptly. Support your claim with copies of the bill of lading, freight bill, invoice, and photographs, if available. Our willingness to assist in helping you process your claim does not make us responsible for collection of claims or replacement of lost or damaged materials.

Safety Considerations

Read this entire manual carefully before using your new product. Do not install or operate the product until you are familiar with all operating instructions and warnings. Refer to ANSI/ALI ALIS Standard *Safety Requirements for Installation and Service of Automotive Lifts* for more information about safely installing your Lift.

 **WARNING** **California Proposition 65.** This product can expose you to chemicals including styrene and vinyl chloride which are on the list of over 900 chemicals identified by the State of California to cause cancer, birth defects or reproductive harm. **ALWAYS** use this product in accordance with BendPak's instructions. For more information go to www.P65Warnings.ca.gov.

IMPORTANT SAFETY INSTRUCTIONS!

SAVE THESE INSTRUCTIONS!





1. Read all instructions.
2. Care must be taken as burns can occur from touching hot parts.
3. Do not operate equipment with a damaged cord or if the equipment has been dropped or damaged – until a qualified service person has examined it.
4. Do not let a cord hang over the edge of a table, bench, or counter or come in contact with hot manifolds or moving fan blades.
5. If an extension cord is necessary, a cord with a current rating equal to or more than that of the equipment should be used. Cords with a current rating less than the equipment may overheat. Care should be taken to arrange the cord so that it will not be tripped over or pulled.

-
6. Always unplug the equipment from the electrical outlet when not in use. Never use the cord to pull the plug from the outlet. Grasp the plug and pull to disconnect.
 7. Let the equipment cool completely before putting it away. Loop cord loosely around equipment when storing.
 8. To reduce the risk of fire, do not operate in the vicinity of open containers of flammable liquids (gasoline).
 9. Adequate ventilation should be provided when working on operating internal combustion engines.
 10. Keep hair, loose clothing, fingers, and all parts of body away from moving parts.
 11. To reduce the risk of electric shock, do not use on wet surfaces or expose to rain.
 12. Use only as described in this manual. Use only BendPak recommended attachments.
 13. ALWAYS WEAR SAFETY GLASSES. Everyday eyeglasses only have impact resistant lenses, they are not safety glasses.
 14. Guard against electric shock. This Lift must be grounded while in use to protect the operator. Never connect the green power cord wire to a live terminal.
 15. To reduce the risk of injury, close supervision is necessary when this product is used around children.
 16. To reduce the risk of injury, **never** attempt to lift more than the rated capacity. Refer to loading instructions.
 17. The Lift uses electrical energy; if your organization has Lockout/Tagout policies, make sure to implement them after connecting the Lift to a power source.
 18. Refer to markings for proper load on electrical receptacles.
 19. Only operate your Lift between temperatures of +41°F to +104°F (+5°C to +40°C).
 20. The Lift should **only** be operated by authorized personnel. Keep children and untrained personnel away from the Lift.
 21. Do not make any modifications to the Lift; this voids the warranty and increases the chances of injury or property damage.
 22. Do not use the Lift while tired or under the influence of drugs, alcohol, or medication.
 23. Consider the work environment. Keep the work area clean. Cluttered work areas invite injuries. Keep areas well lit.
 24. **Always** make sure the Lift is secured on safety locks before attempting to work on or near a vehicle.
 25. Make a thorough inspection of the product at least once a year. Replace any damaged or severely worn parts, decals, or warning labels. Replace worn or damaged parts with BendPak or BendPak approved parts and assemblies only.
 26. BendPak recommends referring to the ANSI/ALI ALIS Standard *Safety Requirements for Installation and Service* for more information about safely installing, using, and servicing your Lift.
 27. **10AP-SRT** and **12AP-SRT Lifts** are Two-Post Short-Rise Service Lifts. **Use them only for their intended purpose.**
 28. You **must** always wear OSHA-approved (publication 3151) personal protective equipment when installing, using, maintaining, or repairing the Lift. Leather gloves, steel-toed work boots, eye protection, back belts, and hearing protection are **mandatory**.

-
29. Keep loads balanced on the lift arms. Clear the area immediately if a vehicle is in danger of falling off the Lift. Do not make any modifications to the Lift.
 30. Modifications void the warranty and increase the chances of injury or property damage. *Do not modify any safety-related features in any way.*
 31. Make sure all operators read and understand this Installation and Operation Manual. *Always keep the manual near the Lift.*
 32. While handling a hydraulic cylinder or a hydraulic hose, **always** wear gloves. In rare cases, a needle-like stream of hydraulic fluid (even at low pressure) can penetrate fingers, hands, or arms; such a puncture can feel like a bite, electric shock, or a prick. While it may seem like a minor issue, any amount of hydraulic fluid injected into the human body is a serious issue. Anyone suffering such a puncture wound should be **immediately** taken to a hospital emergency room to determine the extent of the injury. Explain the circumstances of the injury to the attending physician, including what kind of hydraulic fluid was involved. Do not assume a puncture wound that could have been caused by hydraulic fluid is a minor issue; it could be life threatening.
 33. Inspect the Lift **before** using it. Check for damaged, worn, or missing parts. Do not use it if you find any of these issues. Instead, take it out of service, then contact an authorized repair facility, your dealer, or BendPak at **(800) 253-2363**, option 7 then 4, or support@BendPak.com.

Symbols

Following are the symbols used in this manual:

-  **DANGER** Calls attention to an immediate hazard that **will** result in injury or death.
-  **WARNING** Calls attention to a hazard or unsafe practice that **could** result in injury or death.
-  **CAUTION** Calls attention to a hazard or unsafe practice that could result in minor personal injury, product, or property damage.
- NOTICE** Calls attention to a situation that, if not avoided, could result in product or property damage.
-  **Tip** Calls attention to information that can help you use your product better.

Liability Information

BendPak Inc. assumes **no** liability for damages resulting from:

- Use of the product for purposes other than those described in this manual.
- Modifications to the equipment without prior written permission from BendPak Inc.
- Injury or death caused by modifying, disabling, overriding, or removing safety features.
- Damage to the equipment from external influences.
- Incorrect operation of the equipment.

Frequently Asked Questions

Question: What kinds of vehicles can be raised on the **12AP-SRT** Lift?

Answer: Cars, trucks, SUVs, or similar; up to 12,000 lbs. (5,443 kg) each.

Q: What kinds of vehicles can be raised on the **10AP-SRT** Lift?

A: Cars, trucks, SUVs, or similar; up to 10,000 lbs. (4,536 kg) each.

Q: How long will it take to raise or lower the vehicle?

A: Anywhere from 30 to 45 seconds, depending on how high it is raised.

Q: Does the Lift have to be anchored in place?

A: Yes. Two-Post Lifts **must** be anchored. The Lift is supplied with high-quality anchor bolts; use only the anchor bolts that are supplied with your Lift.

Q: How thick does my concrete need to be?

A: The 12AP-SRT requires concrete that is 6.5 inches thick and the 10AP-SRT requires 4.25 inches. All concrete must be steel reinforced, 3,000 psi minimum compressive strength, cured for 28 days minimum. Do not install the Lift on cracked or defective concrete. **Do not install on asphalt or any surface other than steel reinforced concrete.**

Q: Can I install my Lift outside?

A: No. **Outdoor installation is prohibited.** All 10 and 12AP-SRT Series Lifts are approved for indoor installation and use only.

Q: How many safety lock positions does my Lift have?

A: 8 safety locks. One lock positioned every 3.75 in. (95 mm).

Q: Does the Lift have a Front and Rear?

A: Yes and no. Because vehicles may be driven onto a Two-Post Lift from either opening, there is technically no Front or Rear. However, most garages have an Approach side and a Wall side, so in that case, the Wall side is the Front, and the Approach side is the Rear.

Q: How long can a vehicle be left raised up on my Lift?

A: For a long time, if you leave the Lift *engaged* on its safety locks. Once the Lift is engaged on its safety locks, gravity holds it in position. **Only leave your Lift either on the ground (fully lowered) or engaged on its safety locks.**

⚠ DANGER Never move or work under a vehicle on the Lift unless both lift heads are engaged on their safety locks and the vehicle is stable on the lift arms.

Q: How do I know where to put the adapters when I want to raise a vehicle?

A: The vehicle must be balanced on the Lift, so you must position the adapters (sometimes called Pads) so that they contact the manufacturer's recommended lifting points. **If you do not know where the manufacturer's recommended lifting points are on a vehicle, you must find out before you raise it.** **ALI provides guides** that will assist you: *Vehicle Lifting Points for Frame Engaging Lifts* shows the lifting points for hundreds of vehicles. *Lifting It Right* includes information about how to raise vehicles correctly. You may also contact the vehicle manufacturer for this information.

Components

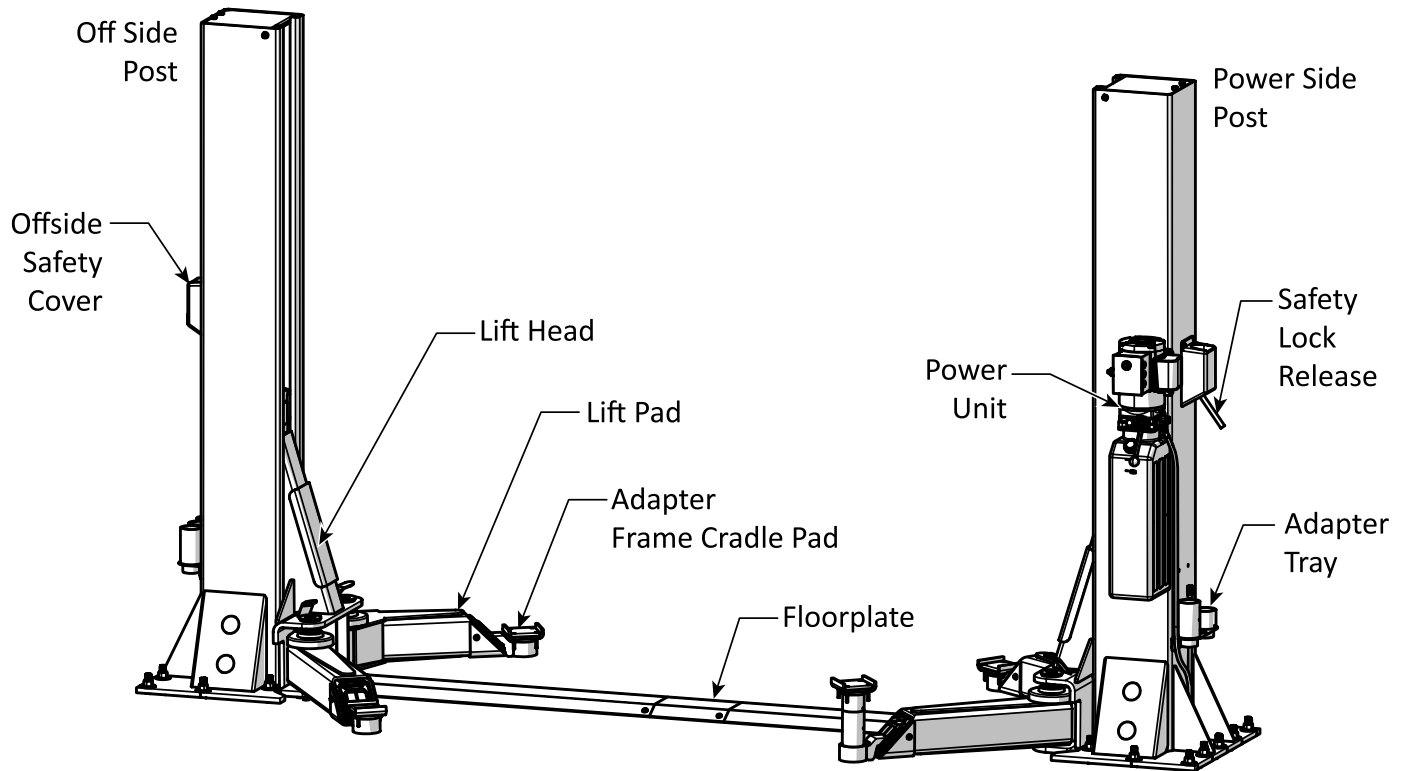

10AP-SRT and 12AP-SRT Lift components include:

- **Power Side Post** — The power side Post supports the power unit, the safety lock release handle, and the Lowering Handle (on the power unit).
- **Off Side Post** — The Lift post opposite the power unit.
- **Power Unit** — Provides hydraulic fluid pressure to the Lift and connects to an appropriate electrical power source. Includes the Up Button, the Lowering Handle, and the hydraulic fluid reservoir.
- **Safety Lock Release Handle** — Located on the power post above the power unit, it disengages the safety locks allowing the Lift to lower.
- **Safety Covers** — Protect the safety lock mechanism on the posts.
- **Floor Plates** — Covers and protects the hydraulic hoses, equalizing cables, and safety lock cable routed between the Lift posts.
- **Lift Heads** — Sometimes called carriages. Lift Heads move up and down in the Posts. They connect to the lift arms, so when the lift heads rise, so do the lift arms.
- **Lift Arms** — Extendable steel arms that attach to the lift heads.
- **Adapter Lift Pads** — Pads that contact the lifting points on the underside of the vehicles you raise. Four cradle adapters are included with the 12AP-SRT and are well-suited for raising trucks and SUVs. Four screw lift pads are included with the 10AP-SRT. Additional adapters are available separately and include height adapters, pinch weld pads and screw pad adapters.
- **Height Adapter Trays** — Attach to the bottom of the posts, used for holding the spare adapters when not in use.
- **Safety Locks** — Hold the lift heads up when engaged. Multiple safety lock heights let you select the best one for your needs. Once engaged on its safety locks, the lift heads stay up, even if the Lift loses power. Only leave your Lift fully lowered or engaged on safety locks.

Specifications 10AP-SRT

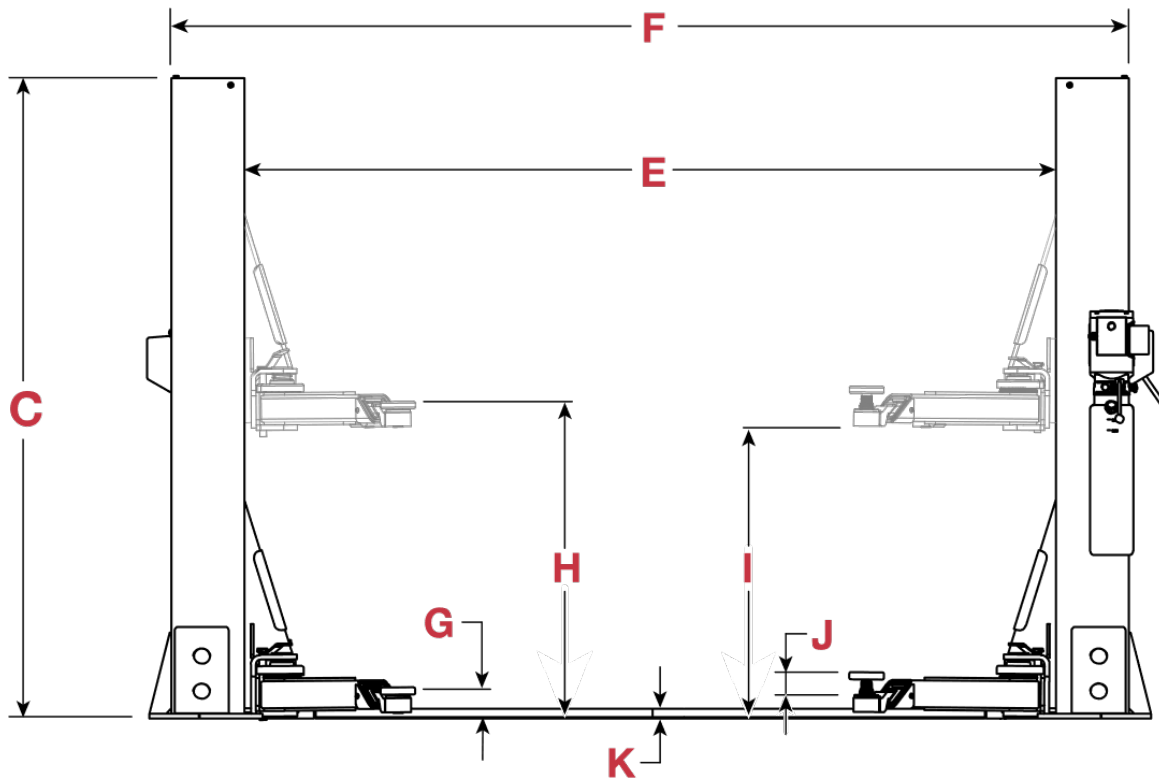
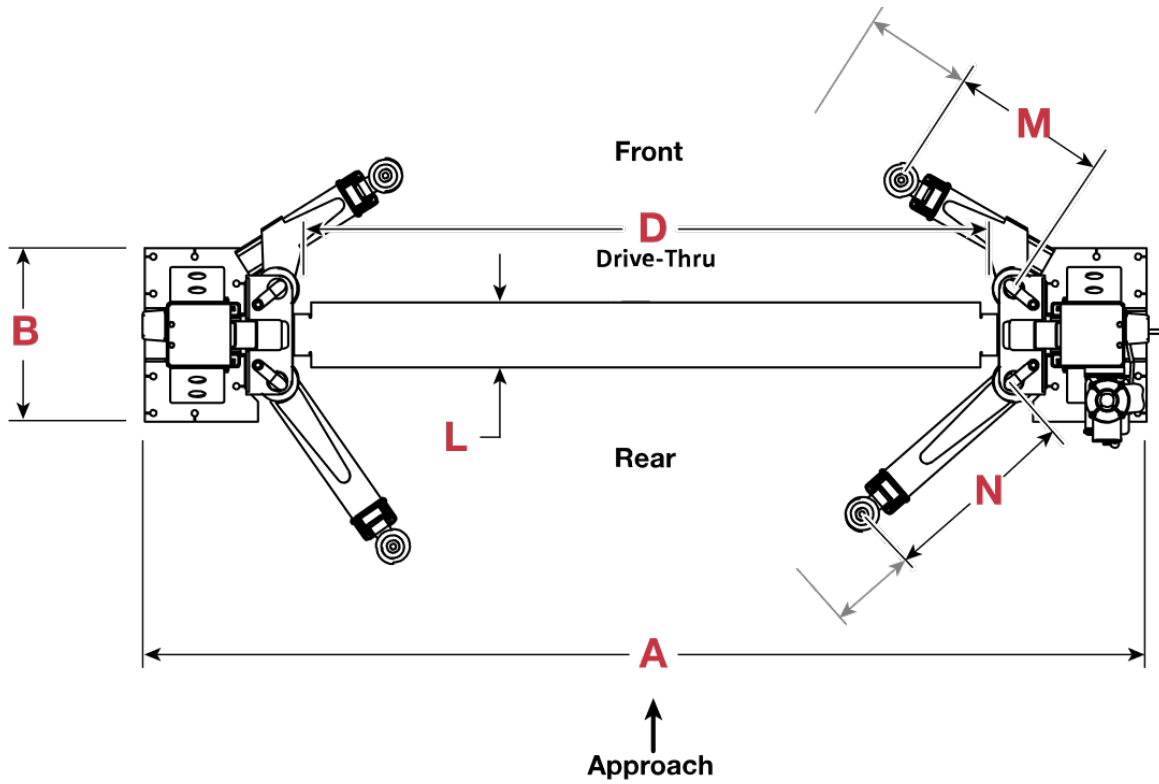

10AP-SRT

Specification	Value
Lifting Capacity	10,000 lbs. (4,536 kg)
Maximum Capacity – Front Axle	5,000 lbs. (2,268 kg)
Maximum Capacity – Rear Axle	5,000 lbs. (2,268 kg)
Maximum Capacity per Lift Arm	2,500 lbs. (1,134 kg)
A – Width Overall	139 in. (3,529 mm)
B – Base Plate Width	25.25 in. (642 mm)
C – Post Height	93.5 in. (2,377 mm)
D – Drive-Thru	94 in. (2,389 mm)
E – Inside Posts	111.25 in. (2,825 mm)
F – Outside Posts	132.5 in. (3,365 mm)
G – Minimum Height w/Pad	4.75 in. (122 mm)
H – Maximum Lifting Height ¹	46.25 in. (1,185 mm)
I – Maximum Rise ²	42.5 in. (1,081 mm)
J – Maximum Pad Adjustment	2.25 in. (55 mm)
K – Floor Plate Height	1.4 in. (36 mm)
L – Floor Plate Width	9.5 in. (240 mm)
M – Front Arm Reach (min. – max.) ¹	22.5 in. to 47.5 in. (562 mm to 1,205 mm)
N – Front Arm Reach (min. – max.) ³	29.5 in. to 57 in. (747 mm to 1,446 mm)
Safety Lock Positions	8 Positions positioned every 3.75 in. (95 mm)
Operating Hydraulic Pressure under Max. Load	2,170 psi
Hydraulic Fluid Required	3.6 gallons (13.6 Liters)
Standard Motor ⁴	208-240 VAC, 50/60 Hz, 1 Phase, Approx. 11 Amps
Time to Full Rise	≈45 seconds
Sound	<43dB

¹ Max. Lifting Height w/Pad is the max. height while not engaged on a Safety Lock and without adjustment or adapter(s).

² Maximum Rise is the maximum lifting height not engaged on the Safety Lock.

³ Lift Arms measured from the Lift Arm pivot center to the Lift Pad Pin center.

⁴ Special voltages available upon request.

Specifications subject to change without notice.

Specifications 12AP-SRT

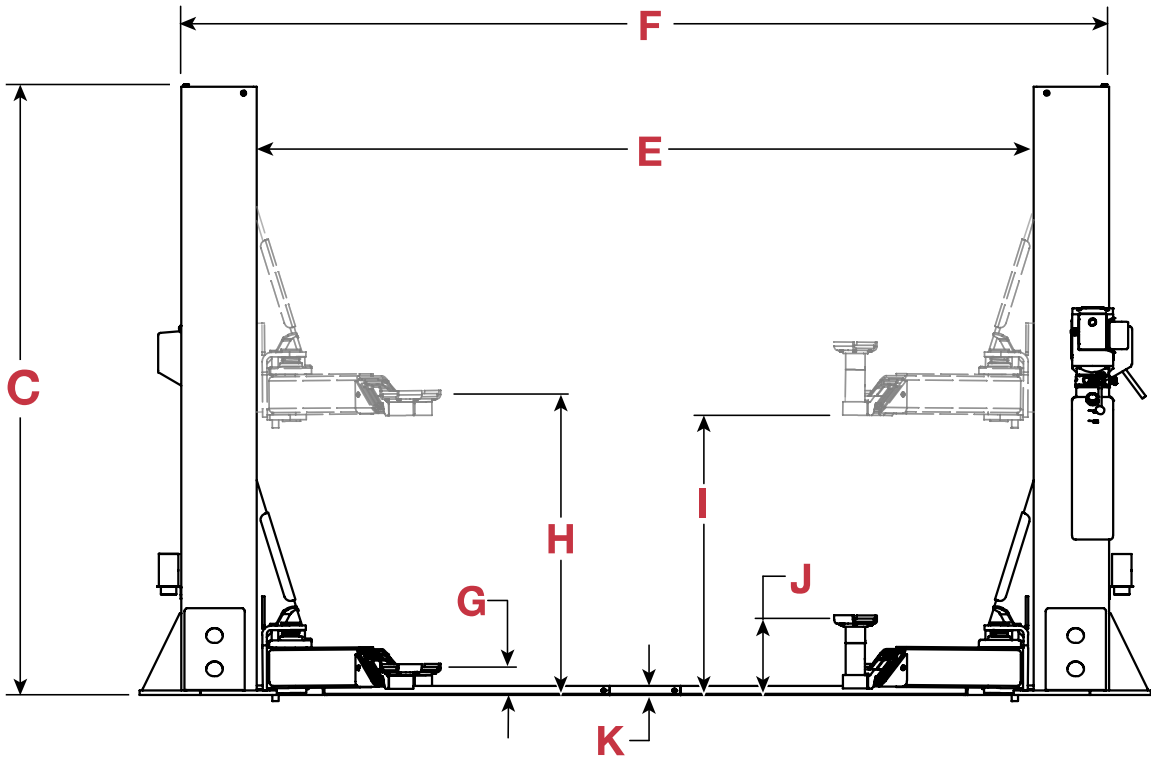
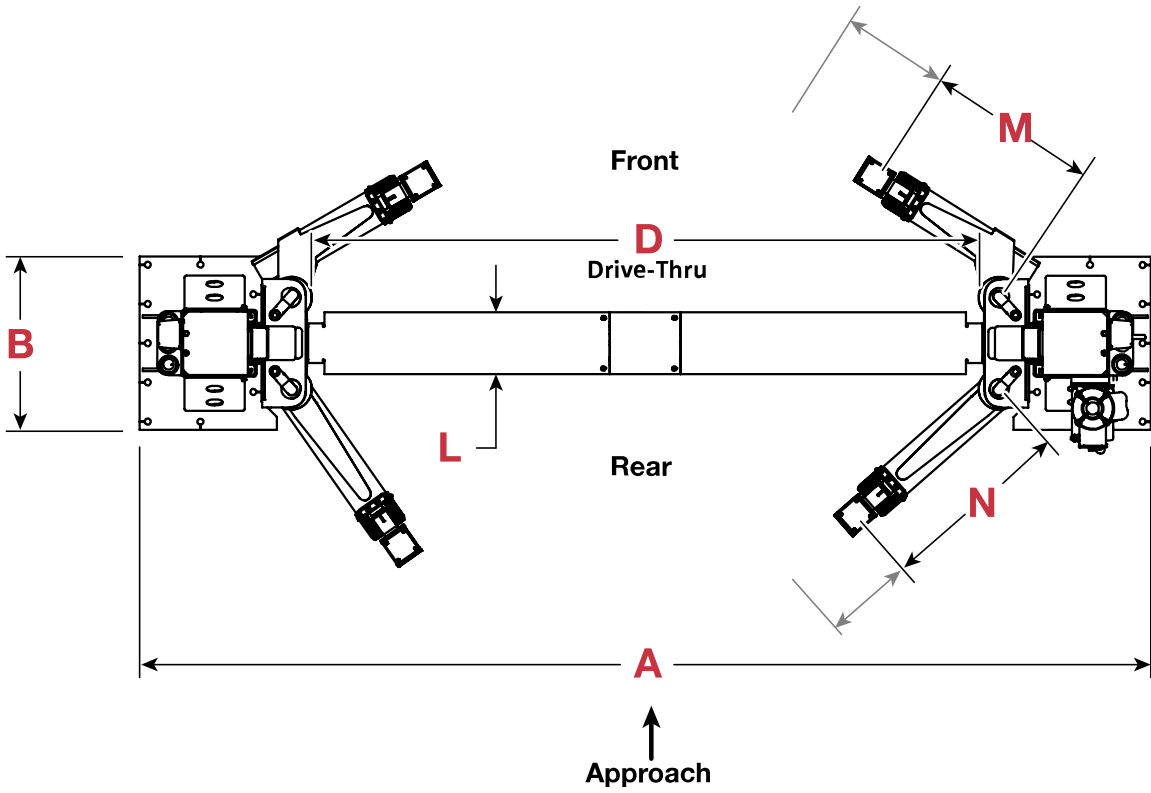

12AP-SRT

Specification	Value
Lifting Capacity	12,000 lbs. (5,443 kg)
Maximum Capacity – Front Axle	6,000 lbs. (2,721.5 kg)
Maximum Capacity – Rear Axle	6,000 lbs. (2,721.5 kg)
Maximum Capacity per Lift Arm	3,000 lbs. (1,360 kg)
A – Width Overall	155 in. (3,937 mm)
B – Base Plate Width	26.5 in. (674 mm)
C – Post Height	93.5 in. (2,376 mm)
D – Drive-Thru	102.25 in. (2,600 mm)
E – Inside Posts	119.25 in. (3,026 mm)
F – Outside Posts	142.25 in. (3,612 mm)
G – Minimum Height w/Pad	5 in. (128 mm)
H – Maximum Lifting Height w/Pad ¹	46.25 in. (1,173.5 mm)
I – Maximum Rise ²	43 in. (1,092 mm)
J – Max. Pad Adjustment with Adapters ³	12 in. 306 mm
K – Floor Plate Height	1.5 in. (36 mm)
L – Floor Plate Width	9.5 in. (240 mm)
M – Front Arm Reach (min. – max.) ⁴	26 in. to 55.25 in. (659 mm to 1,403 mm)
N – Rear Arm Reach (min. – max.) ⁴	29.25 in. to 60 in. (745 mm to 1,525 mm)
Safety Lock Positions	8 Positions positioned every 3.75 in. (95 mm)
Operating Hydraulic Pressure under Max. Load	2,493 psi
Hydraulic Fluid Required	3.6 gallons (13.6 Liters)
Standard Motor ⁵	208-230 VAC, 50/60 Hz, 1 Phase, 5 HP, 23 Amps
Time to Full Rise	≈ 68 seconds
Sound	<43dB

¹ Max. Lifting Height w/Pad is the max. height while not engaged on a Safety Lock and without adapter(s).

² Maximum Rise is the maximum lifting height not engaged on the Safety Lock.

³ One tall 4.9 in. (125 mm) and one medium adapter 2.5 in. (63 mm).

⁴ Lift Arms measured from the Lift Arm pivot center to the Lift Pad Pin center.

⁵ Special voltages available upon request.

Specifications subject to change without notice.

Installation Checklist

Following are the steps required to install the Lift; perform them in this order.

- 1. Review the Safety Rules and information.
- 2. Plan for the Electrical work.
- 3. Make sure you have the necessary Tools.
- 4. Review the Installation Orientation.
- 5. Review Clearances around and above the Lift.
- 6. Select the Installation Location.
- 7. Create Chalk Line Guides for the Posts.
- 8. Install the Equalizing Cables.
- 9. Anchor the Posts.
- 10. Install the Safety Lock Assemblies.
- 11. Route and Connect the Safety Lock Cable.
- 12. Read Hydraulic Fluid Contamination.
- 13. Read the Hydraulic System Warnings.
- 14. Read About Thread Sealants.
- 15. Route and Install the hydraulic hoses.
- 16. Mount the Power Unit (*do not connect to power*).
- 17. Connect the Hydraulic Hose to the Power Unit.
- 18. Install the Lift Arms.
- 19. Verify the Cylinder Clamps are positioned at the top of the lift head and secured on **both** cylinders!
- 20. Contact the Electrician.
- 21. Connect the Power Unit (**Electrician required**).
- 22. Install the Power Disconnect Switch (**Electrician required**).
- 23. Perform the Final Leveling.
- 24. Install the Safety Covers.
- 25. Lubricate the Lift.
- 26. Install the Floorplate.
- 27. Perform an Operational Test.
- 28. Review the Final Checklist.
- 29. Leave the manual with the Owner/Operator.

Installation

The installation process includes multiple steps. Perform them in the order listed.

 **WARNING** Use only the factory-supplied parts shipped with your Lift. If you use attachments, accessories, or configuration modifying components that are in the path and/or affect the operation of the equipment, affect the equipment's electrical listing, or affect the intended vehicle accommodation, and if they are not certified for use with this Lift, then you void the warranty of the Lift as well as compromising the safety of everyone who sets up or uses the Lift. If you are missing parts, visit [BendPak.com/Support](https://www.bendpak.com/Support), email support@bendpak.com or contact BendPak technical support by phone at **(800) 253-2363**, option 7 then 4. Online chat is also available at www.bendpak.com click the chat icon. 

Reviewing the Safety Rules

When installing a Lift, your safety depends on proper training and thoughtful operation.

 **WARNING** Do not install this equipment unless you have automotive lift installation training. Always use proper lifting tools, such as a Forklift or Shop Crane, to raise heavy components. Do not install this equipment without reading and understanding this Manual and the Labels on the unit.

Only fully trained personnel should be involved in installing this equipment. Always pay attention. Use appropriate tools and lifting equipment. Stay clear of moving parts.

 **WARNING** You must always wear appropriate protective equipment during installation: leather gloves, steel-toed work boots, eye protection, back belts, and hearing protection.

Plan for Electrical Work

A licensed Electrician will be required at some point during the installation.

 **DANGER** A licensed Electrician must perform all wiring. Verify all electrical work conforms to all applicable local, state, and federal codes, rules, and regulations.

Notify your Electrician in advance, so they arrive prepared with the items required to connect to the facility's power system or an appropriate power cord with plug for connecting to an appropriate power source, a Power Disconnect Switch, and a Thermal Disconnect *if required by local electrical code*. These items are *not* supplied with the Lift.

The Electrician is required to:

- **Connect to facility power.** The power unit is delivered with a pigtail for wiring to a power source. Have your Electrician connect a power cord with plug to the electrical junction box on the Lift (for connection to a power outlet) or have them wire it directly into the electrical system at the Lift location.

Note that *installing* the power unit and *connecting* the power unit to a power source are separate procedures and are done at different times in the installation process. You do **not** need an Electrician to *install* the power unit, but an Electrician is **required** to *connect* the power unit to the power source.

-
- **Install a Power Disconnect Switch.** A Power Disconnect Switch is used to shut down the Lift in the event of an electrical circuit fault, emergency, or when the Lift is being serviced. This switch is not provided with the Lift. Refer to [Installing a Power Disconnect Switch](#) for more information.
 - **Install a Thermal Disconnect.** The Power Unit is not thermally protected. In accordance with NEC 430, UL 201, and CSA C22.2 No. 68, intermittent duty motors are not required to include thermal protection. Local electrical codes may vary, and other requirements may exist that the installing electrician will address, if required.

Gathering Your Tools

You may need some or all of the following tools:

- Rotary hammer drill (or similar)
- 3/4 inch carbide bit (conforming to ANSI B212.15)
- Hammer
- Four-foot level
- Open-end wrench set, SAE, and metric
- Socket and ratchet set, SAE, and metric
- Hex key wrench set
- Crescent and pipe wrenches
- Torque wrench
- Crowbar
- Chalk line
- Medium-sized flat screwdriver
- Tape measure, 25 feet or more
- Needle-nose pliers
- Forklift or Shop Crane
- Two 12-foot ladders
- Two sawhorses
- Red and white lithium grease

Reviewing the Installation Orientation

Keep these factors in mind when deciding how to orient the Lift:

- Determine which direction vehicles will be driving onto the Lift; this is the **Approach**.
 - In most cases, there is a driveway on one side and a wall on the other side. The driveway is your Approach. This makes the wall side the Front of the Lift and the driveway side the Rear of the Lift.
 - If both sides are open, decide which way vehicles will be driving onto the Lift. This is the Approach.
- While the power unit **must** be installed on the power side post, that power side Post may be mounted on either side of the Lift. You can identify the power side Post by the mounting bracket to which the power unit attaches. Refer to the figures below.

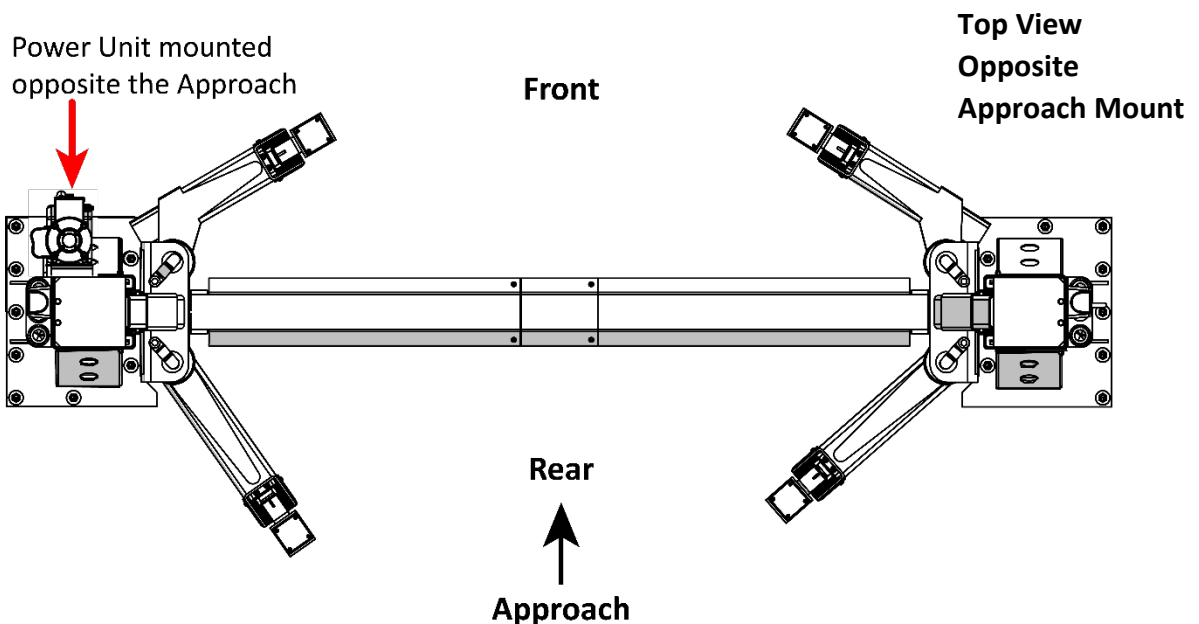
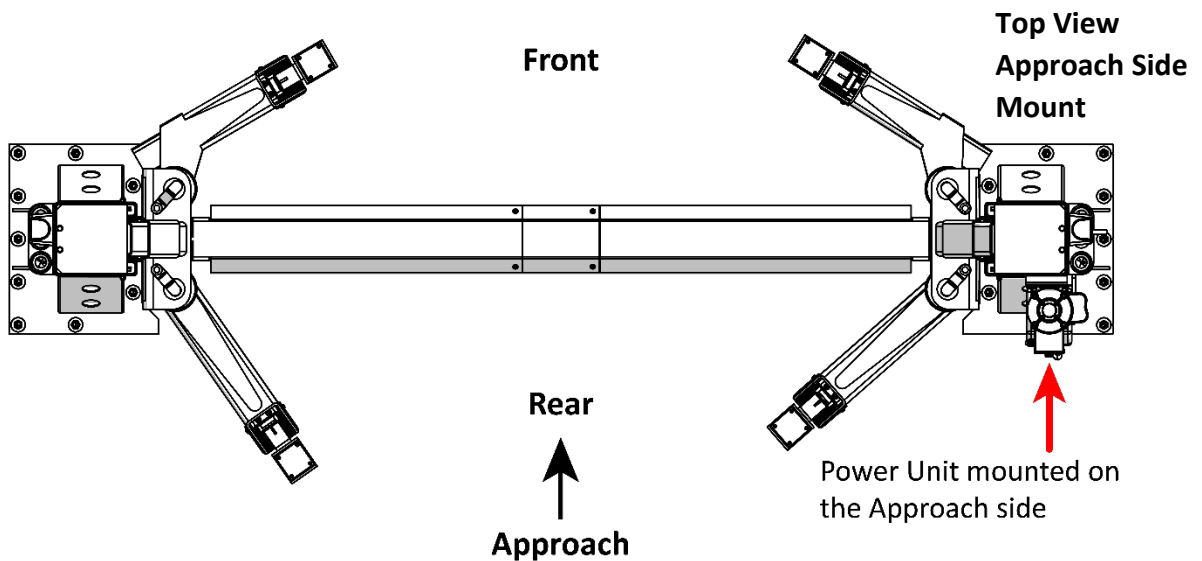

Review the Clearances Around and Above the Lift

Clear space around and above the Lift is **required** for safety. Figures below are not to scale.

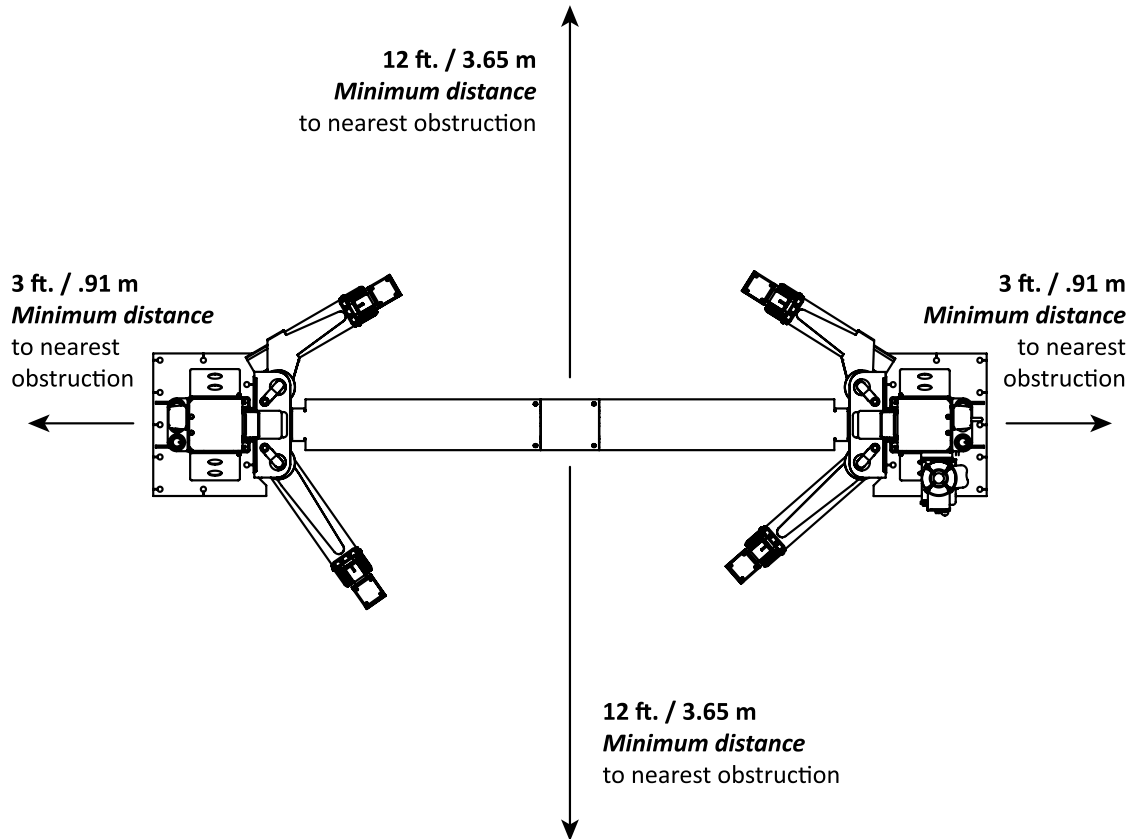

Additional distance is required for vehicles to be driven onto and off the Lift.

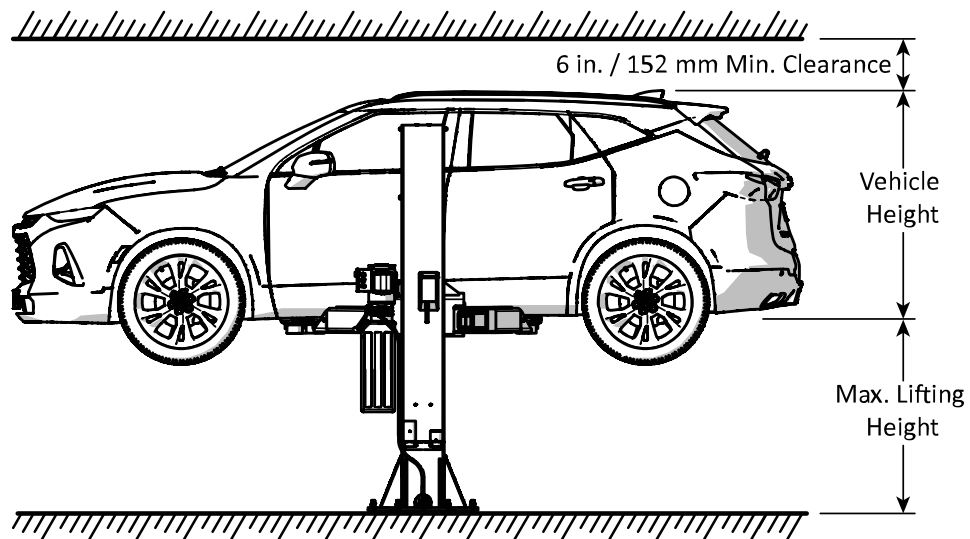

Selecting a Location

 **DANGER** **Risk of explosion.** This equipment has internal arcing components and should **not** be exposed to flammable vapors. The power unit's Motor should not be located in a recessed area or below floor level. Never expose the motor to rain or other damp environments; damage to the motor caused by water is not covered by the warranty.

- **Architectural plans.** Consult the architectural plans for the desired location. Make sure there are no contradictions between what you want to do and what the plans show.
- **Available space.** Make sure there is enough space for the Lift: front, back, sides, and **above**. Refer to **Specifications** for exact measurements.
- **Overhead obstructions.** Check for overhead obstructions such as building supports, heaters, lights, electrical lines, low ceilings, and so on.
- **Power.** An appropriate electrical power source for the Lift's power unit is required.
- **Outdoor installations. *Outdoor installation is prohibited.*** Your Lift is approved for **indoor installation and use only**.
- Do **not** install the Lift on any surface other than steel reinforced concrete conforming to the minimum compressive strength, aging, reinforcement, and thickness stated in these requirements.
- **Never** install the Lift over a concrete expansion joint.
- All Anchors **must** be a minimum of 6 in. (152 mm) away from any expansion seams, control joints or other inconsistencies in the concrete.
- **Never** install the Lift on hand-mixed concrete.
- Do **not** install the Lift on a secondary floor level or on any ground floor with a basement beneath without written authorization from the building Architect and prior approval of BendPak Inc.
- **Never** drill or cut into a post-tensioned slab. Seek qualified personnel to identify cable locations prior to cutting or drilling

 **WARNING** Installing your Lift on a surface with more than three degrees of slope could lead to injury or even death. Only install your Lift on a level floor (defined as no more than 3/8 of an inch difference over the installation area). If your floor is not level, consider making the floor level or using a different location.

- **Concrete specifications.** Verify the concrete depth for the Lift being installed:
 - **10AP-SRT** 4.25 in. (108 mm) min.
 - **12AP-SRT** 6.5 in. (165 mm) min.

Concrete must be steel reinforced, with 3,000 PSI compressive force, and cured for a minimum of 28 days. Do not install the Lift on cracked or defective concrete. Anchor Bolts must be more than 6 inches from cracks in the concrete or from an expansion seam or wall.

 **CAUTION** BendPak Lifts are supplied with installation instructions and concrete anchors that meet the criteria set by the latest version of the American National Standard "Automotive Lifts – Safety Requirements for Construction, Testing, and Validation," ANSI/ALI ALCTV. Consult with an expert for any special regional structural and/or seismic anchoring requirements specified by any other agencies and/or codes such as the Uniform Building Code (UBC) and/or International Building Code (IBC).

Determine if the floor is a post-tension slab. If confirmed, contact the building architect **before** drilling. Ground penetrating radar may help locate post-tensioned steel. The local department of

building and safety may also have building records to indicate the slab type, reinforcement, and concrete specifications.

⚠ WARNING Cutting through a tensioned cable can result in injury or death. Do not drill into a post-tension slab unless the building architect confirms you are **not** going to hit tensioned steel, or you have located it using ground penetrating radar. **If a colored sheath comes up during drilling, stop drilling immediately.**

- **Unloading the components.** The Lift includes several heavy components. Unload the Lift components as close to the installation location as possible.

⚠ WARNING Some Lift components are very heavy; if handled incorrectly, they can damage materials like tile, sandstone, and brick. Try to handle the Lift components just twice: once when delivered and once when moved into position. You must have a Forklift or Shop Crane to move some of the Lift components into position. **Use care when moving Lift components.**

Create Chalk Line Guides

Create Chalk Line Guides on the ground for the two posts prior to moving them into position. Use the Width Overall value **for the Lift model** to determine where to place the chalk line guides. The Width Overall value is defined as the distance from the back of one base plate to the back of the other base plate. The figure below details the chalk line guides.

Lift Model	Width Overall
10AP-SRT	139 in. (3,529 mm)
12AP-SRT	155 in. (3,937 mm)

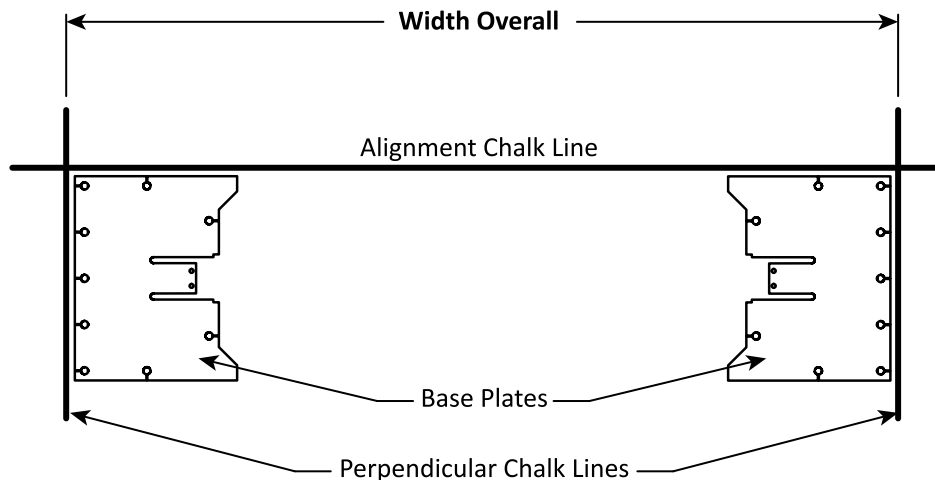

To create the Chalk Line Guides:

1. Decide the Lift location.
2. Create an Alignment Chalk Line at the Front of the Lift. Make the Alignment Chalk Line longer than the Width Overall setting for your Lift model. Reference the table above.
3. Create two Perpendicular Chalk Lines at 90° angles to the Alignment Chalk Lines at the Width Overall distance for the lift you are installing. The Lift base plates will stand in the corners created by the chalk line guides, as shown in the figure above.

Install the Equalizing Cables and Position the Posts

⚠ CAUTION Always wear gloves when handling the equalizing cables.

It is much easier to put the equalizing cables into position **before** standing up the posts.

The equalizing cables keep the lift heads synchronized. They prevent one lift head from lowering or rising faster than the other. When the equalizing cables are fully routed, they are mirror images of each other. Refer to the figure below.

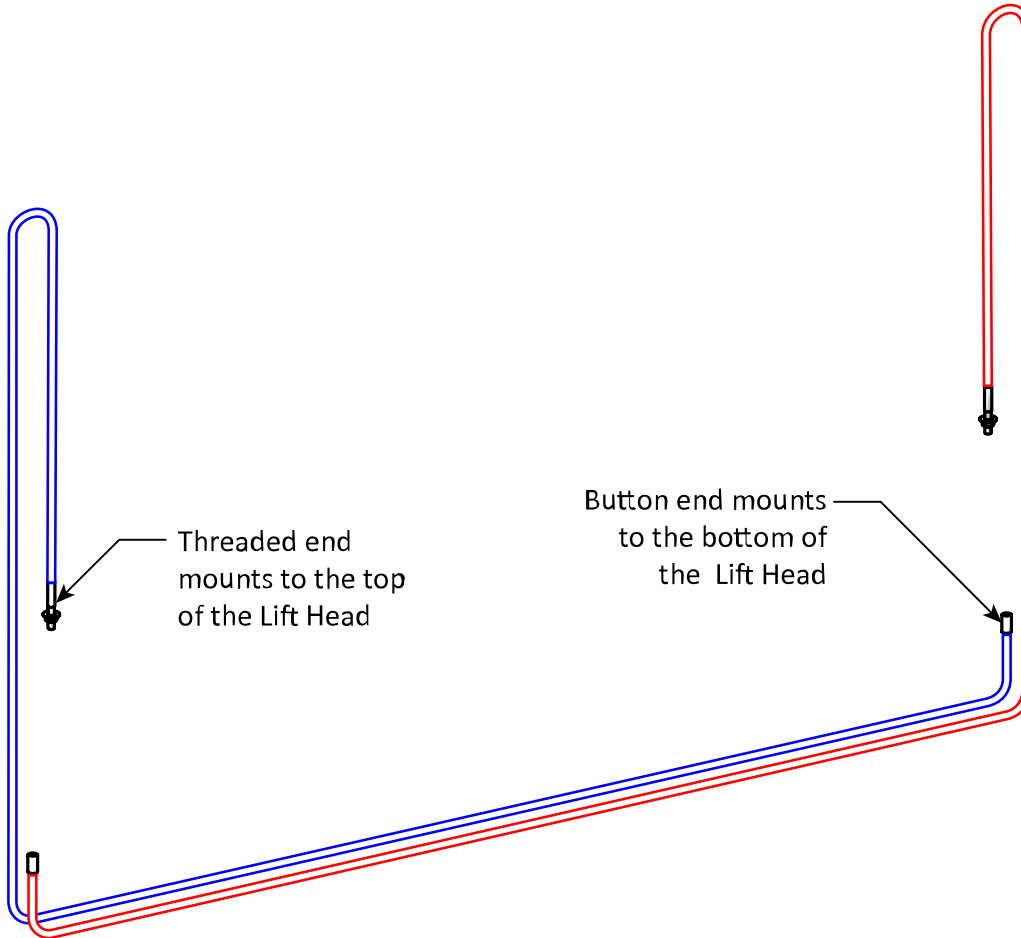

⚠ CAUTION BendPak recommends wearing leather gloves while handling the equalizing cables.

To put the Equalizing Cables into position:

1. Using a forklift or equivalent, move the posts near the Chalk Lines.
2. Place both posts either flat on the ground or with their tops elevated on a sawhorse pair or similar; the insides of the posts need to be accessible, facing up.
3. Slide the lift heads away from the base of both posts by at least 24 inches (610 mm), to provide some space to work.

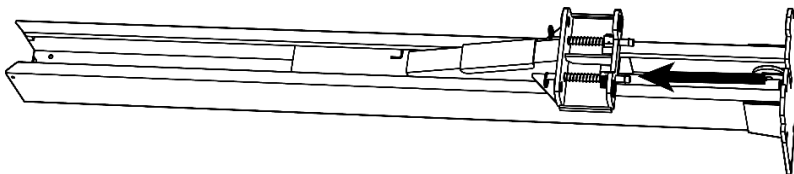

CAUTION Read **About Thread Sealants** before installing the nipples as described below.

4. On the **Power Side Post's** lift arm side, remove the shipping plug from the Lift cylinder port, then install the short nipple (5550147), making sure to use thread sealant on the NPT threads only. Refer to the figure below.
5. On the **Power Side Post's** back side, remove the shipping plug from the cylinder port, then install the long nipple (5550228), making sure to use thread sealant on NPT threads only. Refer to the figure below.

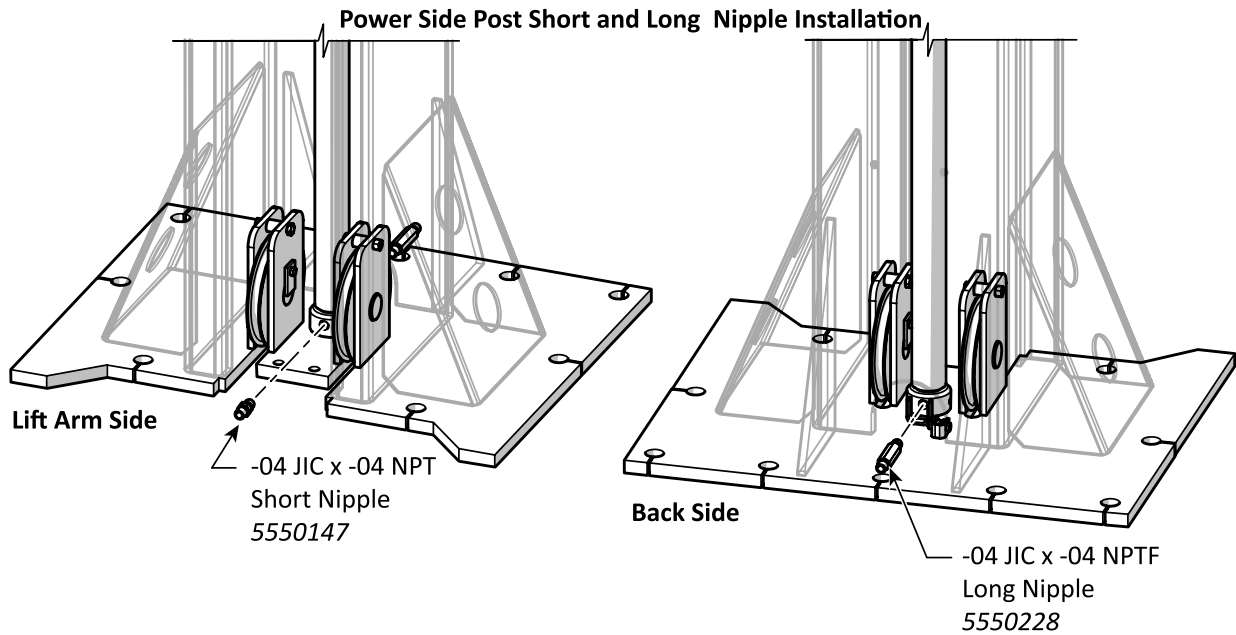

6. On the **Off Side Post**, remove the shipping plug from the lift cylinder port, then install the short nipple (5550147), making sure to use thread sealant on the NPT threads only. Refer to the figure below.

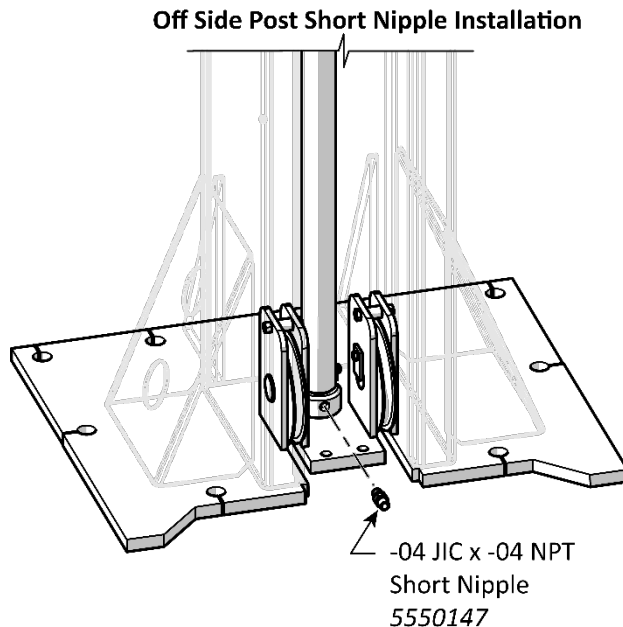

7. Remove **both** post sheaves from the bottom of **both** posts. Keep the cable sheaves, pins, spacers, and fasteners in a container to prevent loss; they will be re-installed soon. Refer to the figure below

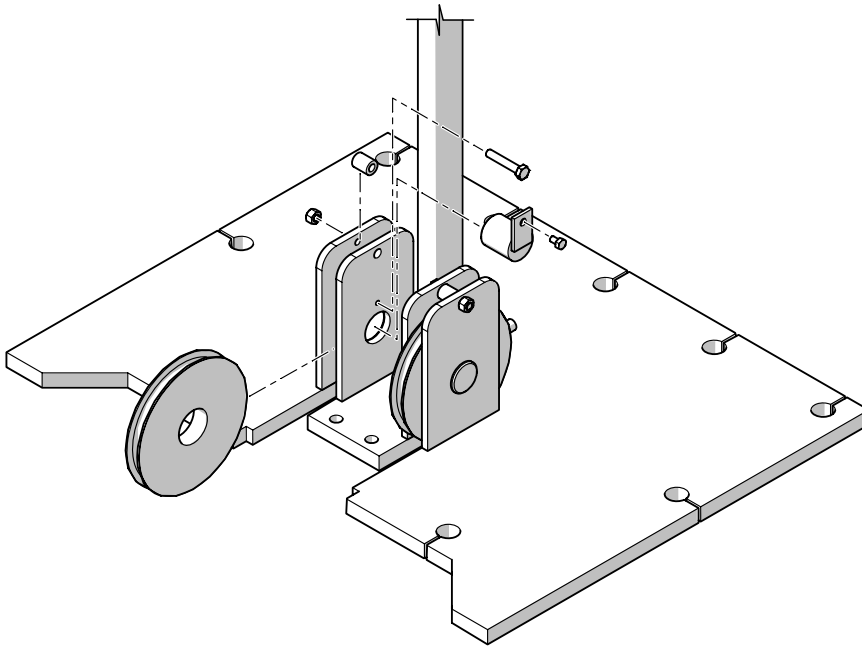

8. Locate the two equalizing cables.

Lift Model	Part Number	Description
10AP-SRT	5595911	Cable Assembly Ø10 x 7,270 mm
12AP-SRT	5595757	Cable Assembly Ø12 x 7,332 mm

Button End attaches at the bottom of the Lift Head

Threaded End attaches at the top of the Lift Head

9. Secure the Button End of the equalizing cable on the bottom plate inside each lift head. Refer to the cross-section view of the off side post on the next page.

Cross Section View - Lift Head in the *Up* Position

CAUTION Failure to secure the Equalizing Cable Button End may result in Lift failure or malfunction.

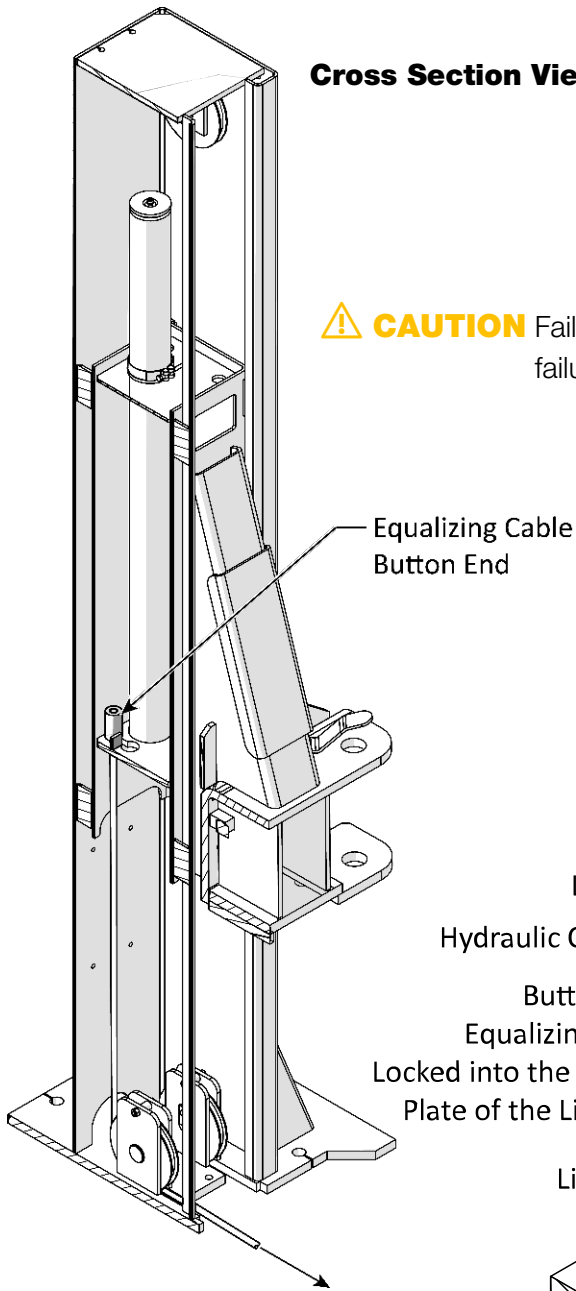

Cross Section View - Lift Head in the *Down* Position

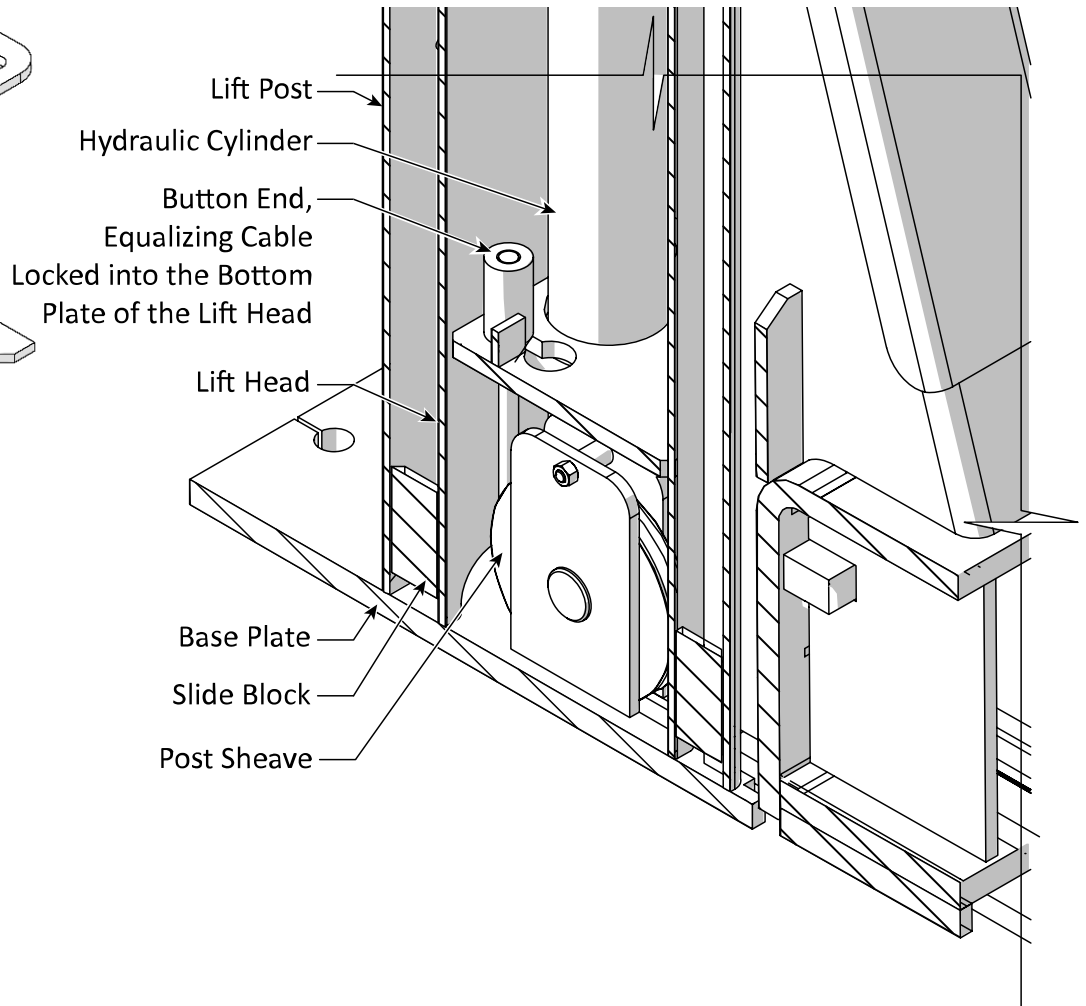

Important: It can be difficult to get the button end into the slot, as it may be hard to reach the lock plate. You may want to use a metal rod or a long tool to push the button end into the slot.



Tip If you are having problems getting the button end into the slot, try pushing the button end past the lock plate. Then move the equalizing cable around to get the cable into the slot. Once the cable is in the slot, pull on the other end of the cable to slide the button end into the slot. Route the threaded end of the equalizing cable *downwards* to exit the Lift post.

10. Re-Install the post sheave for this cable using the fasteners and pin removed earlier.



Tip Use a pair of vise grips attached to the cable at the top of the lift head to keep the tension on the cable and prevent the button end of the cable from working its way out of the lock.

11. Coil the cable and secure with wire or tape to keep it out of the way

12. Repeat steps 9 through 12 on the remaining Lift post.

13. Remove the tape or wire securing one of the equalizing cables.

14. Route the threaded end of that cable to the bottom of the opposite Lift post and up through the post, through the Lift head to the top of the Lift post. Allow the threaded end of the cable to hang loosely out the top of the Lift post.

15. Reinstall the bottom post sheave for this cable using the fasteners and pin removed earlier.

16. Retrieve the top plate and pulley assembly then thread the cable around the top sheave running the cable back down to the top of the lift head. Refer to the figure below to assemble the top plate.

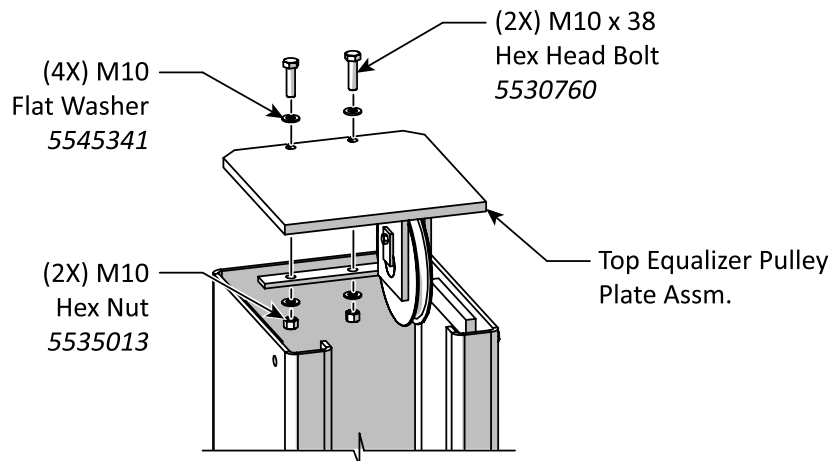

17. Insert the threaded end of the cable into the top of the lift head. Use the washer and hex nut to loosely secure the cable end to the lift head.

18. Repeat steps 14 through 18 with the cable on the opposite Lift post.

19. After the cables are in place. Reinstall all sheaves and pins that were removed.

20. Verify the pulley plate at the top of each post is secured.

21. Move both lift heads back down to the bottom of each post.

22. Stand up each post and move to the chalk lines previously made.

⚠ WARNING The Lift posts are heavy. Use appropriate lifting equipment and techniques to avoid severe injury. Always work with an assistant and wear appropriate protective equipment including steel-toed boots and leather gloves.

23. Verify the equalizing cables are not trapped under the posts. Completed equalizing cable routing should appear as pictured in the figure below. *posts removed for clarity.*

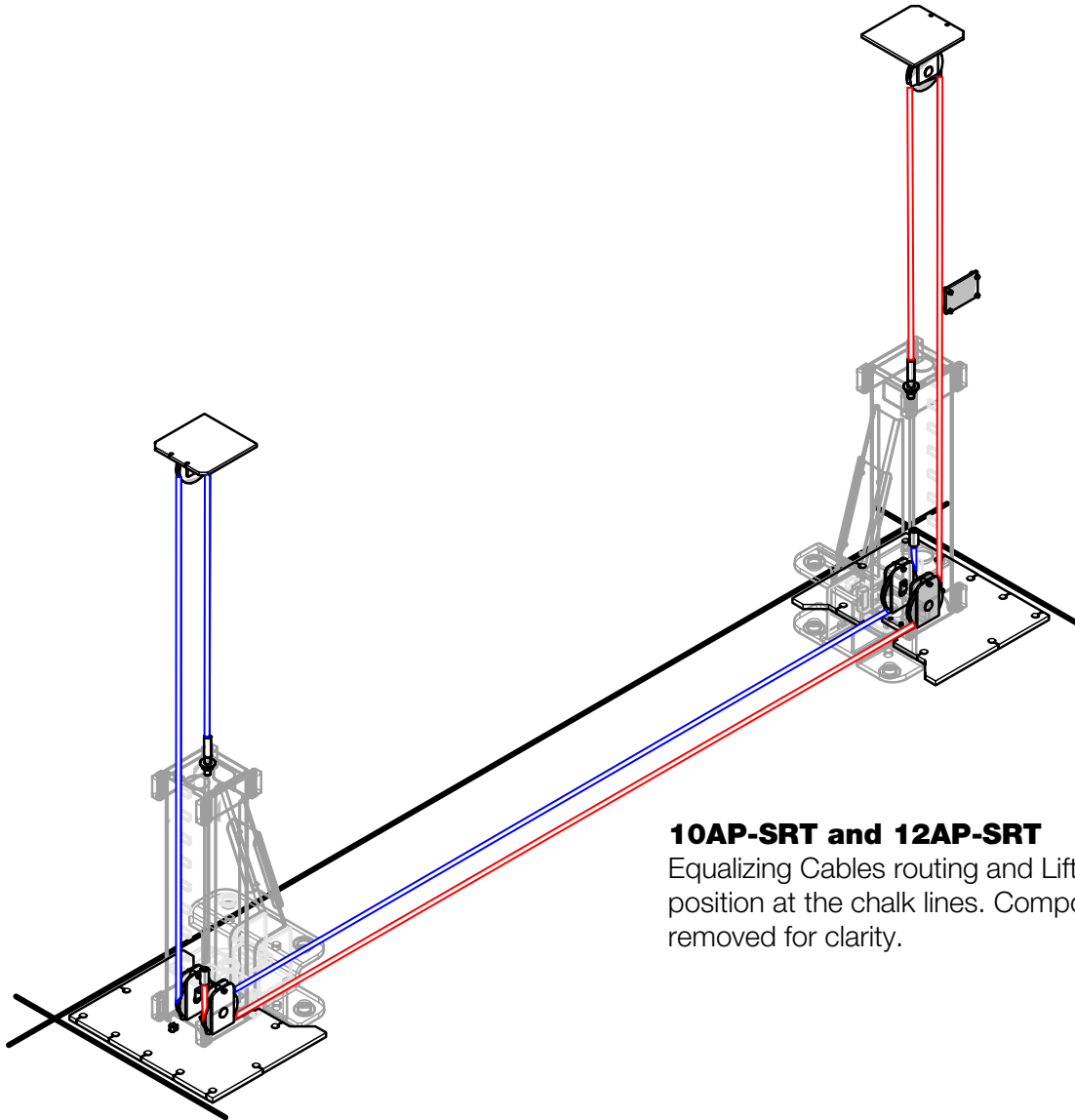

10AP-SRT and 12AP-SRT

Equalizing Cables routing and Lift posts in position at the chalk lines. Components removed for clarity.

24. Locate the two Double Threaded Rods, four M10 hex nuts, and flat washers in the Parts Box.
25. Install the rods and fasteners at the top of each Lift post, then tighten to 2-3 ft. lbs. of torque. Refer to the figure and table below.

Model	Part Number	Description
10AP-SRT	5746167	Dbl. Threaded Rod M10 x 275 mm
12AP-SRT	5746166	Dbl. Threaded Rod M10 x 295 mm

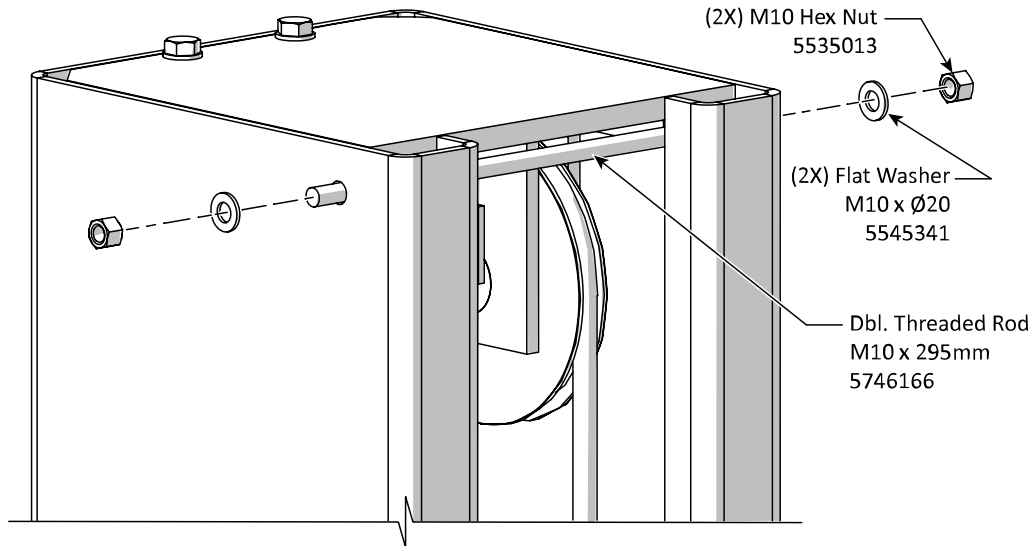

⚠ WARNING Do not operate the Lift without the double threaded rod in place. Failure to comply with these installation instructions can result in serious bodily injury and damage to the Lift.

Anchoring the Posts

⚠ DANGER Pay **special** attention when installing the posts. If done incorrectly, the Lift could fall over, potentially causing damage to the vehicle, the Lift, and injuring bystanders.

Concrete specifications are:

- **Depth:**
 - **10AP-SRT** 4.25 in. (108 mm) min.
 - **12AP-SRT** 6.5 in. (165 mm) min.
- **PSI:** 3,000 PSI, minimum
- **Cured:** 28 days, minimum

Anchor Bolt specifications are:

- **Length:** 6.3 inches (160 mm)
- **Diameter:** .75 inch (19 mm)
- **Anchor torque:** 85 – 95 ft. lbs.
- **Effective embedment:** 3.25 inches / (82.5 mm) or more

The concrete floor where the Lift will be installed must meet the following requirements:

- The floor must be a flat, concrete floor. It must be level; **do not install the Lift on a surface with more than three degrees of slope.**
- The concrete must be steel reinforced.
- Do not install the Lift on cracked or defective concrete.
- Verify the concrete floor is not a post-tension slab. In this case, contact the building architect before drilling. Using ground penetrating radar may help locate the tensioned cable.

⚠ WARNING Cutting through a post-tensioned cable can result in injury or death. Do not drill into a post-tension slab unless the building architect confirms you are **not** going to hit a tensioned cable, or they have been located using ground penetrating radar. **If a colored sheath comes up during drilling, stop drilling immediately.**

⚠ WARNING Your concrete and anchor bolts **must** meet these specifications. Only install your Lift on a concrete surface. If you install a Lift on asphalt or any other surface, or your concrete or anchor bolts do not meet these specifications, it could lead to product damage, vehicle damage, personal injury, or even loss of life.

BendPak Lifts are supplied with installation instructions and concrete fasteners meeting the criteria as prescribed by the latest version of the American National Standard, “Automotive Lifts – Safety Requirements for Construction, Testing, and Validation.”

⚠ WARNING Use only the ALI-certified anchor bolts delivered with your Lift. If you use components from a different source, you void your warranty and compromise the safety of everyone who installs or uses the Lift.

Lift buyers are responsible for conforming to all regional, structural, and seismic anchoring requirements specified by any other agencies and/or codes, such as the Uniform Building Code and/or International Building Code.

Effective Embedment is the location in the anchor hole where the expansion sleeve presses into the concrete. This is where the anchor bolts get their holding strength, the further down into the anchor hole, the greater the holding strength.

Nominal Embedment is how far down into the anchor hole the bottom of the anchor bolt is.

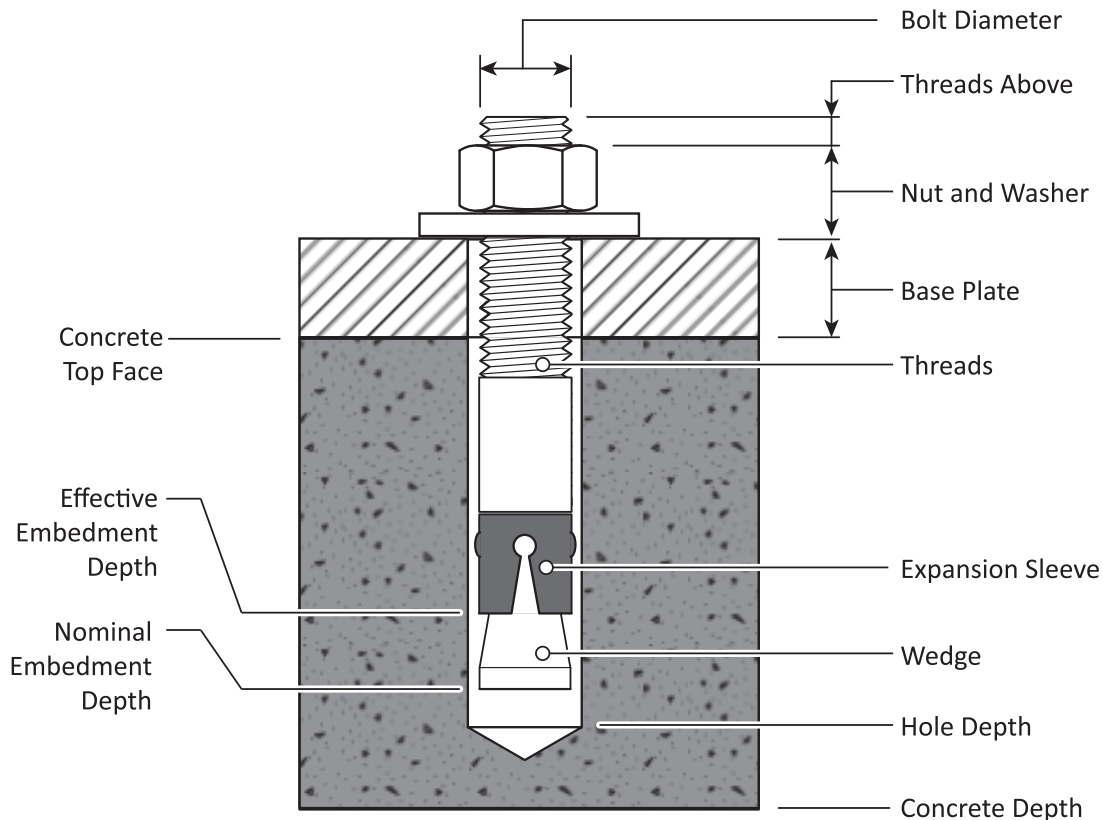

To anchor the Lift Posts:

1. Verify the posts are positioned at the chalk line guides created earlier.
2. Stand up each post, one at a time, and move it to the appropriate location.
3. Double check your measurements against the **Specifications** for the specific Lift model:

Verify the **Width Overall** distance from the back of one base plate to the back of the other base plate.

4. Using the base plates as guides, using a sharp masonry drill bit, drill each hole:
10AP-SRT: 4.25 inches (108 mm) deep minimum.
12AP-SRT: 6.5 inches (165 mm) deep minimum.

⚠ WARNING You must use the appropriate safety gear including safety glasses, dust masks, gloves, steel-toed work boots and heavy work clothes when anchoring the posts.

Important: The holding strength of an anchor bolt is partially based on the how cleanly the Expansion Sleeve presses against the concrete. If the hole is dirty or too wide, there is a reduction in holding strength.

Do not drill all the way through the concrete. Drilling completely through the slab could compromise the holding strength of the anchor bolts.

The diameter of the drill bit must be the same as the diameter of the anchor bolt. If you are using a $\frac{3}{4}$ inch diameter anchor bolt, use a $\frac{3}{4}$ inch diameter drill bit. Ensure the drill flutes are at least as long as the depth of the hole to effectively remove material as you drill.

Drill a pilot hole! Pilot holes allow straighter, cleaner drilling by removing the material directly from the center of the final drill. This reduces the amount of force required to keep the drill straight and perpendicular to the floor.

If the drill hits rebar embedded in the concrete and has not ruined the Anchor Hole by making it too big or out of round, switch to a rebar cutting drill bit. Slow the drill speed to avoid overheating the drill bit. Continue drilling until you are past the Rebar.

Do not rush. Pull the drill out of the hole frequently to remove debris and clear the opening.

5. Vacuum each hole clean. BendPak recommends using a Vacuum to get the hole very clean. Use a wire brush, hand pump, or compressed air to thoroughly clean each hole. Do not ream the hole. Do not make the hole any wider than the drill bit made it.

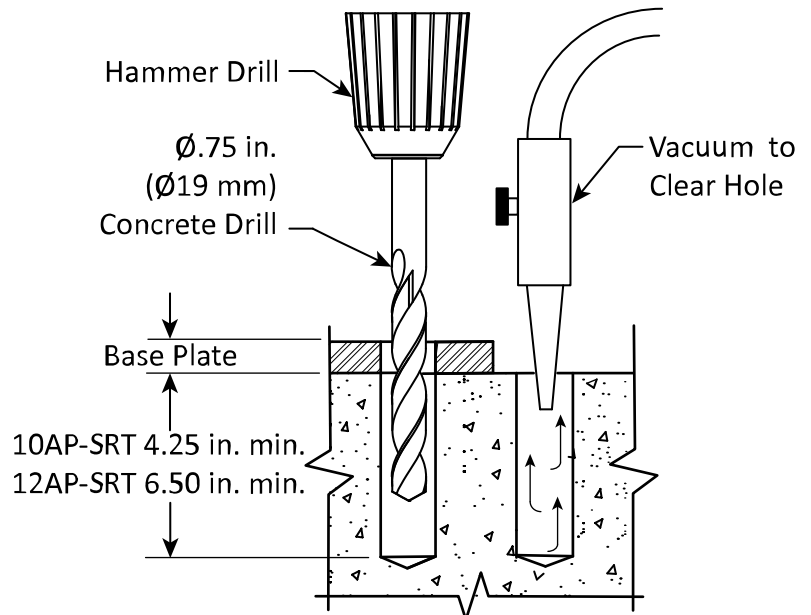

6. Make sure the washer and hex nut are in place, then insert the anchor bolt into the hole. The Expansion Sleeve of the anchor bolt may prevent the anchor bolt from passing through the hole in the base plate; this is normal. Use a hammer or mallet to gently tap the Expansion Sleeve through the base plate and into the hole. Even using a hammer or mallet, the anchor bolt should only go into the hole part of the way; this is normal. If the anchor bolt drops in with little or no resistance, the hole is too wide. Once past the hole in the base plate, the anchor bolt eventually stops progressing down into the hole as the Expansion Sleeve contacts the sides of the hole; this is normal.

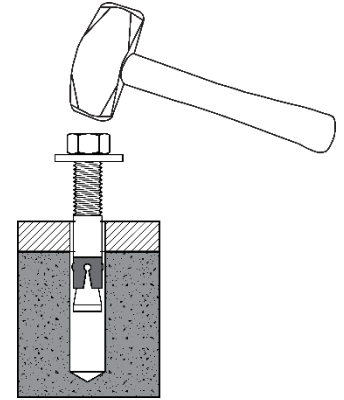

7. Hammer or mallet the anchor bolt the rest of the way down into the hole; stop when the washer is snug against the base plate.

8. Plumb each post. Install the required shims to bring the post to perpendicular.

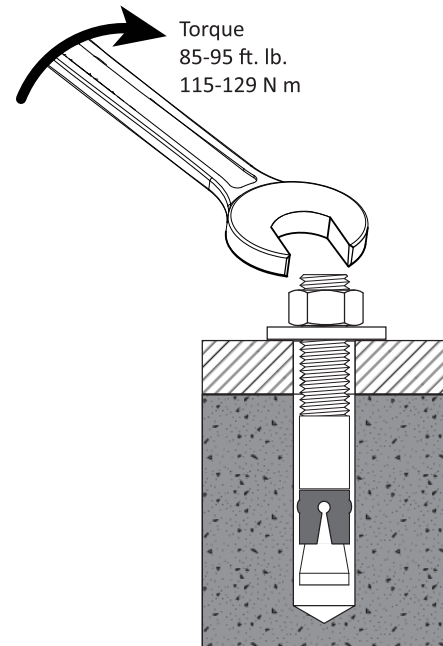
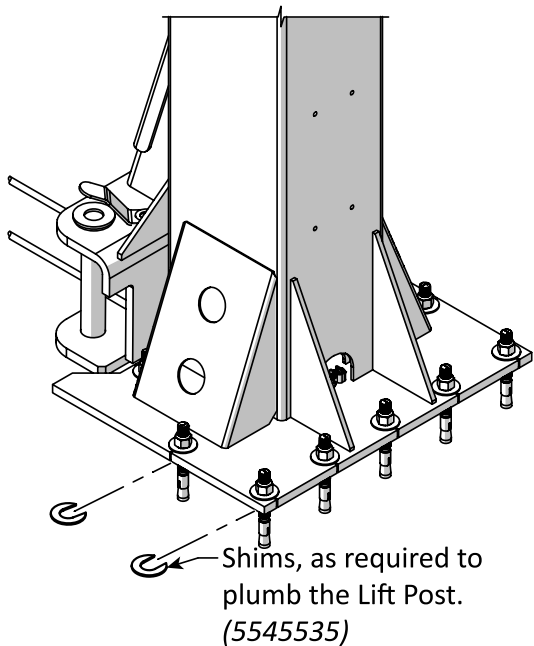

9. Wrench each hex nut **clockwise** to the recommended installation torque of 85 – 95 ft. lbs., using a Torque Wrench.

Important: Do **not** use an impact wrench to torque the anchor bolts.

Safety Lock Assemblies

The safety release handle is used to retract the safety locks and allow the Lift to lower. Both safety assemblies must be disengaged at the same time so that the lift arms lower together. The two safety lock assemblies are connected to each other via the safety lock cable.

To install the 10AP-SRT and 12AP-SRT Power Side Safety Lock and Release Handle:

1. Locate the Parts Box and retrieve the pivot holder, pivot pin, power side safety weldment, and fasteners. Assemble as detailed in the figures below. **Note the 10AP-SRT Safety Weldment has a different spring arrangement than the 12AP-SRT.**
2. Retrieve the safety handle weldment and fasteners from the parts box. Assemble as detailed in the figures below.

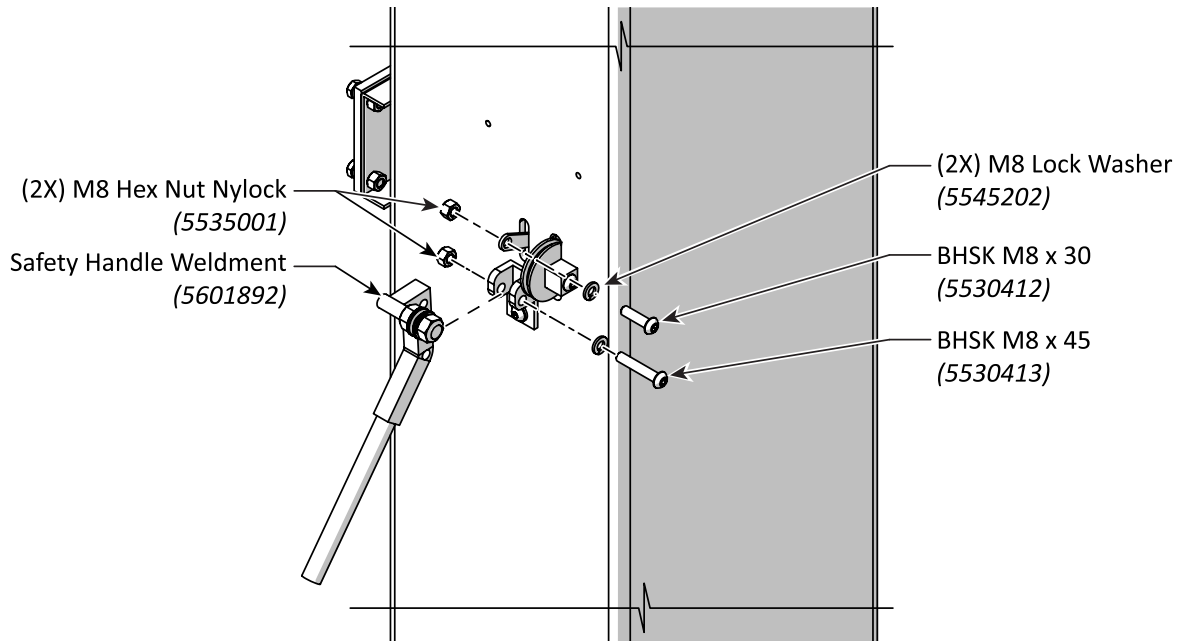
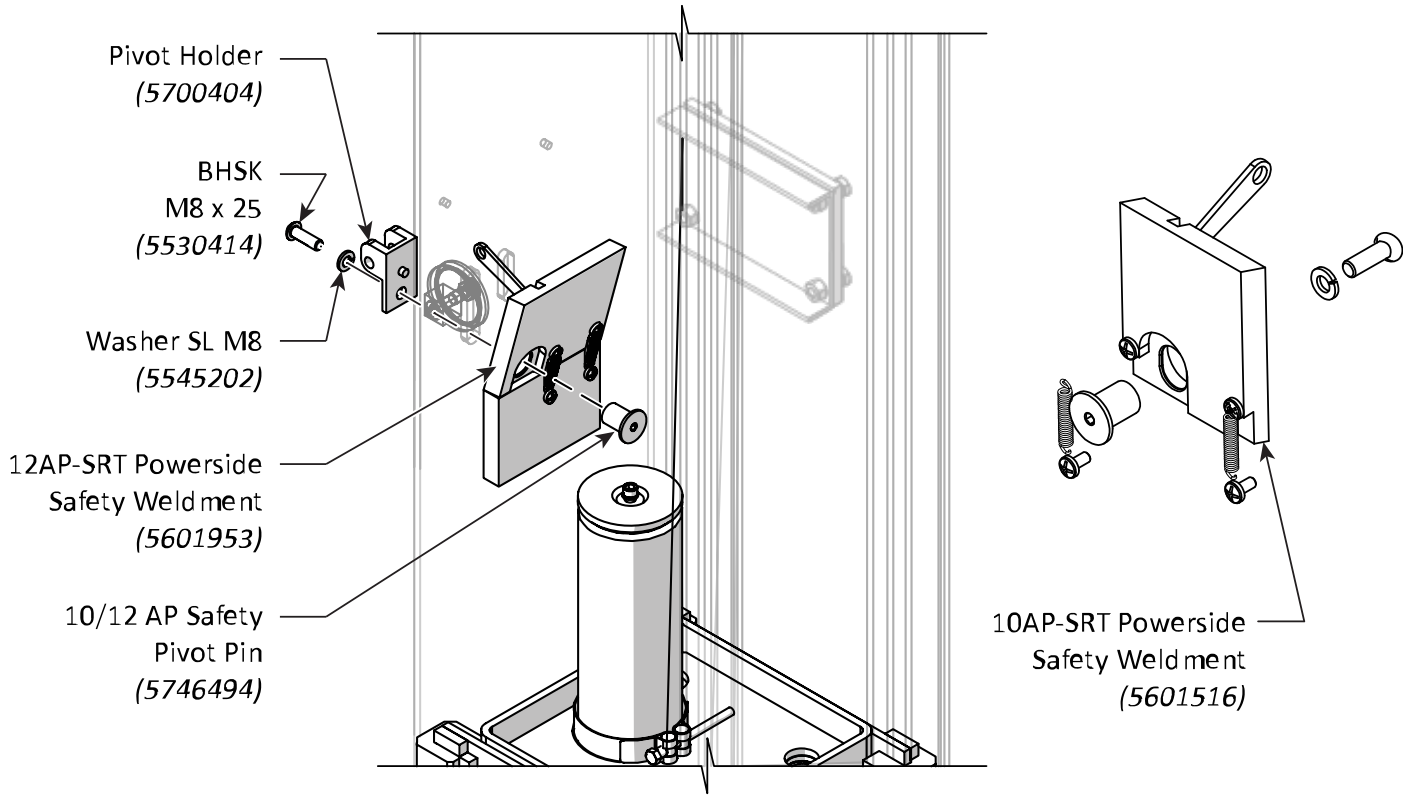

Routing and Connecting the Safety Lock Cable

The following procedure describes the safety lock cable routing and connection.

To route and connect the Safety Cable:

1. Locate the safety lock cable (5595793) for the Lift. The cable is $\text{Ø}1.8 \text{ mm} \times 7,773 \text{ mm}$ long with a ball crimp on one end. Refer to the figure below.

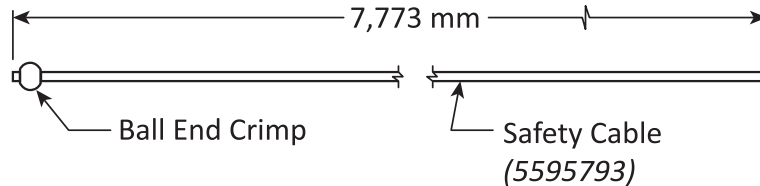

2. **Beginning on the inside of the Off Side Post**, push the **bare wire end** of the safety lock cable through the tab of the offside safety lock and wind the cable through the safety sheaves as shown in the figure below.

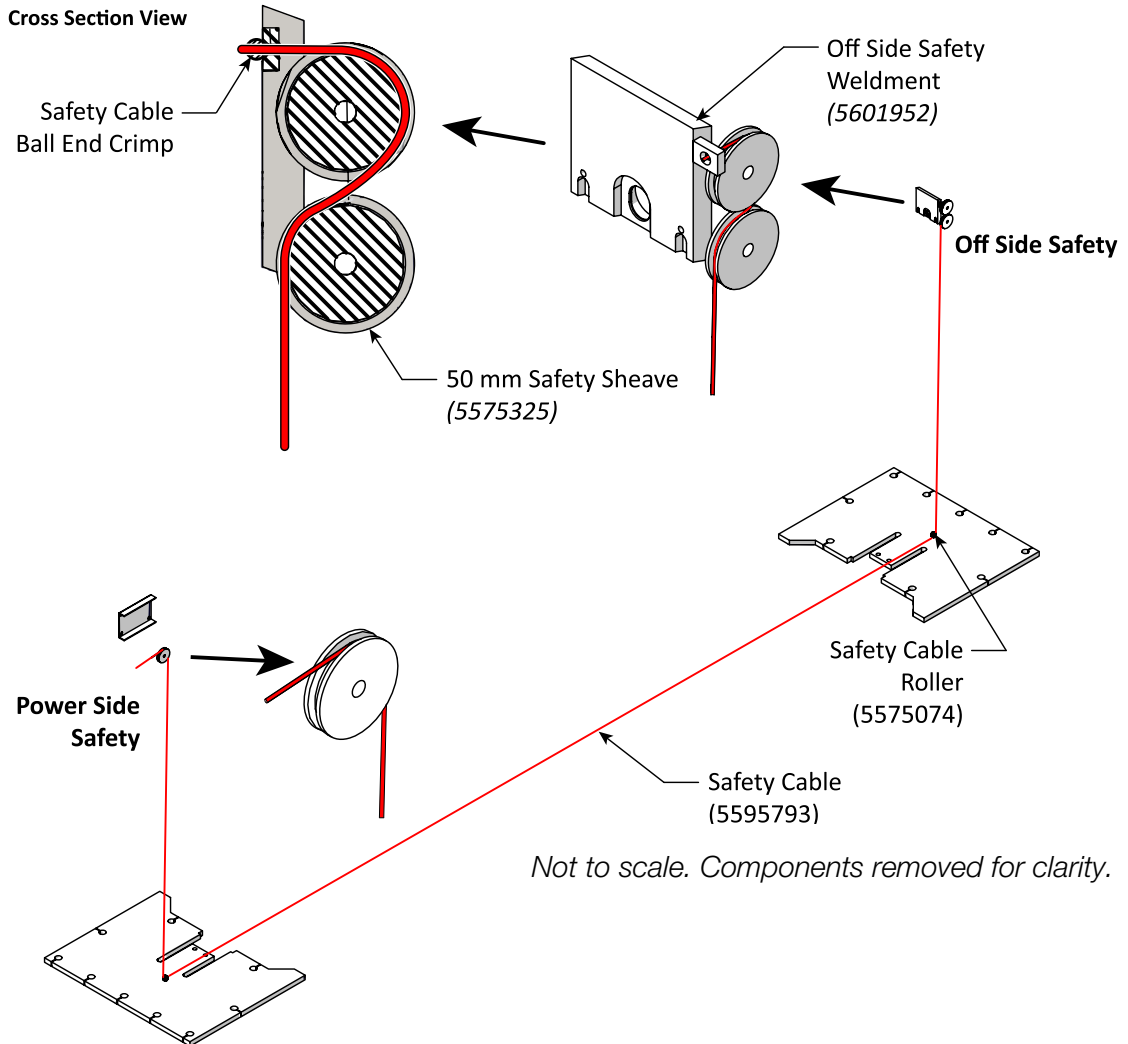

3. Route the bare wire end of the safety cable through the safety sheaves, as shown in the figure above and below.

Off Side Safety Roller

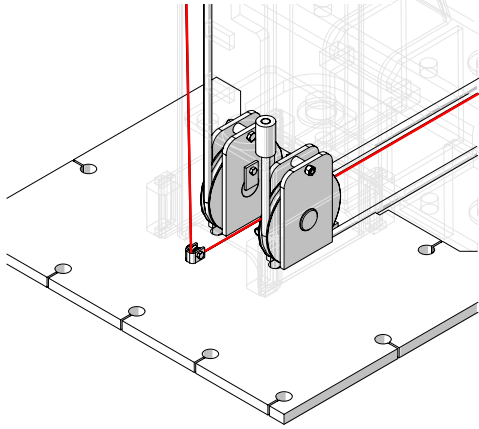

Power Side Safety Roller

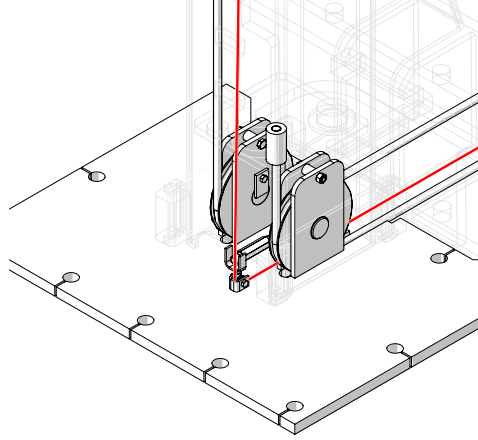

CAUTION

When connecting the ends of the safety lock cable, verify the cable remains securely seated in all the safety sheaves and rollers without interfering with the hydraulic hoses and equalizing cables.

4. Retrieve two M12 hex nuts and M12 x 25 mm flat washers from the parts bag.
5. Thread the hex nuts and washers onto the safety handle weldment leaving the cable opening accessible. Refer to the figure below.

6. Insert the safety cable through the opening in the safety handle weldment pull the slack out of the cable and lightly snug the hex nuts to hold the cable in place.

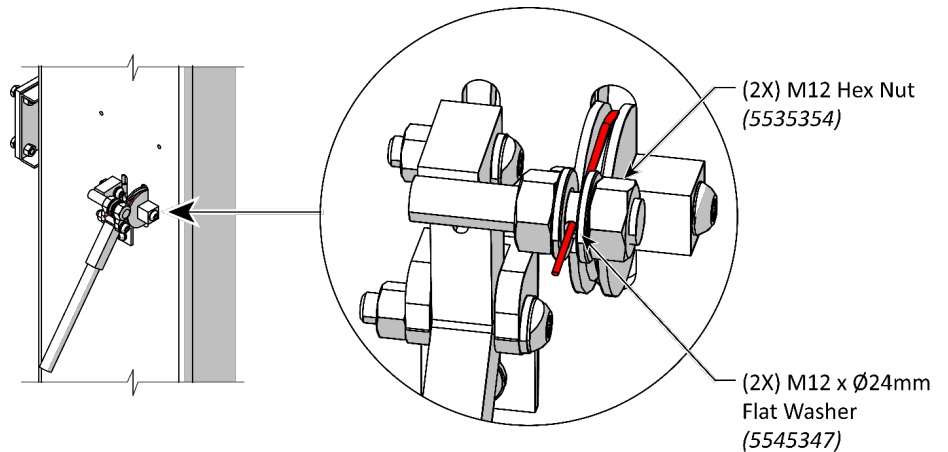

7. Operate the safety release handle. Adjust the safety cable tension until both safety locks move freely. The locks must pull clear of the lift head blocks when the safety release handle is pushed.

CAUTION

When tightening the hex nuts securing the safety cable to the safety release handle, keep tension on the safety cable and keep the cable centered between the two hex nuts.

8. Operate the safety lock release handle, checking for smooth and proper operation of both safety assemblies.

DANGER

Verify that both the power side and the off side safety assemblies engage properly **before** operating the Lift.



IMPORTANT! PLEASE READ NOW



Hydraulic Fluid Contamination poses a significant issue for your Lift; contaminants such as water, dirt, or other debris can be introduced into the hydraulic hoses and fittings on the Lift, making your new Lift inoperable and unusable.

Your Lift is shipped with clean components; however, BendPak strongly recommends that you take secondary precautions and clean all hydraulic hoses and fittings prior to making connections. It is better and less costly to take these extra steps now so that you do not need to take your Lift out of service later to fix issues that could have been prevented at the time of installation.

There are several ways to clean hydraulic hoses and fittings:











- **Compressed Air.** Use an air compressor to blow out contaminants from each hydraulic hose and fitting prior to installation. Clean, dry air is preferred. Wear ANSI-approved eye protection (safety glasses, goggles, or face shield) when using compressed air for cleaning. Never point an air hose nozzle at any part of your body or any other person.
- **Fluid Flushing.** If the hydraulic fluid is clean and compatible with the system fluid, you can flush hoses and fittings to create turbulent flow and remove particulates. Always ensure that the fluid itself is contaminant-free.

Some additional steps that will help keep the hydraulic fluid clean:

- **Remove old thread seal tape.** Some ports on the hydraulic cylinders are shipped with temporary plugs secured with thread seal tape. Make sure to thoroughly remove any remaining thread seal tape that may inadvertently enter the hydraulic system.
- **Use a liquid thread sealant only.** Liquid thread sealant (Loctite™ 5452 or similar) is recommended. Do not use thread seal tape on any fitting. Liquid thread sealant is recommended for all NPT connections, fine for JIC connections, but *not* necessary for O-ring (ORB) connections.
- **Always use clean equipment.** If you use a dirty bucket or funnel to transfer the hydraulic fluid into the hydraulic fluid reservoir, contaminants will be introduced into the fluid. When using cleaning rags, use a lint-free rag.
- **Proper storage.** Keep the hydraulic fluid sealed in its container until ready for use; store the fluid in a clean, dry, and cool area.
- **Cover the Hoses and Fittings.** Before installation, do not leave the ends of the fittings open and exposed; the same applies for the hydraulic hoses. Generally, keep the hydraulic hoses and fittings capped and in a clean area until ready for use.
- **Filter the new Hydraulic Fluid.** Just because it is new does not mean it is *clean*. Use an offline filtration cart or kidney loop system to verify the hydraulic fluid is clean before being transferred into the hydraulic fluid reservoir (even using a heavy-duty nylon mesh screen is better than trusting what is left at the bottom of the barrel).
- **Avoid mixing different types of Hydraulic Fluid.** If hydraulic fluid must be replaced, make sure to flush the hydraulic system of the old hydraulic fluid before you add the replacement fluid; do not mix the two together.

Hydraulic System Warnings

Before applying power to the Hydraulic System note the following Warnings:

-  **WARNING** Failure to observe these warnings can result in serious personal injury including, in rare cases, death.
-  **WARNING** The hydraulic hoses and connections **must** be inspected before any attempt to raise a vehicle is made.
-  **WARNING** **Verify** all hydraulic hose connections and fittings, including unused auxiliary port plugs on the power unit, the flow divider (if present), the cylinders and anywhere else in the hydraulic system are tightened.
-  **WARNING** The power unit is a Hydraulic Pump capable of developing pressures in excess of 5,000 psi (345 BAR). A pressure relief valve is used to set the pressure at the desired level. Tampering with, adjusting, modifying, or removing the relief valve is extremely dangerous and is not permitted. Only trained hydraulic technicians are permitted to adjust the pressure relief valve, using calibrated hydraulic pressure gauges to ensure the proper pressure setting is achieved.
-  **WARNING** Changes to the output pressure may render the power unit incompatible with pressure limitations of other components in the hydraulic circuit. This may cause catastrophic failure of those components, and could result in property damage, serious personal injury, or death.
-  **WARNING** The hydraulic system can contain high pressure which, if suddenly released, can cause severe injury or death.
-  **WARNING** Do **not** attempt to connect or disconnect hydraulic hoses while the equipment is loaded or while a vehicle is on the Lift, or the hydraulic system is under pressure.
-  **WARNING** Keep bare hands away from hydraulic fluid; always wear gloves when handling hydraulic fluid, cylinders, or hydraulic hoses.
-  **WARNING** When handling hydraulic fluid, always observe the safety instructions from the manufacturer.
-  **WARNING** **Always** promptly clean any hydraulic fluid spills. If a leak is the source of the spill, lock out the Lift to prevent use until the hydraulic system is repaired.

About Thread Sealants

Liquid thread sealant lubricates and fills the gaps between the fitting threads and leaves no residue that could contaminate the hydraulic fluid. Other types of thread sealants (like Teflon Tape) can shred during installation or removal and eventually enter the Hydraulic System. Thread sealant may be used with most hydraulic fittings, although you only need to use it with NPT connectors.

To apply Thread Sealant:

1. Apply the thread sealant when the ambient temperature is between +46.5°F to +70°F (+8°C to 21°C) Make sure the fittings and connectors are clean and dry.

- If you are adding thread sealant to a fitting or connector that has already been used with a different sealant, use a wire brush to thoroughly remove the old sealant before adding more.
- Skipping the top thread, apply a small amount of thread sealant to the next four threads of the NPT fitting.

⚠ WARNING Always wear the proper protective equipment when handling thread sealant.

Only a small amount is required. The sealant will spread to the other threads as it is tightened into place.

If too much sealant is used, the excess liquid will be pushed out when the fitting is tightened; use a rag to clean the excess sealant.

- Tighten the fitting into the connector; do **not** over tighten the fitting.
- Allow the manufacturer-recommended curing time before pressurizing the system.



Routing and Installing the Hydraulic Hoses

Hydraulic hoses transmit fluid power from the power unit to the lift cylinders. The figure below displays an overview of the hydraulic hose installation.

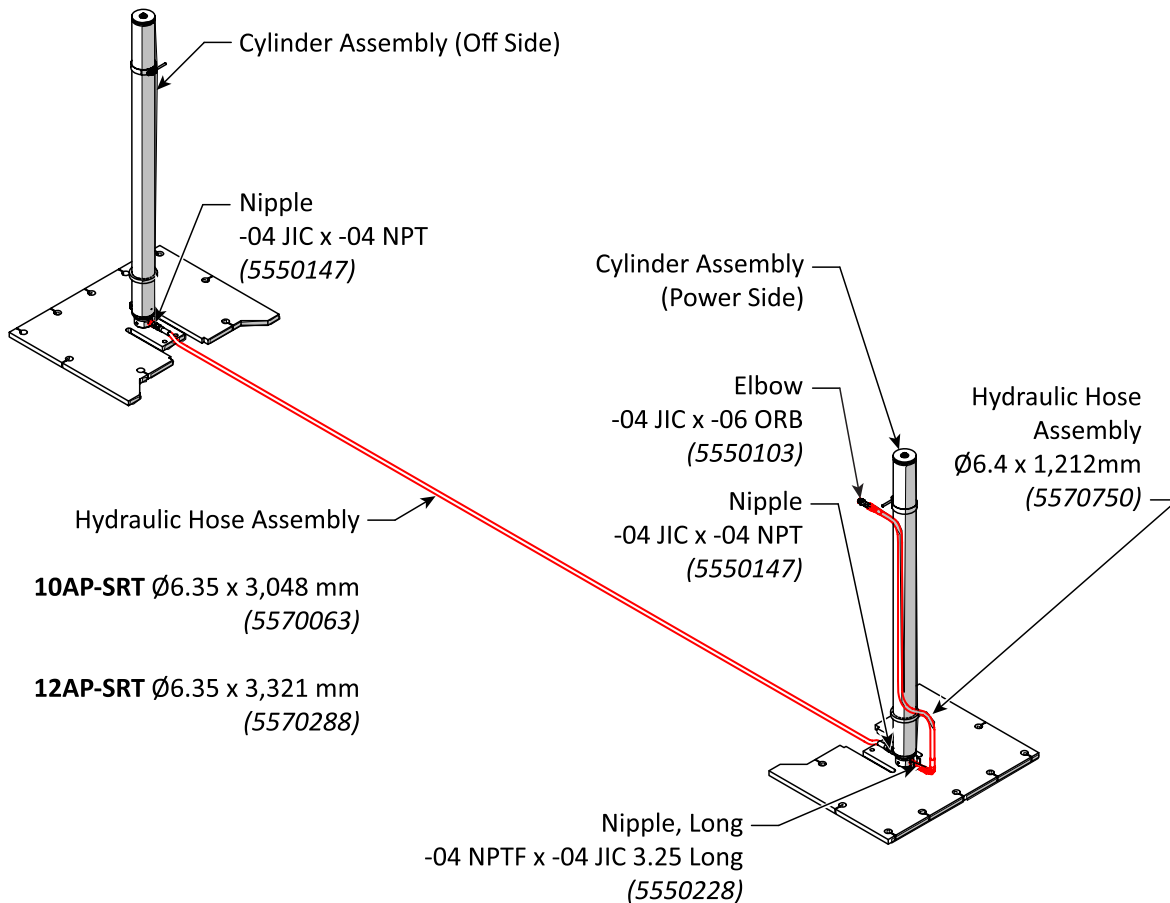

Pictured above is the hydraulic hose routing for both the 12AP-SRT and the 10AP-SRT.
Components removed for clarity.

⚠ CAUTION Do not overtighten JIC fittings! Damage to the hose or fitting is likely.

1. Retrieve the hydraulic hoses for the model and configuration as detailed in the table below.

Model	Part Numbers	Description
10AP-SRT	5570063	Hyd. Hose Assy. Ø6.35 x 3,048 mm
	5570750	Hyd. Hose Assy. Ø6.40 x 1,212 mm
12AP-SRT	5570288	Hyd. Hose Assy. Ø6.35 x 3,321 mm
	5570750	Hyd. Hose Assy. Ø6.40 x 1,212 mm

2. The nipples at the bottom of the lift cylinders were put in place while installing the equalizing cables. Return to that section if the nipples have not been installed.
3. Connect the long hydraulic hose to the nipple at the bottom of the offside cylinder. Refer to the figure below.

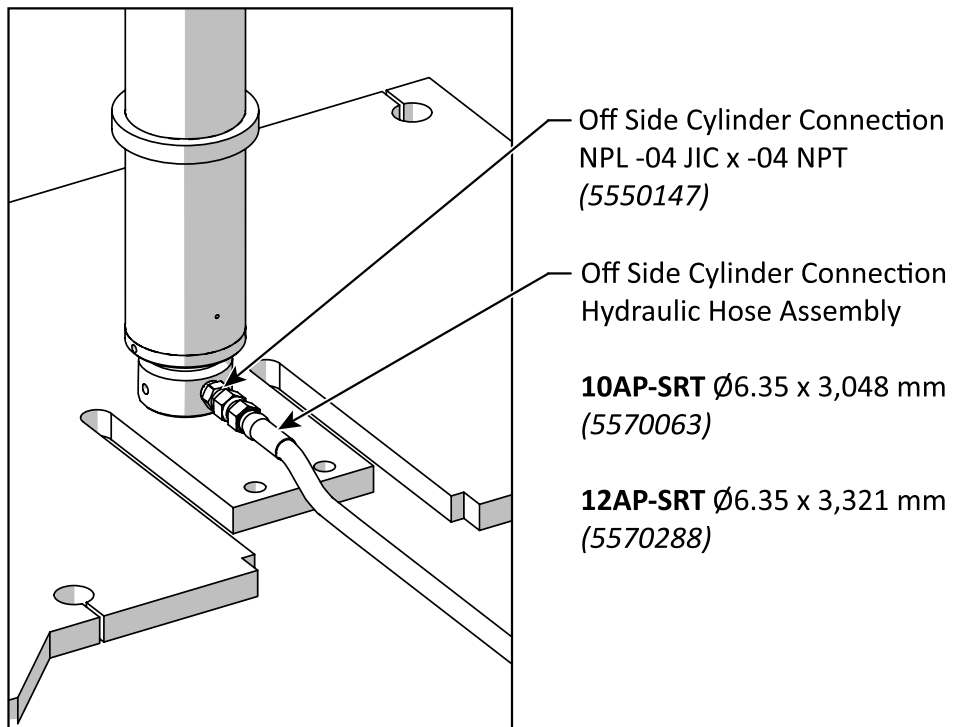

Components removed for clarity.

6. Connect the open end of the long hydraulic hose to the nipple at the bottom of the power side cylinder. Refer to the figure below.

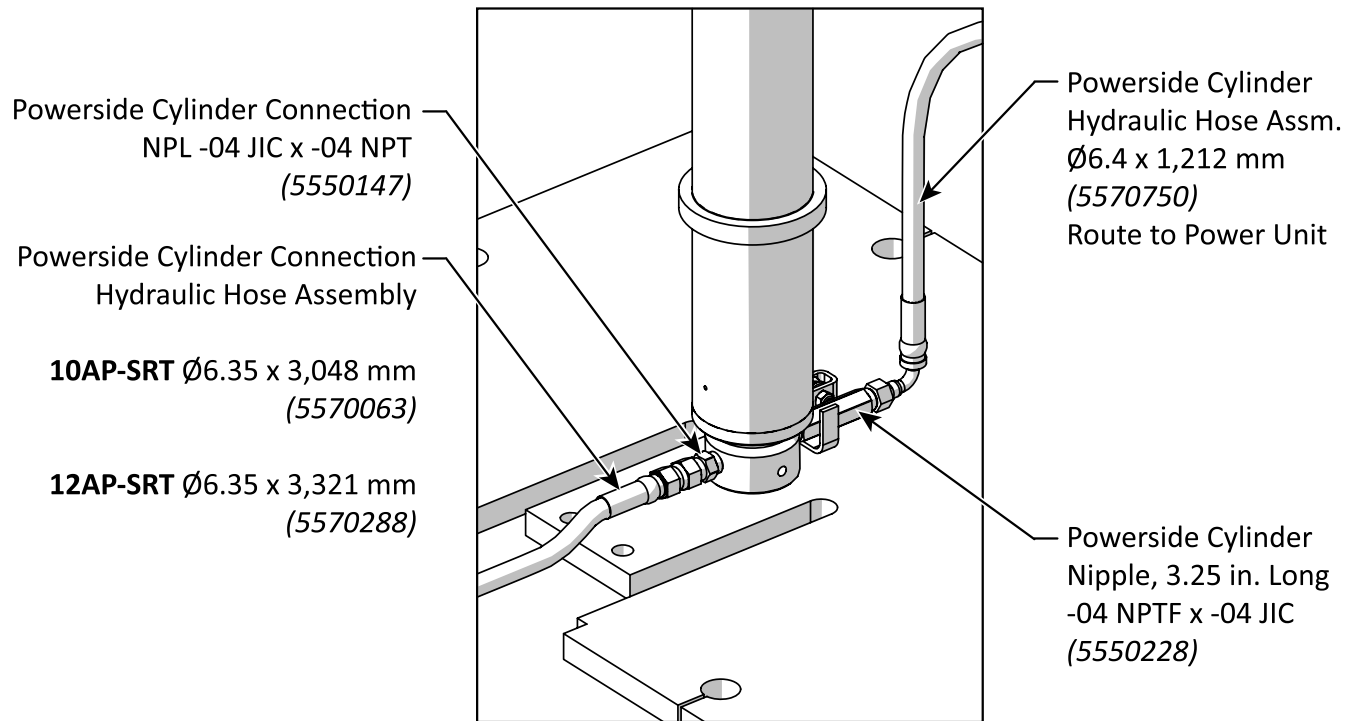

Components removed for clarity.

7. **All models** connect the hydraulic hose (5570750) to the long nipple on the power side cylinder. This hose will be connected to the power unit in the next section.

Mount the Power Unit

This section describes how to mount the Power Unit to the Power Post. You do **not** need an Electrician to **mount** the power unit, but you do need an Electrician to **connect** the power unit.

Important: Do not connect the power unit to the Hydraulic System or to the power source at this point in the installation; those connection will be made later.

CAUTION The power unit is heavy. BendPak recommends having one person hold the power unit while a second person bolts it into place. Alternatively, a forklift or small scissor lift may be used to bring power unit into position on the Lift Post.

The power unit **must** be mounted on the mounting bracket on the Power Side Post.

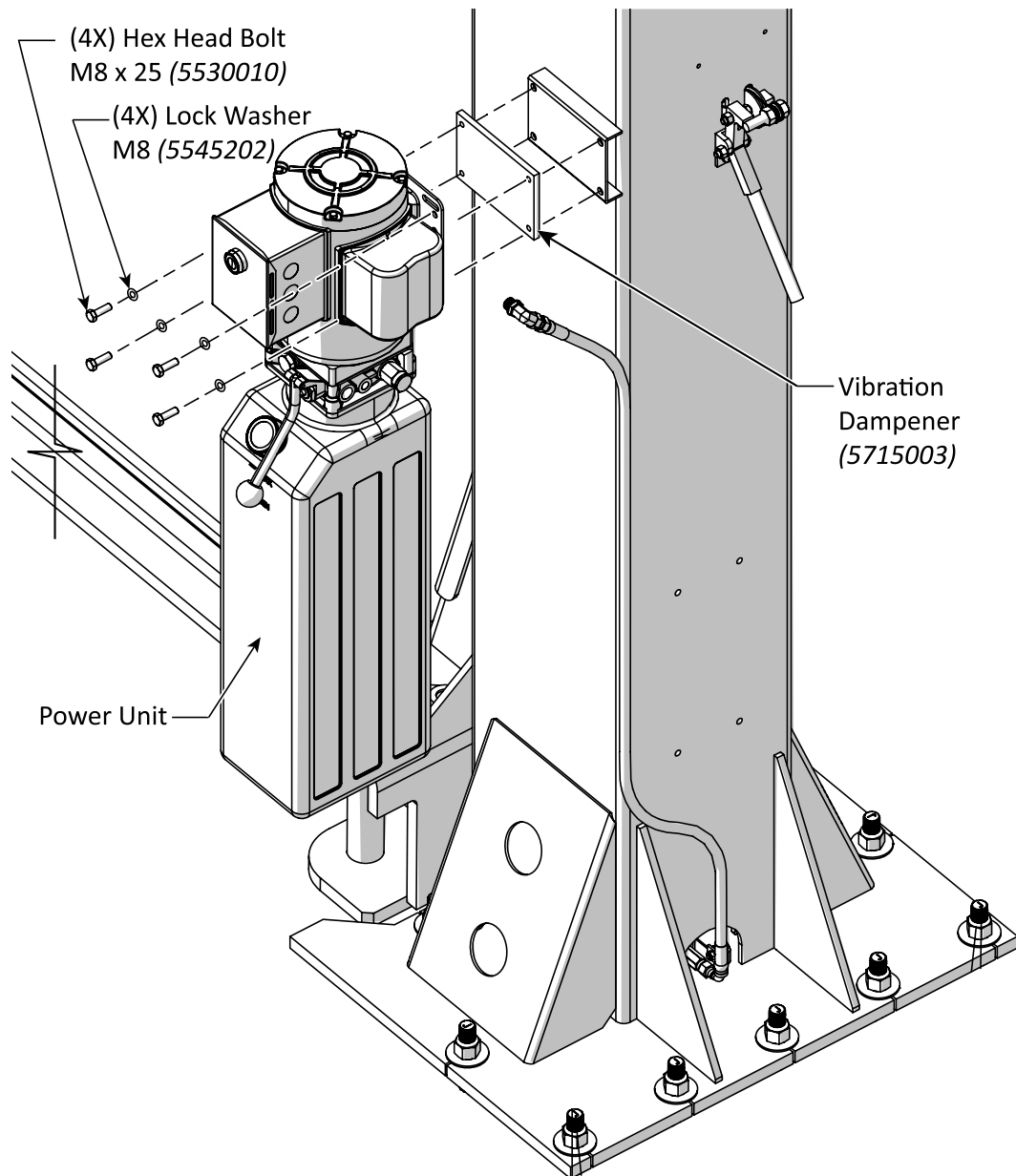

To mount the Power Unit to the Power Side Post:

1. Retrieve the supplied M8 Hex Head Bolts, and Lock Washers from the Parts Bag. Retrieve the Vibration Dampener from the Parts Box.
2. Carefully remove the Power Unit from the shipping material.
3. Position the vibration dampener in place next to the mounting bracket on the Power Side Post.
4. Position the mounting plate on the back of the power unit next to the vibration dampener.
5. Push one of the bolts through a hole in the motor mounting plate, through the vibration dampener, and thread into the mounting bracket and make finger tight.
6. Repeat Steps 4 and 5 for the other three bolts and lock washers, then tighten using appropriate tools.

Connect the Hydraulic Hose to the Power Unit

The following procedure assumes the Hydraulic Lines were placed in position earlier in the installation. Refer to **Routing Hydraulic Hoses** for more information. If they were **not** put into position earlier, do so now, **before** beginning the following procedure.

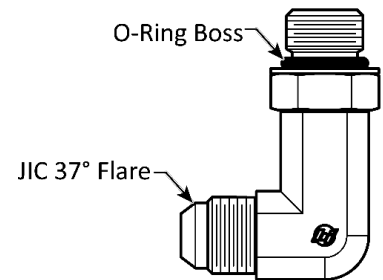

To connect the final Hydraulic Line:

1. Locate the short hydraulic hose and the remaining elbow hydraulic fitting with O-ring.
2. **On the power unit**, locate a hydraulic pressure out port on the power unit (labeled **P1**, or **P2**), remove the shipping plug. *Place a few drops of hydraulic fluid on the O-Ring* of the elbow hydraulic fitting (-04 JIC to -06 ORB) and install in the P1 or P2 port of the power unit.
3. The figure below details locations of the hydraulic pressure ports on the 5585685 power unit that is available for the 12AP-SRT Lift.
4. Connect the hydraulic hose to the JIC end of the elbow just installed and make finger tight.
5. Using appropriate tools, go back and securely tighten all hydraulic fittings.

⚠ CAUTION Do not overtighten JIC fittings! Overtightening is a common cause of leaking or damaged fittings and hoses. Tighten by hand until the faces seat. Then use a wrench to tighten 1 to 1.5 turns for the -06 and -04 fittings used here.

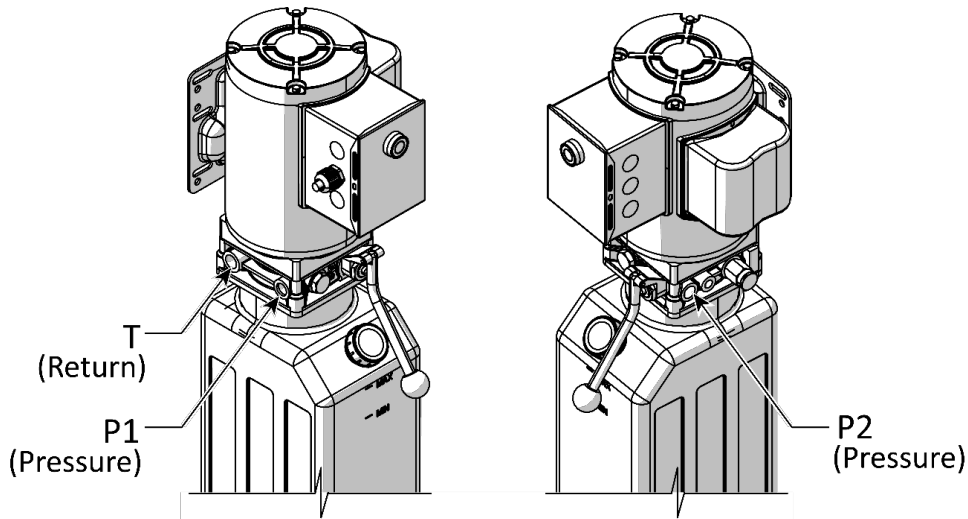

Install the Cylinder Clamps

⚠ WARNING Verify the cylinder clamps are positioned at the top of the lift head and secured, one clamp on **each** cylinder! **Do not operate the Lift if the cylinder clamps are not secured on the hydraulic cylinders.**

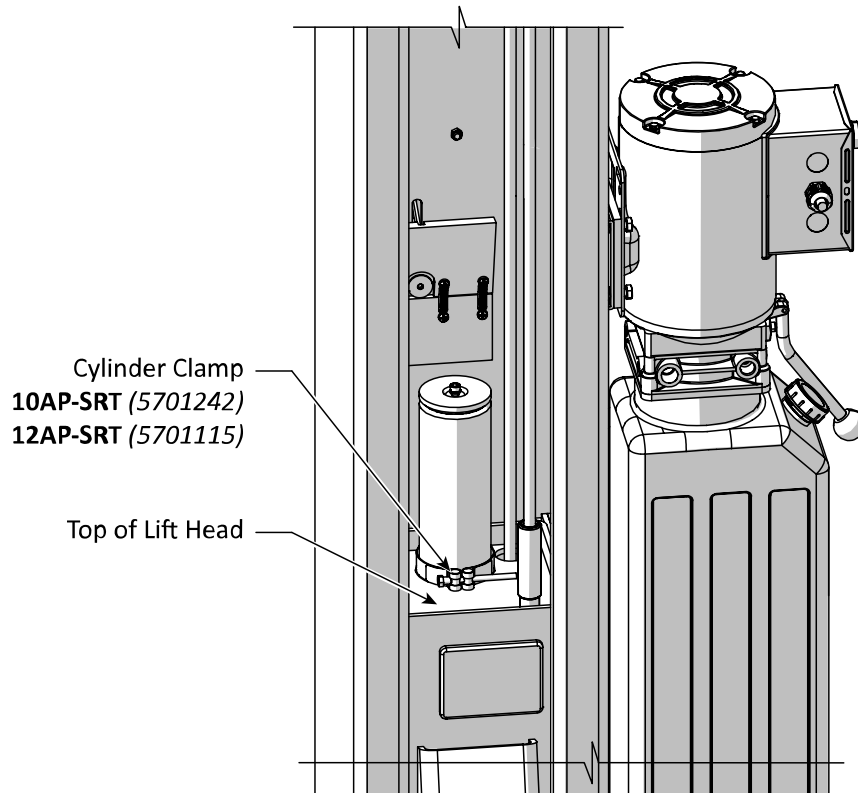

Install the Lift Arms

Lift Arms are connected to the lift head and contact the vehicles at specific lift points. The Lift is supplied with four lift arms, two Asymmetric Arms and Two Long Arms as detailed in the figure below.

The lift arms may be installed on either side of the Lift, but the same type of arm must be on the same side as detailed in the figure below.

The **next task** is to determine the Front and Rear of the Lift:

- **If a vehicle can only drive into the Lift one way**, then the approach side is the Rear, the other side is the Front.
- **If a vehicle can drive in either way**, then choose one side as the Front and the other side as the Rear. The best way to make this decision is to pick one approach direction for the vehicles you will be servicing on the Lift, even though you can drive in either way. Also consider the ease of backing out of your chosen approach. Once the decision is made, if a vehicle approaches the Lift from the Rear, the opposite side is the Front.

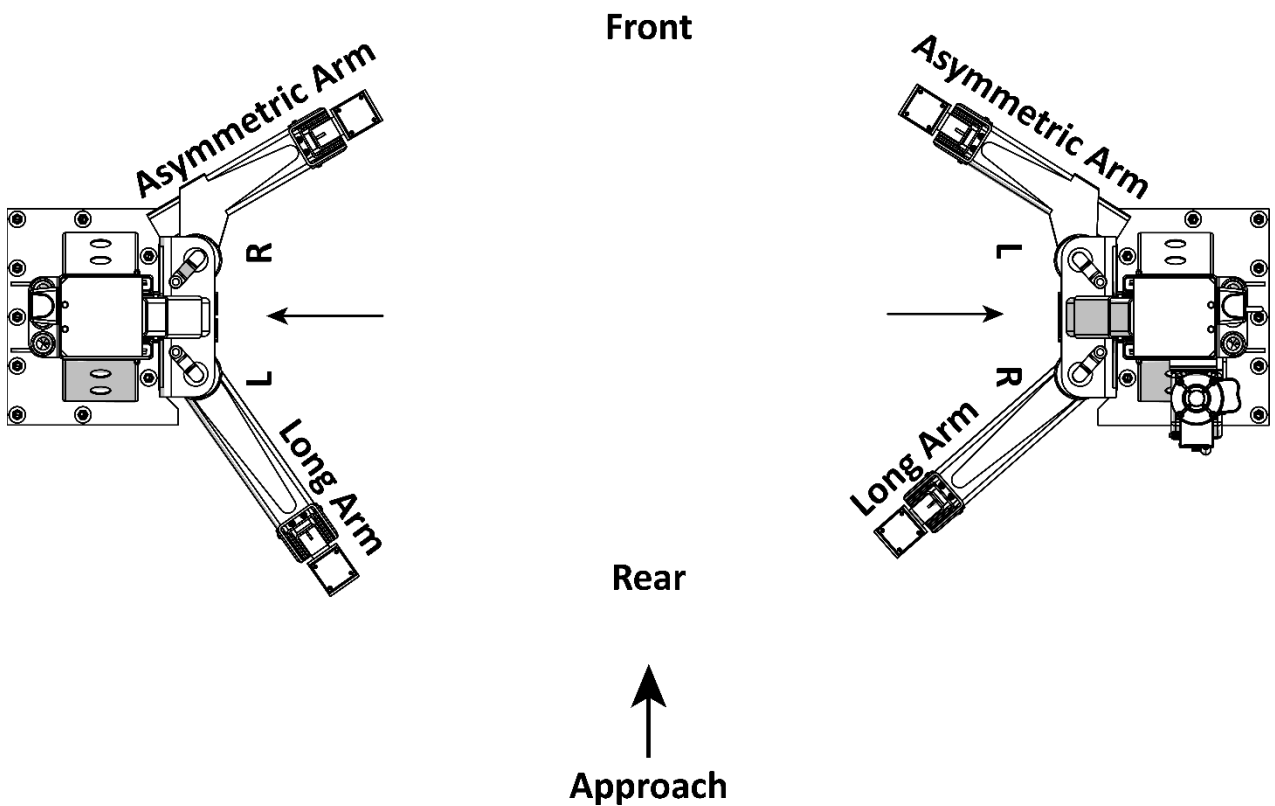

To install a Lift Arm in a Lift Head:

1. Use a Forklift or Shop Crane to raise the lift heads to the first locking position.

⚠ DANGER The Lift Head and Arms are heavy. Block the downward motion of the Lifts Heads with a jack stand or 4 x 4 lumber while installing the Lift Arms. Exercise caution when lifting the Arms and raising the Lift Head to the first locking position. Use appropriate equipment to raise the Lift Heads.

2. Loosen the M6 Set Screw to remove the Arm Lock Guide Rod, Release Handle, Compression Spring and Arm Internal Gear Stop.

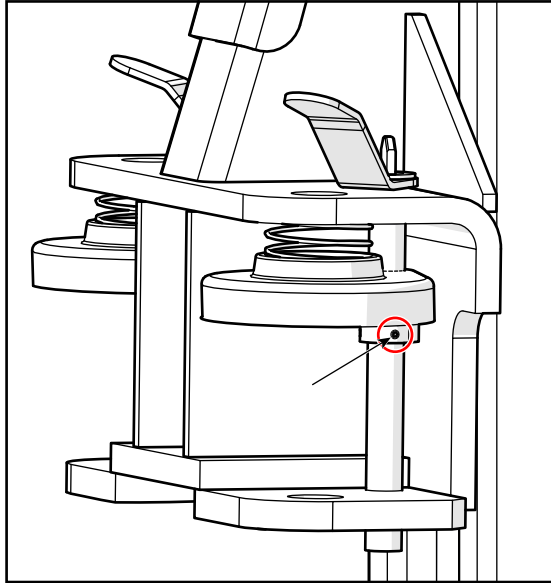

3. Place a Gear Stop and Spring on the Lift Arm Assembly.

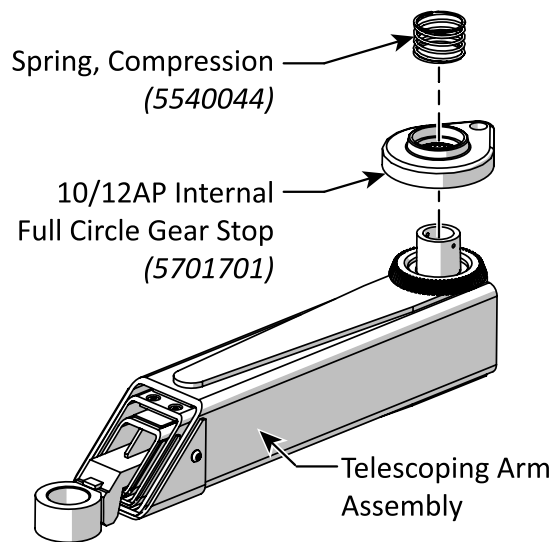

Reference only – do not scale.

4. Move the appropriate Lift Arm into place in the lift head, then Slide the Arm Lock Guide Rod and Handle through the holes in the lift head and Lift Arm Assembly.

The holes at the end of the Gear Stop must be aligned with the holes in the lift head.

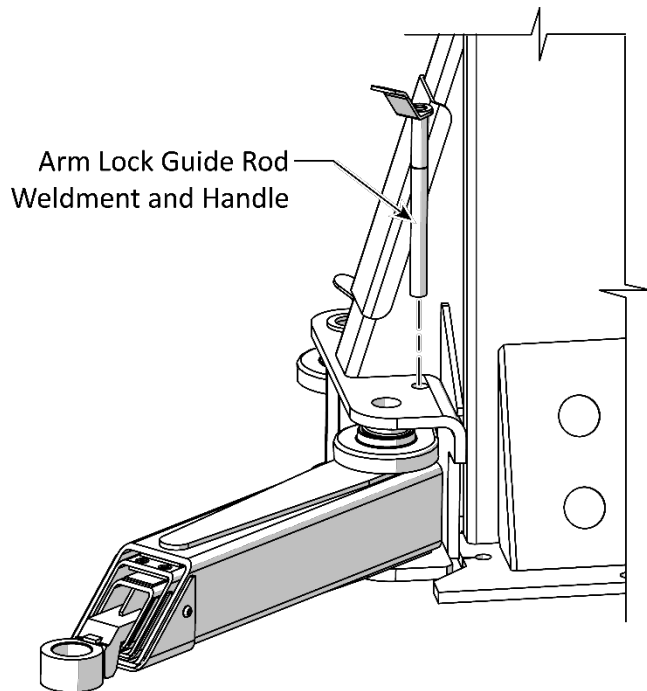

5. Secure the Arm Lock Guide Rod with the M6 Set Screw tightened into the groove machined into the Arm Lock Guide Rod.

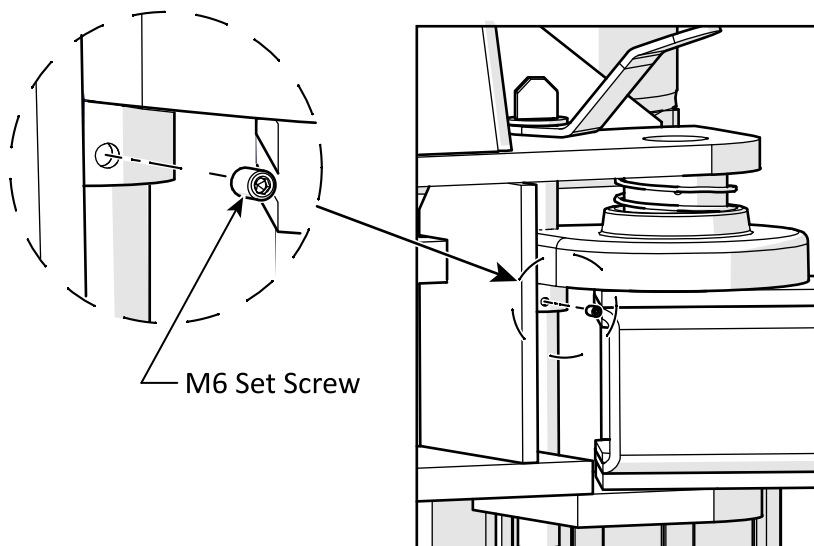

- Slide the Arm Lock Pin through the openings in the lift head and the Lift Arm Assembly.

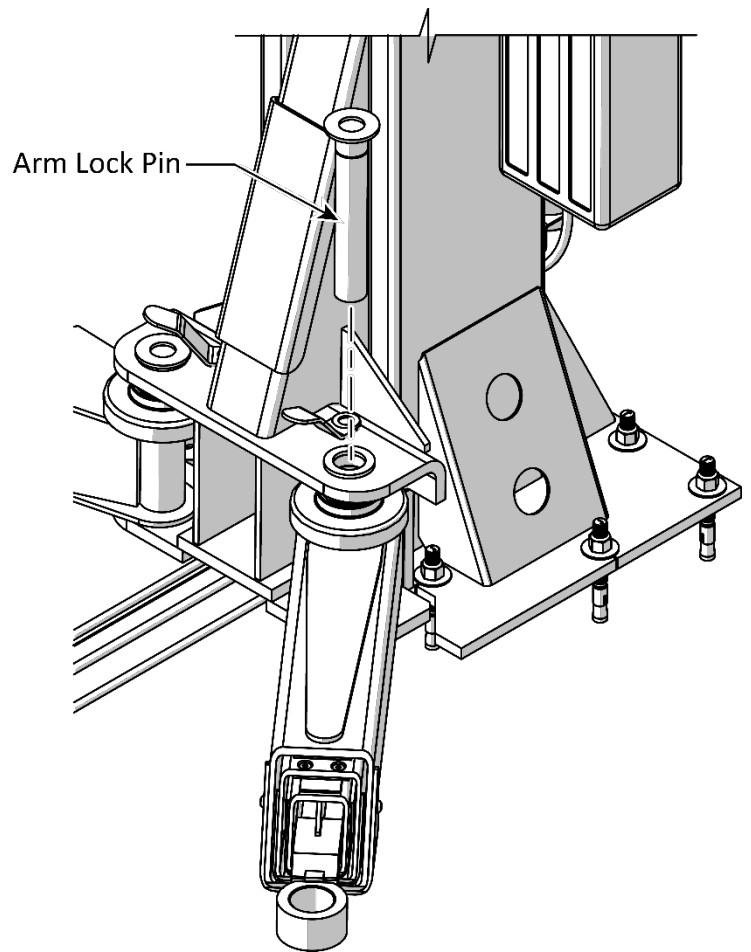

- Secure an M6 Set Screw as shown in the figure below; one Set Screw on each Lift Head Pin.

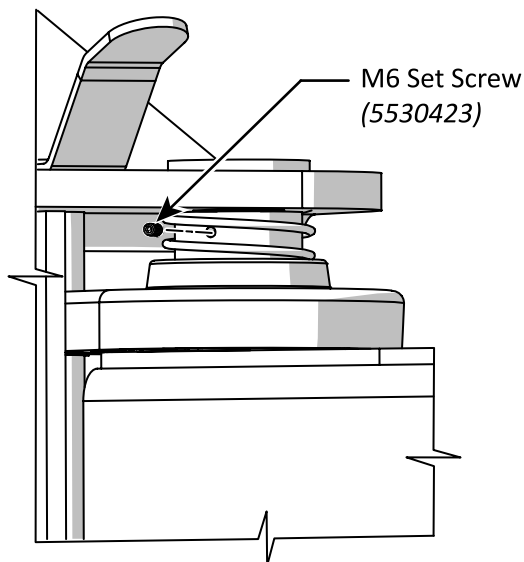

8. Repeat Steps 1 – 7 for the other three lift arm assemblies.
9. Apply lateral force to the Lift Arms while the restraint gears are engaged.

⚠ WARNING Verify that the arm restraint gears, and the gear stops are meshing and stay in place when up to 150 pounds of lateral force is applied prior to putting the Lift into normal operation.

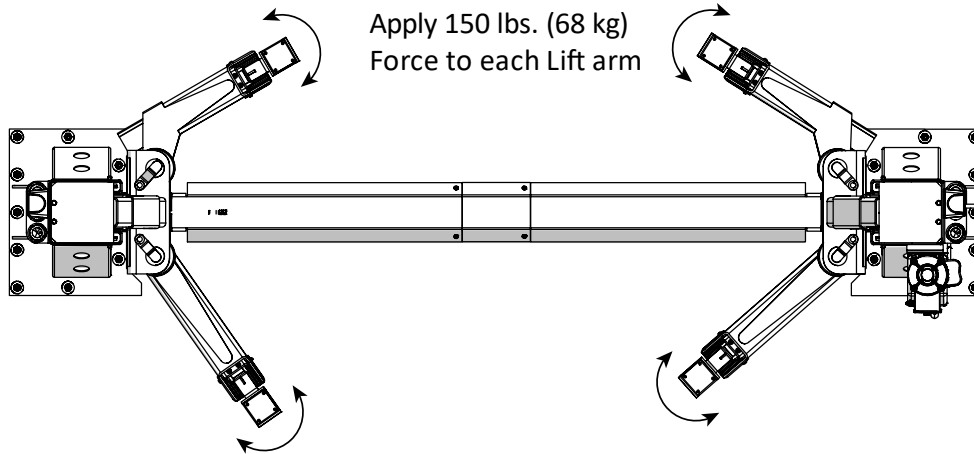

⚠ DANGER Each lift arm assembly **must** be inspected and adjusted as required before each use. Do not operate the Lift if any of the four lift arm restraint systems are not functioning correctly. Replace any damaged components only with approved replacements.

10. While the lift heads are elevated, install the height adapter holders on each post using two M6 x 20 BHSK, two M6 x Ø12 mm flat washers, and two M6 nylock hex nuts on each holder. Refer to the figure on the right.

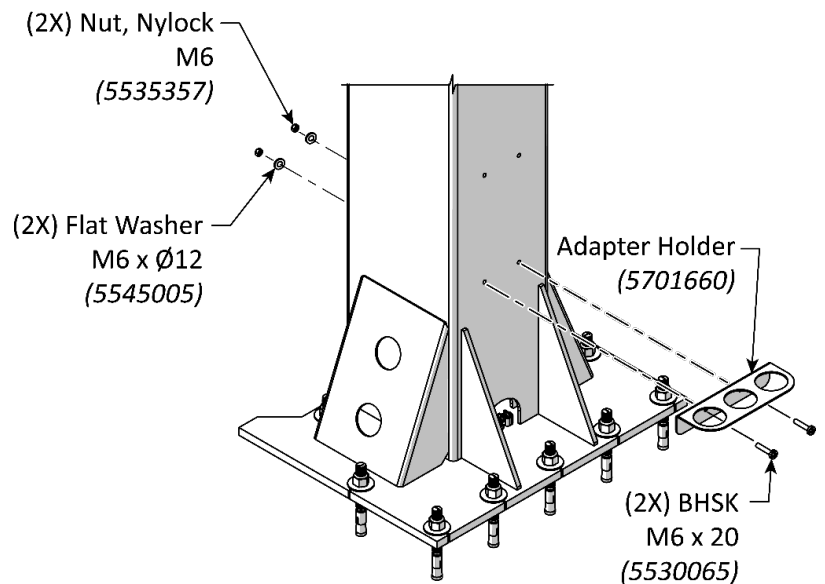

Contact the Electrician

Following are installation tasks that require a licensed Electrician.

⚠ DANGER A licensed Electrician must perform all wiring in accordance with national, state, and local electrical codes.

The Electrician is required to:

- **Connect to facility power.** The Electrician is responsible for routing, protecting, and connecting electrical power to the Lift. The power unit is delivered with a pigtail for wiring to a power source. Have your Electrician connect a power cord with plug to the electrical junction box on the power unit (for connection to a power outlet) or have them wire it directly into the facility electrical system at the Lift location protected by an appropriate circuit breaker.
- **Install a Power Disconnect Switch.** Ensures the operator can quickly and completely interrupt electrical power to the Lift in the event of an electrical circuit fault, emergency, or when equipment is undergoing service or maintenance. The Electrician must install it within sight and easy reach of the Lift operator. Refer to **Installing a Power Disconnect Switch** for more information.
- **Install a Thermal Disconnect *if required by local electrical codes.***

The Electrician is responsible for providing:

- A power cord and appropriate 220 VAC plug for connecting to a power source or the items required to safely connect to the facility's power system.
- a Power Disconnect Switch
- a Thermal Disconnect, *if required by local electrical codes.*

Additional information is supplied in the sections describing these tasks.

Electrical Information

⚠ DANGER All wiring and connections to electrical power **must** be performed by a licensed Electrician in accordance with local and national electrical codes. Do not perform any maintenance until main electrical power has been disconnected from the Lift and cannot be re-energized until all procedures are complete.

Important electrical information:

- The **Wiring Diagram** included in this manual may not correspond to the power unit delivered with the Lift. Always use the wiring diagram on the inside of the power unit junction box cover.
- Improper electrical installation can damage the power unit motor, which is not covered by the warranty.
- This Lift uses electrical energy; if your organization has Lockout/Tagout policies, make sure to implement them after connecting to a power source.
- Use a separate circuit breaker for each power unit.
- Protect each circuit with a time delay fuse or appropriate circuit breaker for the power unit in use:

Connect the Power Unit

The power unit must be connected to an appropriate electrical power source.

⚠ DANGER A licensed Electrician **must** perform all wiring in accordance with national, state, and local electrical codes. Do not perform any maintenance or installation on the Lift without first verifying that main electrical power has been disconnected from the Lift and cannot be re-energized until all procedures are complete. The Lift uses electrical energy; if your organization has Lockout/Tagout policies, make sure to implement them after connecting to a power source.

To prepare your power unit for operation:

- Mount the power unit to the Power Side Post. Described in **Mount the Power Unit**.
- Attach the Hydraulic Line to the correct location on the power unit. Described in **Routing and installing the Hydraulic Lines**.
- Attach the power unit and Microswitch to a power source. Reference the **Wiring Diagram** (Electrician required).
- Fill the hydraulic fluid reservoir.

The Power Unit

The **12AP-SRT** Lift is currently available with a 220 VAC, 50/60 Hz, 1 Phase, 5 HP Power Unit (5585685).

The **10AP-SRT** has two power units currently available.

1. 208 – 240VAC, 1 Phase 50/60 Hz. 3 HP (5585285)
2. 208 - 230VAC, 1 PH, 50/60 Hz. 2 HP (5585785)

Specialized 3 Phase, Low RPM power units are also available on request.

Several different vendors provide power units to BendPak. There may be minor differences in look and feel. Nevertheless, all power units of the same type provide the same level of functionality.

All power units are shipped with a 'pigtail' exiting the Electrical Box. To connect the power unit, remove the pigtail and make connections in the Electrical Box.

The figure to the right is a front view of a typical power unit. Your specific power unit may look different based on the type purchased/supplied.

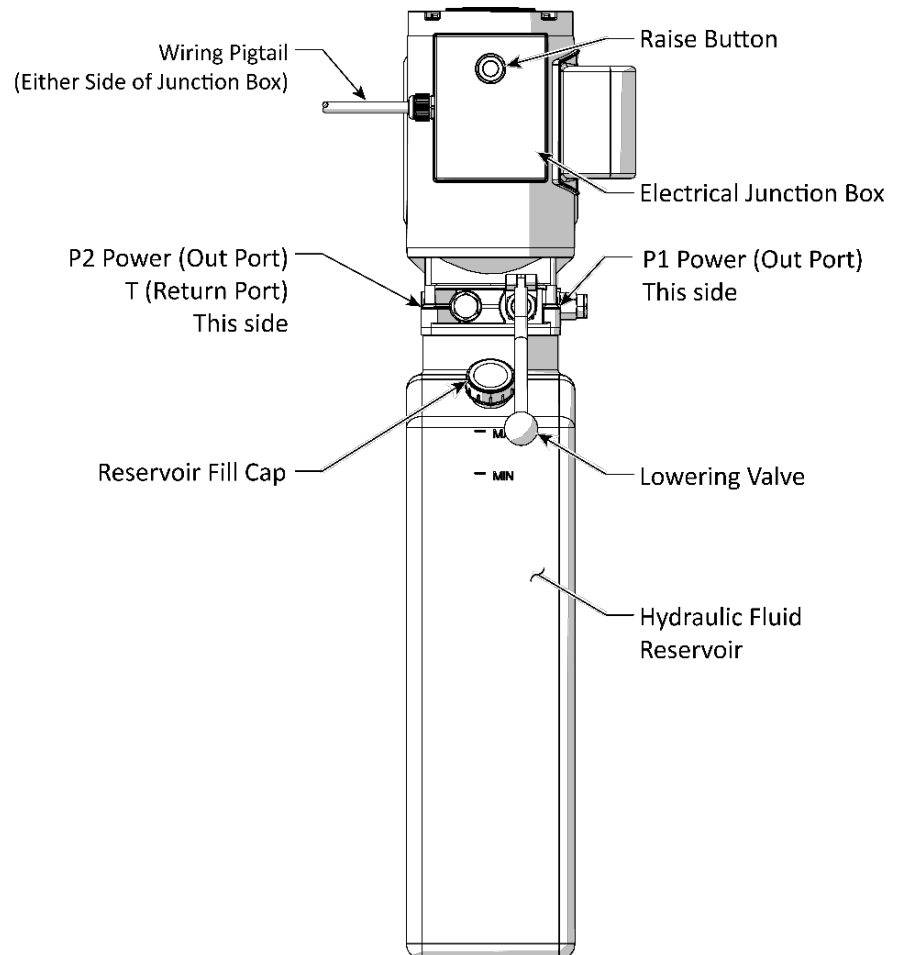

Note: The Raise Button shown in the figure could be in a different location on the unit or could be a rotary switch instead of a button, depending on the power unit delivered.

Instruct the Electrician that all electrical work **must** conform to applicable local, state, and federal codes, rules, and regulations.

To prepare the Power Unit:

1. Have the Electrician locate the pigtail exiting the electrical junction box on the power unit.
2. Open the junction box, remove the pigtail, and then either:
 - Wire the power unit directly into the facility’s electrical system.
 - Wire a power cord (with appropriate plug) *inside the Electrical Box* to the wiring that was connected to the pigtail.

Wiring information is either on the outside of the power unit under the junction box or inside the cover of the junction box. Have the Electrician use that wiring information to wire the power unit to the power source.

3. Fill the hydraulic fluid reservoir with approved hydraulic fluid.

The reservoir holds ≈3.5 gallons of hydraulic fluid, depending on which power unit you have.

When you receive the power unit, the reservoir is empty.

Approved hydraulic fluids are any general-purpose ISO-32, ISO-46, or ISO-68 hydraulic oil or approved automatic transmission fluids such as Dexron III, Dexron VI, Mercon V, Mercon LV, Shell Tellus S4 / S3 / S2, or any synthetic multi-vehicle automatic transmission fluid.

 **WARNING** Do not run the power unit without hydraulic fluid; you will damage it.

Important electrical information:

- Improper electrical installation can damage the power unit motor; this damage is **not** covered by the warranty.
- Use a separate circuit breaker for each power unit.
- Protect each circuit with a time-delay fuse or circuit breaker appropriate for the power unit in use.
 - 220 VAC, single phase circuit.
- The Electrician is also required to supply and install the Power Disconnect Switch and, if the local electrical code requires it, a Thermal Overload Disconnect.

 **DANGER** **Risk of explosion.** This equipment has internal arcing components and should **not** be exposed to flammable vapors. The power unit’s Motor should not be located in a recessed area or below floor level. The Motor should always be mounted above 18 in. (457 mm).

 **WARNING** Never expose the motor to rain or other damp environments; damage to the motor caused by water is not covered by the warranty.

Installing a Power Disconnect Switch

⚠ WARNING A Power Disconnect Switch is not provided with this equipment.

The Power Disconnect Switch is a National Electrical Code (NEC) requirement. They are designed to interrupt main electrical power in the event of an electrical circuit fault, emergency, or when equipment is undergoing service or maintenance.

Make sure to install a Power Disconnect Switch that is properly rated for the incoming power source.

The power disconnect switch must be readily accessible and installed so that it is within easy reach of the operator and in their line of sight. The power disconnect switch must be clearly marked to indicate its purpose.

The figure to the right displays a power disconnect switch located above power unit. A quick flip of the switch immediately cuts power to the Lift.

⚠ DANGER Installing a Power Disconnect **must** be accomplished by a licensed, Electrician.

The Electrician is to supply a **UL-listed** Power Disconnect Switch.

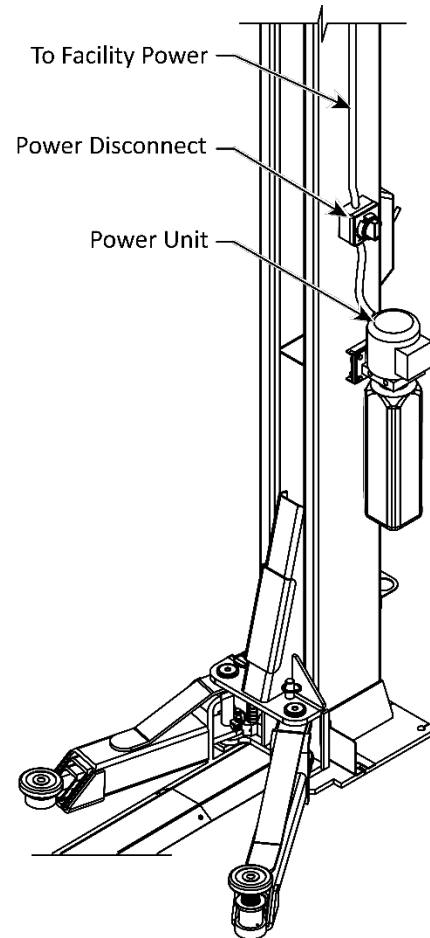

Installing a Thermal Disconnect

The Power Unit supplied with this Lift **does not** include thermal overload protection. Under NEC 430, UL 201, and CSA C22.2 No. 68, intermittent duty motors are not required to include thermal protection. Local electrical codes may vary, and other requirements may exist that the installing electrician will address, if required.

The Electrician is to supply and install an appropriate motor Thermal Disconnect or overload device if local electrical codes require it.

⚠ DANGER A licensed Electrician must install the Thermal Disconnect. Do not perform **any** maintenance or installation on the Lift without first verifying that main electrical power has been disconnected from the Lift and **cannot** be re-energized until all procedures are complete.

Leveling

Before operating your Lift, verify the Lift posts are perpendicular to the ground and the lift arms are level:

- **Lift Posts:** The posts **must** be the same distance apart at the top and at the bottom.

To make sure the posts are straight, measure the distance between the posts at one foot off the ground (you will need to move the lift arms out of the way) and near the top of the posts. The two measurements (**A** and **B** in the drawing below) must be the equal.

If the posts are not straight, shim them as required.

⚠ CAUTION Lift posts that are not straight or lift arms that are not level present a safety risk. Vehicles placed on the Lift will be less secure; they could fall and cause injuries or damage to the vehicle, the Lift, or personnel.

- **Lift Arms:** When the Lift posts are straight, verify the lift arms are level. To make sure they are level, raise them to the first locking position and put a level on the Pads.

Adjust the equalizing cables to correct any out of level condition. Determine which lift arm is low, then adjust the hex nut on the bottom of the threaded end of the equalizing cable until the lift arms are level. When the lift arms are level, raise the Lift and listen for the lift heads' stop blocks hitting the safety locks (there is a distinct thump). The thumps from each post should be simultaneous or close to it.

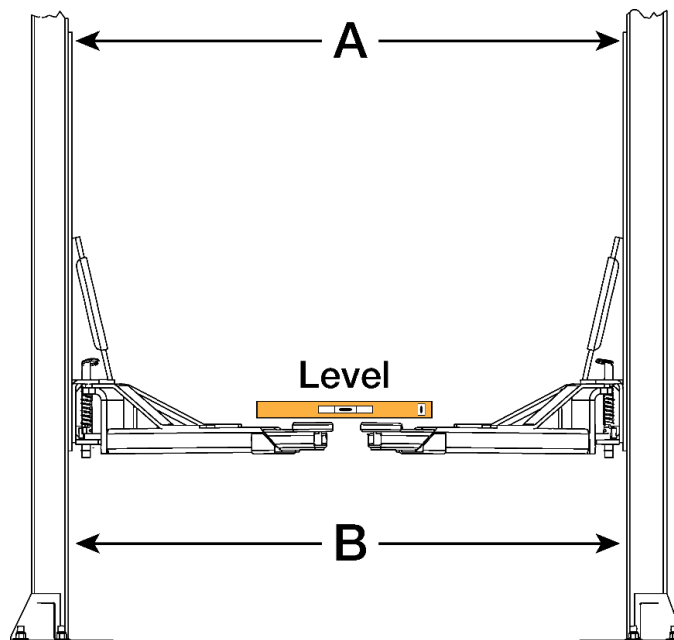

A and B distances must be the same.
If they are not, shim Posts until they are.

Pads must be level.
If they are not, adjust Equalizing Cables until they are.

Adjust Nut up or down to equalize Lift Heads and Pads

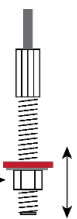

Installing the Safety Covers

There are two safety covers, one for each safety assembly, on the outside of each post. Both safety covers connect to their posts via M6 fasteners and nylock hex nuts.

To install the Safety Covers:

1. Locate the two safety covers and four M6 x 20 mm cover screws and nylock hex nuts.
2. On the off side lift post, slide the safety cover into position, then insert both cover screws and secure with the nylock hex nuts. Refer to the figure below.

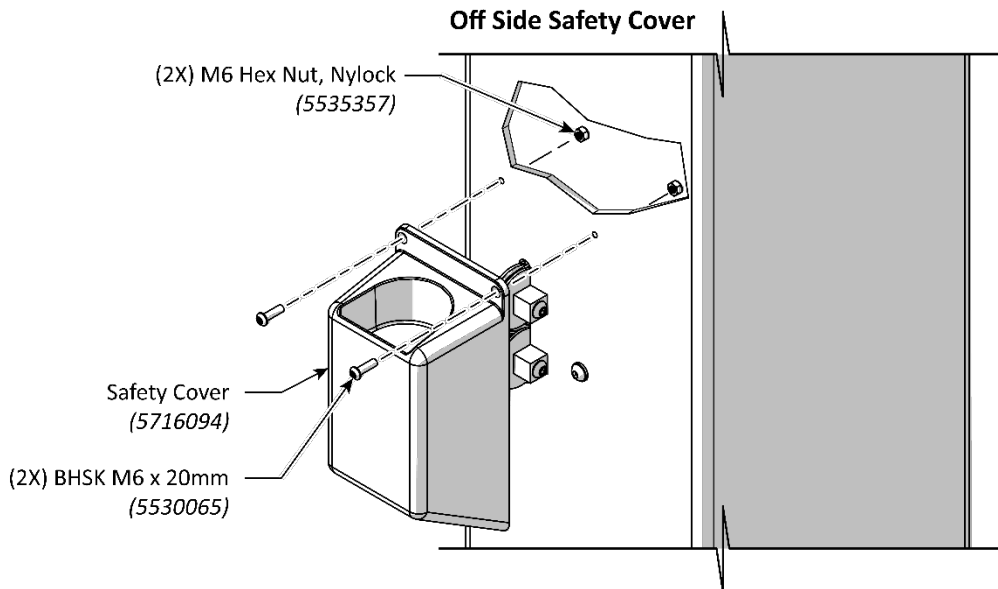

3. On the power side post, slide the safety cover into position, then insert both cover screws and secure with the nylock hex nuts. Refer to the figure below.

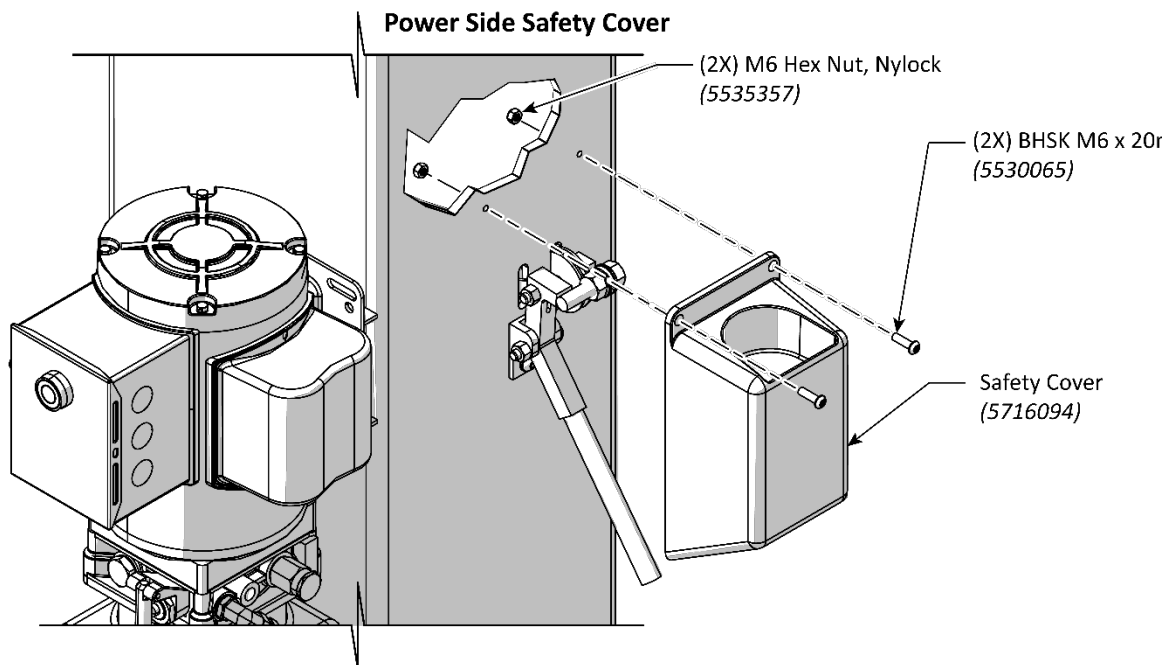

Lubricating the Lift

Your Lift will operate better and longer if the posts are lubricated regularly.

Lubricate the following on a monthly or as required basis:

- Lubricate the two bottom cable sheave bores and pins, and one top cable sheave bore and pin on both Lift posts. Lubricate with white lithium grease.
- Lubricate the four inside corners of both lift posts, with white lithium grease. Apply to all areas that contact the slide blocks.
- See [Wire Rope Inspection and Maintenance](#) for Wire Rope lubrication information.

Lubricate all four interior corners of **both** Lift posts top to bottom with white lithium grease. This is the travel zone for the lift head slide blocks.

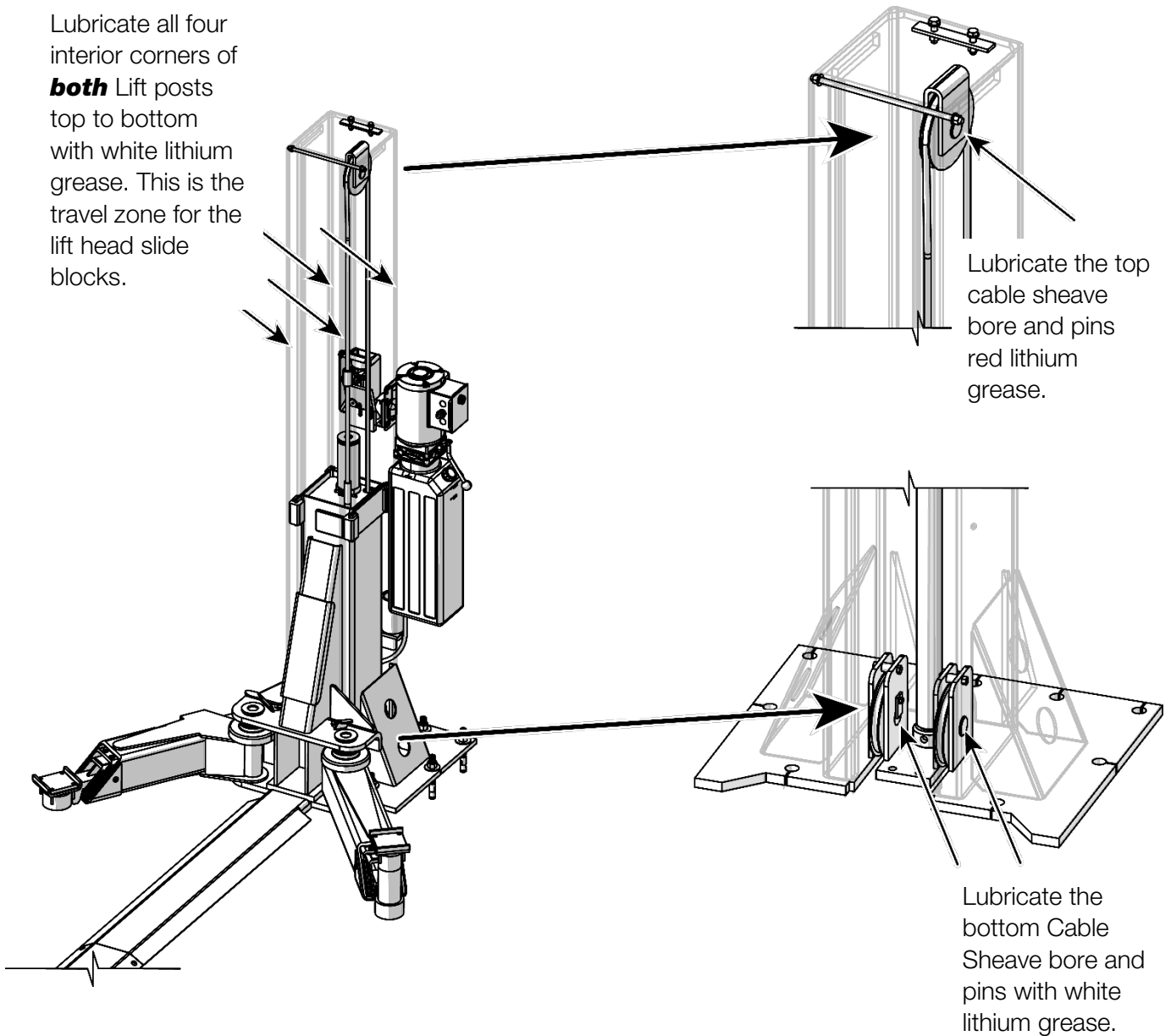

Install the Floorplate

The Floorplate protects the hydraulic hose, the equalizing cables, and the safety lock cable.

The **10AP-SRT** Floorplate Assembly consists of two sections bolted together. The assembly is mechanically captured between the Lift's base plates and requires no fasteners to the floor.

The **12AP-SRT** Floorplate Assembly consists of three sections bolted together. The assembly is mechanically captured between the Lift's base plates and requires no fasteners to the floor.

To install the Floorplate:

1. Retrieve the off side and power side floorplates.
2. Place as depicted in the figure below (*add the middle section for the 12AP-SRT installations only*).
3. Secure the floorplate assembly using M10 x 12 mm Button Head Socket Screws.

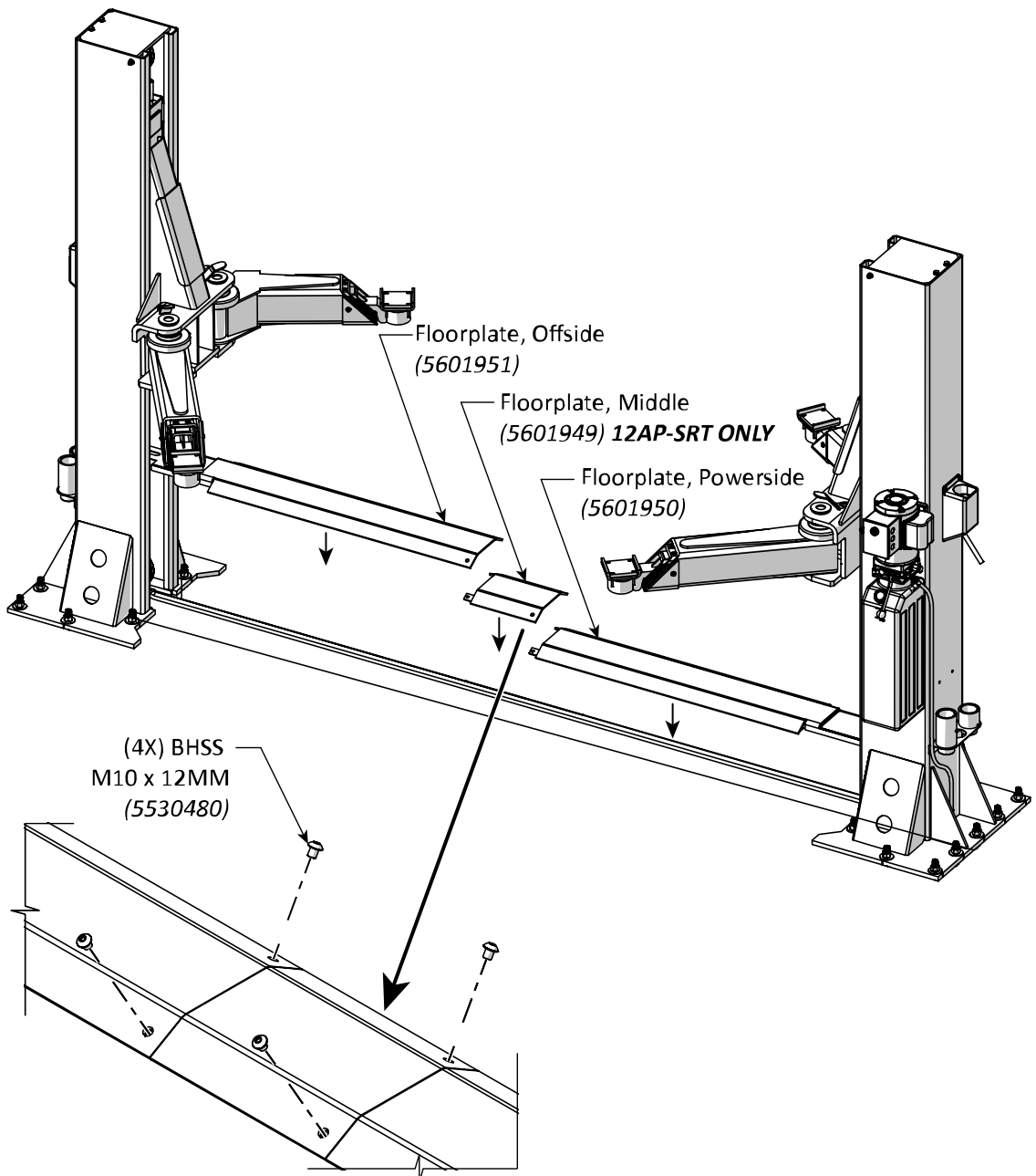

Perform an Operational Test

Before putting your Lift into normal operation, BendPak recommends raising and lowering it several times with a typical vehicle on the Lift. This will enable the operator to acquire a feel for operating the controls and help remove any residual air from the hydraulic system (self-bleeding).

 **DANGER** Automotive Lifts are dangerous tools when used by inexperienced or impaired technicians. When you even hear the words “automotive lift,” your brain should automatically register the fact that lifting a vehicle is a serious endeavor with life-threatening risks if mandatory lifting precautions are ignored.

During the operational test, check for proper installation and operation. Do not raise any additional vehicles until a thorough operational test has been done with a typical vehicle.

 **WARNING** **Never raise a vehicle whose weight exceeds the rated capacity of the Lift.** Do not leave the controls until the Lift is engaged on its safety locks. Only trained personnel should raise or lower the Lift.

To perform an Operational Test:

1. Follow the instructions in **Raising a Vehicle** (pg. 61) and **Lowering a Vehicle** (pg. 64) to safely raise and lower a vehicle on the Lift.

 **WARNING** Be sure to follow the instructions carefully when it comes to contacting the manufacturer’s recommended lifting points on the underside of the vehicle. If you do not, the vehicle could become unstable and fall, damaging the vehicle, the Lift, and injuring or even killing anyone under the vehicle.

2. Adjust the lift arms under the vehicle so the adapters are **directly under** the lifting points for the vehicle you are raising.
3. Raise the Lift until **just before** the pads contact the lifting points.
4. Check the Arm Restraint Gears on all four lift arms to verify they are engaged. If the restraints are not engaged, move the lift arms back and forth until they engage.

5. Raise the Lift until the tires of the vehicle are a few inches off the ground.

6. Check to verify all four adapters are making solid contact with the lifting points.

If any of the adapters are **not** making solid contact with the lifting points, carefully lower the Lift and start over again; the adapters **must** make solid contact with the lifting points.

7. Raise the vehicle approximately three feet (one meter) off the ground, then lower it back down.

Watch and listen as the Lift raises and then lowers. The Lift may move erratically or make some odd noises the first couple of times it is used; this is normal.



Tip

Residual air in the Hydraulic System can cause the Lift to shake, move erratically, or squeak; this is normal upon first use. These noises will soon stop, as air is bled from the system.

8. Wait for one minute between lifts.

NOTICE The power unit is not a constant duty motor; **it cannot be run continuously.**

9. Repeat the process, this time raising the Lift, engaging it on a safety lock position, taking it off the safety lock position, and then lowering it back down to the ground.

Again, follow the instructions in **Raising a Vehicle** and **Lowering a Vehicle** to safely raise and lower a vehicle on the Lift, including engaging it on its safety locks.

10. If the Lift is working without shaking, moving erratically, or squeaking, there is no need to repeat the procedure.

If the Lift is shaking, moving erratically, or squeaking, repeat the procedure one more time.

If you continue to have issues, refer to **Troubleshooting** for assistance.

11. When the Lift is on the ground and the vehicle is on all four tires, move the four lift arms to their full drive-through positions.

12. Drive the vehicle out when it is safe to do so.

Review Final Checklist Before Operation

Verify the items below have been completed before putting the Lift into normal operation:

- Review the **Installation Checklist** to make sure all steps have been performed.
- Verify the power unit is getting power from the power source.
- Check the hydraulic fluid reservoir; it must be full of approved hydraulic fluid or automatic transmission fluid. **You can damage the motor by running it without enough fluid.**
- Check the Hydraulic System for leaks. Verify all hydraulic hose connections, Hydraulic fittings, and Auxiliary Port Plugs on the Lift and power unit are tight.
- Verify the cylinder clamps are positioned at the top of the lift head and secured on **both** cylinders!
- Verify both posts are plumb, shimmed, and stable.
- Verify that all anchor bolts are correctly torqued.
- Apply white lithium grease to the inside of the posts where the slide blocks travel.
- Make sure both Threaded Rods are in place and tightened near the top of both posts.
- Verify all cables are properly positioned in their sheaves.
- Verify all cable sheave retaining pins and/or clips are secure.
- Verify both Safety assemblies are connected and working normally.
- Verify that all safety locks are clear and free.
- Verify the cylinder clamps are secured above the lift head on **both** Lift posts.
- Make sure a successful operational test has been done.
- Leave the *Installation and Operation Manual* with the owner/operator.



Operation

This section describes how to operate your Lift.

 **DANGER** Automotive Lifts are dangerous tools when used by inexperienced or impaired technicians. When you even hear the words “automotive lift,” your brain should automatically register the fact that lifting a vehicle is a serious endeavor with life-threatening risks if mandatory lifting precautions are ignored.

Lift Operation Safety Rules

Important: Your safety is dependent on reading, understanding, and implementing these Safety Rules. **Do not skip over them; read them carefully and follow them!**

Do the following before you raise or lower a vehicle on your Lift:

- **Check the Lift.** Check the Lift for any missing, heavily worn, or damaged parts. Do not operate the Lift if you find any issues; instead, take it out of service, contact your dealer, email support@bendpak.com, or call **(800) 253-2363**, select option 7, then 4.
- **Check the area.** Keep the area around the Lift clean and free of obstructions; anything that could cause a problem for the Lift. Do not forget to check **above** the Lift. If you find an obstruction, move it out of the way. Do not allow any people or animals within 30 feet of the Lift while it is in motion.
- **Check the operators.** Make sure that everyone who is going to operate the Lift has been trained in its use, has read the labels on the unit, and has read the manual. Only the operator should be within 30 feet of the Lift when it is in motion. Do not allow children to operate the Lift. Do not allow anyone under the influence of drugs or alcohol to operate the Lift.
- **Check for safety.** Make sure everyone who is going to be walking near the Lift is aware of its presence and takes appropriate safety measures. Only put vehicles on the lift arms. **When raising a vehicle on the Lift, do not leave it until it is positioned on safety locks.** When lowering the Lift, do not leave it until it is on the ground.
- **Check the vehicle.** Never exceed the Lift’s weight rating. Do not allow people inside the vehicle you are going to raise. Make sure the vehicle is not overbalanced on either end. Make sure you know the manufacturer’s recommended lifting points for the vehicle. Never raise just one side, one corner, or one end of a vehicle.

 **WARNING** Always use care when you are around your Lift. When it is in a lowered position, be careful not to trip over it. When it is raised, be careful not to strike your head on the lift arms or the vehicle. **When you are raising or lowering a vehicle, keep all people, animals, and objects at least 30 feet away from the Lift.**

About Lifting Points, Adapters, and Auxiliary Adapters

When using a frame-engaging Lift is critical that the raised vehicle must be balanced on the four lift arms. If the vehicle is not balanced, it is more likely to become unstable and slide off the Lift, damaging the Lift, the vehicle, and anything under the Lift, including injuring people.

⚠ WARNING You **must** use all four lift arms when raising a vehicle. Never use just one, two, or three lift arms to raise a vehicle. The vehicle will be unstable and could slip off the Lift, damaging the Lift, damaging the vehicle, and injuring anyone under it.

To balance a vehicle on a frame-engaging Lift, you need to have the adapters (also called Pads) contact the vehicle on the manufacturer's recommended lifting points. When you raise a vehicle by its lifting points, the vehicle is balanced.

NOTICE The manufacturer's recommended lifting points do not take into consideration any major changes that might have been made to the vehicle. If the motor is removed, for instance, or there is a 5,000 pound / 2,268 kg weight in the trunk, the vehicle's lifting points will not be the best balancing points.

Some vehicles have indicators on the underside that identify the lifting points; many do not.

Your best approach is to find the vehicle in the **ALI guide**, *Vehicle Lifting Points for Frame Engaging Lifts* or contact the manufacturer of the vehicle. This guide also includes a page of safe lifting suggestions, which everyone who uses this Lift should read. *Lifting it Right: A Safety Manual from the Automotive Lift Institute*, also available through **ALI**, includes a wide variety of information about Lifts and how to use them safely.

⚠ DANGER **Never** place contact pads on non-approved, non-load holding Sill Covers or Side Skirts!

10AP-SRT Standard Accessories Supplied

- **Four Round Screw Lift Pad Assemblies** (5215704) Best suited for vehicles with Unibody construction; they are height adjustable, up to 2.25 in. (55mm).
- **Two Height Adapter Holders** (5701660) Adapter Holders allow storage of auxiliary adapters conveniently near the lift arms.

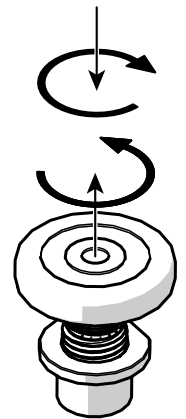

10AP-SRT Optional Accessories

The following optional accessories are not included with the Lift. Visit bendpak.com to order.

⚠ WARNING Use the correct Adapters. Do not attempt to lift trucks or other frame type vehicles with standard rubber contact pads.

⚠ WARNING Never use the Lift with missing or damaged rubber contact pads. Always replace Rubber contact pads when worn or damaged.

- **Quick-Fit Slotted Pinch-Weld Pucks or Pads** — Always use slotted Pinch-Weld Pucks (5210263) or slotted Pinch-Weld Pads (5210254) when lifting vehicles on manufacturer approved pinch-weld Jacking Points. These convenient tear-resistant urethane Adapters simply fit over the existing round contact pads.

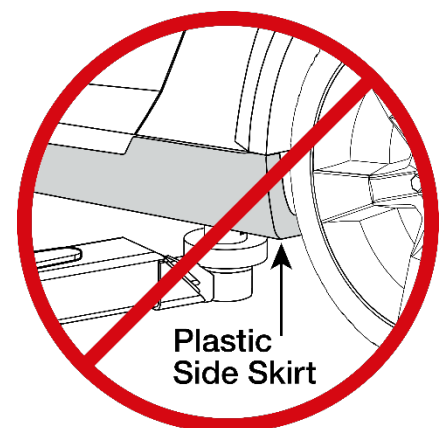

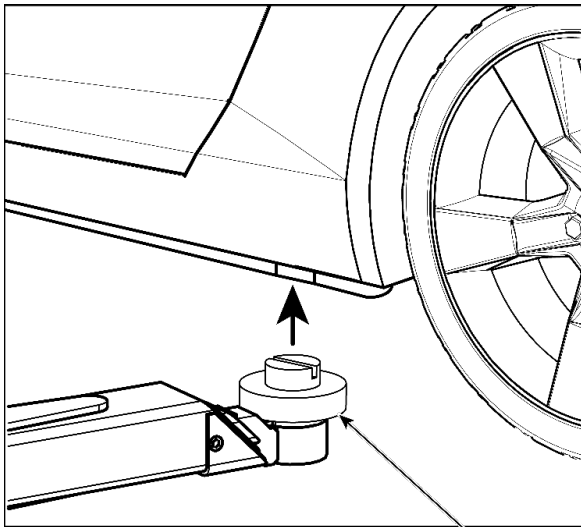

✓ Always use slotted Pads or Pucks when lifting Vehicles on OEM-approved Pinch Weld Jacking Points.

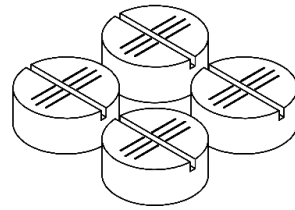

5210254 Set of 4 Slotted Pads

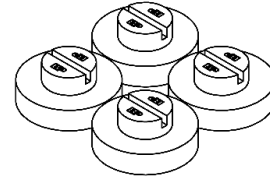

5210263 Set of 4 Slotted Pucks

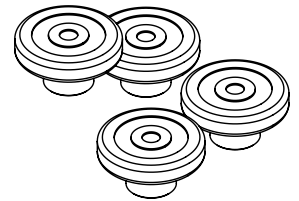

- **Lift Pad Assembly** — Fixed type (non-screw) Lift Pad assemblies are a drop-in replacement (5215760). Set of four.

12AP-SRT Standard Accessories Supplied

⚠ WARNING Use the correct Adapters. Do not attempt to lift trucks or other frame type vehicles with standard rubber contact pads.

⚠ WARNING Never use the Lift with missing or damaged rubber contact pads. Always replace Rubber contact pads when worn or damaged.

- **Four Drop-in Frame Cradle Pads** (5215761). Required for use when lifting trucks, vans or other frame vehicles that require additional stability.
- **Four Medium Auxiliary Adapters - 2.5 in. (63 mm)** (5746192). Allows you to position the height of your auxiliary adapters to make better contact with vehicles.
- **Four Tall Auxiliary Adapters - 5 in. (125 mm)** (5746193). Allows you to position the height of your auxiliary adapters to make better contact with vehicles.

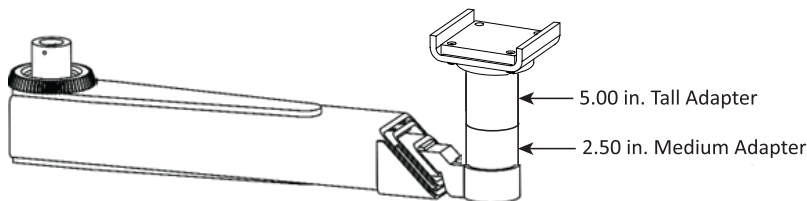
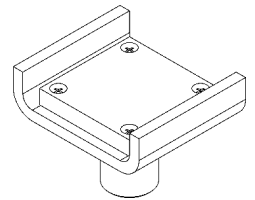

- **Two Height Adapter Holders** (5701660) Adapter Holders allow storage of auxiliary adapters conveniently near the lift arms.

⚠ WARNING You may stack the optional auxiliary adapters, **but only up to 9 in.** If you stack auxiliary adapters above 9 in., the vehicle could become unstable and slip off the Lift, damaging the Lift, damaging the vehicle, and injuring anyone under it.

12AP-SRT Optional Accessories

The following optional accessories are not included with the 12AP-SRT Lift. Visit [bendpak.com](https://www.bendpak.com) to order.

⚠ WARNING Use the correct Adapters. Do not attempt to lift trucks or other frame type vehicles with standard rubber contact pads.

⚠ WARNING Never use the Lift with missing or damaged rubber contact pads. Always replace Rubber contact pads when worn or damaged.

- **SUV and Van Adapters** — Recommended for Trucks, SUVs, and Vans requiring additional lifting height.

56 mm (5746007)

63 mm (5746192)

125 mm (5746193)

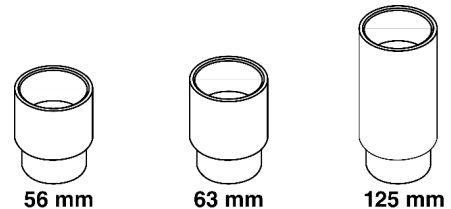

⚠ WARNING Use the correct Adapters. Do not attempt to lift trucks or other frame type vehicles with standard Rubber Contact Pads.

- **Wide Frame and Super Wide Frame Cradle Adapters** — Recommended for use when lifting heavy-duty wide frame vehicles.
 - **Wide Frame** version fits frames up to 5.25 in. (133 mm) (5215828) wide, Set of 2.
 - **Super Wide Frame** version fits frames up to 6.5 in. (168 mm) (5210253) wide, set of 2.

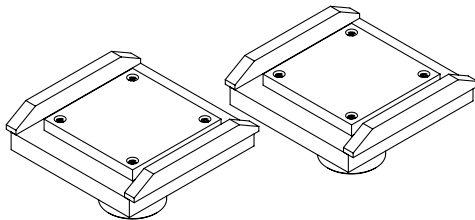

Wide Frame Cradle Adapter

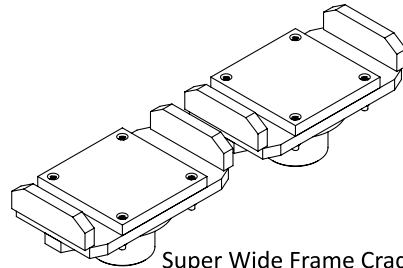

Super Wide Frame Cradle Adapter

- **Cradle Lift Pad** — Wide Polyurethane Pad, set of 4 pads (5210231).

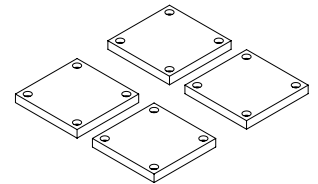

- **Steel Lift Pads** — Recommended for additional stability on all vehicles. The flanged edges grip the chassis for an extra-secure hold. (5215692)

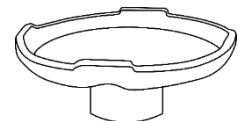

You may contact BendPak for accessories and replacement Parts information at **(800) 253-2363**, press option 7, then 5; please have the model and serial number of your Lift available. Visit [bendpak.com](https://www.bendpak.com) for additional Adapters and Auxiliary Adapters (also called height adapters or extenders).

Raising a Vehicle

This section describes how to safely raise a vehicle on your Lift.

⚠ WARNING Never raise a Vehicle whose weight exceeds the rated capacity of the Lift. Do not leave the controls until the Lift is engaged on a Safety Lock position or fully lowered. Only trained personnel should raise and lower the Lift.

⚠ WARNING Always stay within the Safe Operator Area when using the Lift. Refer to the figure below. The safe operator area will keep the operator clear of crushing, shear and pinch points while providing an unobstructed line of sight to the vehicle and access to the Lift Controls. Personnel near the Lift but outside of the Safe Operator Area should be moved clear of the lift by a minimum of 30 ft. (9 m).

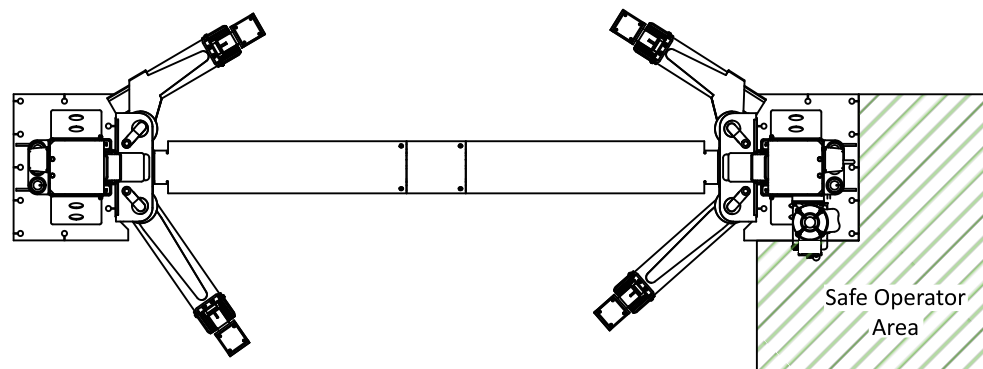

To raise a vehicle on the Lift:

1. Verify all four lift arms are on the ground in their full drive-through positions.
2. Check under the vehicle to be raised, check for the type of vehicle frame, and then use the most appropriate pads and adapters on the lift arms.

If you are lifting a sedan or a vehicle with a unibody construction, a screw lift pad is generally the best choice. If you are lifting an SUV, truck, or other vehicle with a frame construction, a Frame Cradle Pad is generally the best choice.

⚠ WARNING Always use the adapter type best suited for the vehicle you are raising. If the wrong adapter type is used, the vehicle could become unstable.

3. Drive the vehicle in.

⚠ CAUTION When driving a vehicle into position, keep to the middle of the area between the posts. If you hit a Lift Arm or any other portion of the Lift, you could damage the vehicle and/or the Lift.

4. When you are satisfied with the location of the vehicle, put it in park, set the parking brake, and turn off the motor.

If the vehicle is a manual transmission, put it into first gear before turning off the motor.

5. Get out of the vehicle; open the doors carefully to avoid striking them on the Lift.
6. Locate the manufacturer's recommended lifting points for the vehicle you are raising.

If you are unsure where the lifting points are, consult *Vehicle Lifting Points for Frame Engaging Lifts*, which is available through ALI at www.autolift.org/ali-store/, or the manufacturer of the vehicle.

Some vehicles may have the manufacturers' recommended Service Garage Lift Point locations identified by a triangle mark on the underside of the vehicle, reference SAE J2184- (Current Edition). On some vehicles, specific lifting points are indicated by a label located on the driver's side door jamb.

⚠ WARNING Do not 'eyeball' the best location for the adapters. **You must use the manufacturer's recommended lifting points.** If you do not, the vehicle could become unstable and fall, which could damage the vehicle, damage the Lift, or injure or even kill anyone under the vehicle.

⚠ WARNING Many specialty or modified vehicles or vehicles with unusually short or long wheelbases cannot be on raised on a Two-Post Frame Engaging Lift. Contact the vehicle's manufacturer for Lifting or Jacking guidance.

The figure on the next page illustrates typical lifting points based on vehicle Frame type.

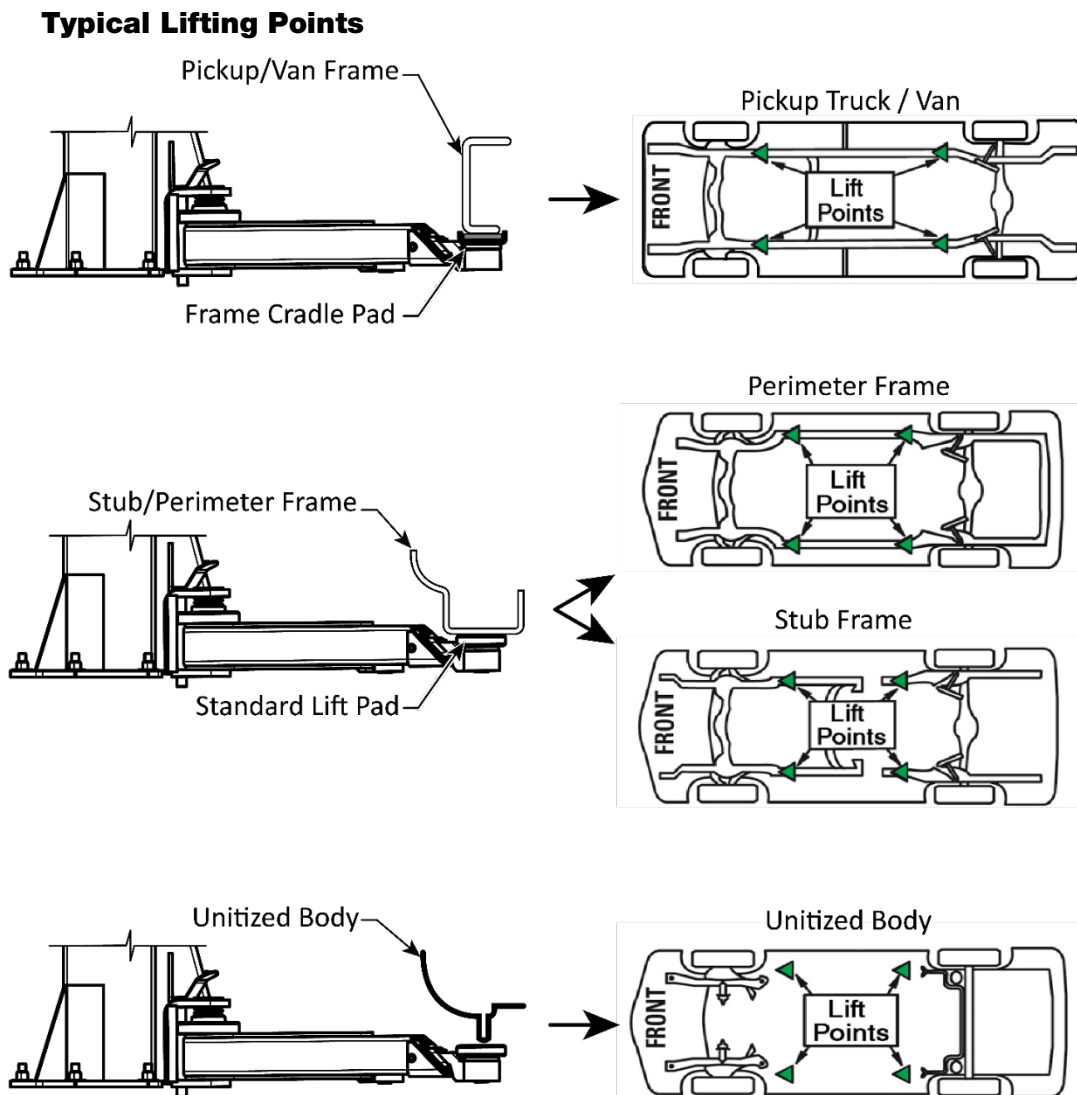

 **WARNING** Before attempting to lift a vehicle verify:

- The vehicle frame is strong enough to support its weight and has not been weakened or compromised by modification, damage, or corrosion.
 - The vehicle individual axle weight does not exceed one-half the Lift capacity.
 - The Lift adapters are in secure contact with the Frame at the vehicle manufacturers' recommended Lift Points.
 - The vehicle is stable on the Lift and the center of gravity is not shifted making the vehicle off balance.
7. Adjust the lift arms under the vehicle so the adapters are **directly under** the lifting points for the vehicle you are raising.
- If necessary, use optional auxiliary adapters for extra height.
8. Raise the Lift until **just before** the adapters contact the lifting points.
9. Check the Arm Restraint Gears on all four lift arms to make sure they are engaged. If they are not engaged, move the lift arms back and forth until they engage.
10. Raise the Lift until the tires of the vehicle are a few inches off the ground.
11. Check to make sure all four adapters are making solid contact with the lifting points. If any of the adapters are **not** making solid contact with the lifting points, carefully lower the Lift and start over again; the adapters **must** make solid contact with the lifting points.
12. Rock the vehicle to verify the vehicle is stable and balanced. If the vehicle is **not** stable and balanced, lower the Lift back to the ground and start over. If the vehicle **is** stable and balanced, you can raise it to the desired height.

 **DANGER** Do not raise the Lift further until you are certain the vehicle on the Lift is both stable and balanced. If the vehicle is **not** stable and balanced, it could fall, which could damage the vehicle, damage the Lift, or injure or kill anyone under the vehicle.

13. Press and hold the **Up** Button. Listen as the Lift passes the safety locks; you should hear each side pass by the safety locks at approximately the same time.
14. When the vehicle reaches the desired height, go past the next safety lock position (you will hear the clank as it passes), then release the **Up** Button.
15. Press and hold the Lowering Handle. The Lift will lower onto the safety lock you just passed. Do **not** hold the safety lock release handle; that is for lowering the Lift to the ground.
16. When the Lift stops moving down, it is engaged on its safety locks; release the Lowering Handle.
- Do not leave the Lift controls unless the Lift is engaged on its safety locks or fully lowered.**
17. Recheck the adapters to verify they are all still making solid contact with the lifting points.
18. Make sure the Lift is engaged on the same safety lock on both posts. If the Lift is engaged on safety locks of two different heights the vehicle may become unstable.
19. Begin working on the vehicle if the Lift is safe in all respects.

 **DANGER** Only leave the Lift fully lowered or engaged on its safety locks. Never move or work under a vehicle unless it is stable and resting on the safety locks.

To raise Lift:

1. Press and hold Up Button.
2. When Lift is just past desired height, release Up Button.
3. Press and hold Lowering Handle.

Do not pull down the safety lock release handle. If you do, the Lift will continue to lower and will not engage on its safety locks.

Lift engages on its safety locks and stops moving; release Lowering Handle when Lift stops.

Only leave Lift on safety locks or fully lowered.

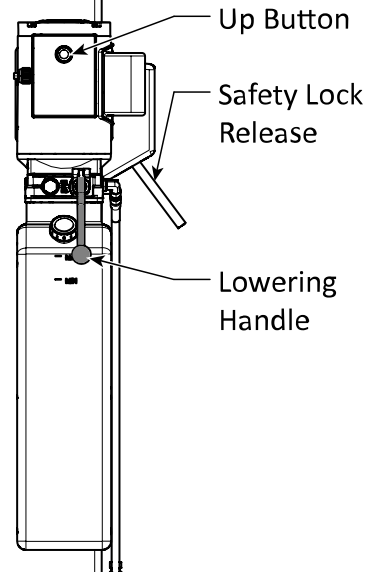

To lower Lift:

1. Press and hold Up Button for two to three seconds. This moves Lift off its safety locks.
2. Pull down and hold safety lock release handle **and** Lowering Handle. Lift begins lowering.
3. When Lift is fully lowered, release safety lock release handle and Lowering Handle.

Only leave Lift on safety locks or fully lowered.

Lowering a Vehicle

To lower a vehicle off the Lift, first raise it a small amount to get it off its safety locks, then lower it.

To lower a vehicle off the Lift:

1. Check under and around the vehicle to verify the area is clear of all obstructions. If you find any obstructions, move them out of the way.
2. Press and hold the **Up** Button for a second or two to move the Lift off its safety locks. Raise the Lift at least two inches to clear the safety locks.
3. Pull down and hold the safety lock Release, while pushing and holding the Lowering Handle (on the front of the Power Unit). The Lift will begin to lower.

Important: Both the safety lock Release **and** the Lowering Handle must be held down at the same time to lower the Lift.

WARNING

Do not override the Lift controls; for safety purposes, they are designed to stop the Lift if released. Overriding the Lift controls could damage to the Lift, damage the vehicle on the Lift, or injury (even death) to personnel near the Lift.

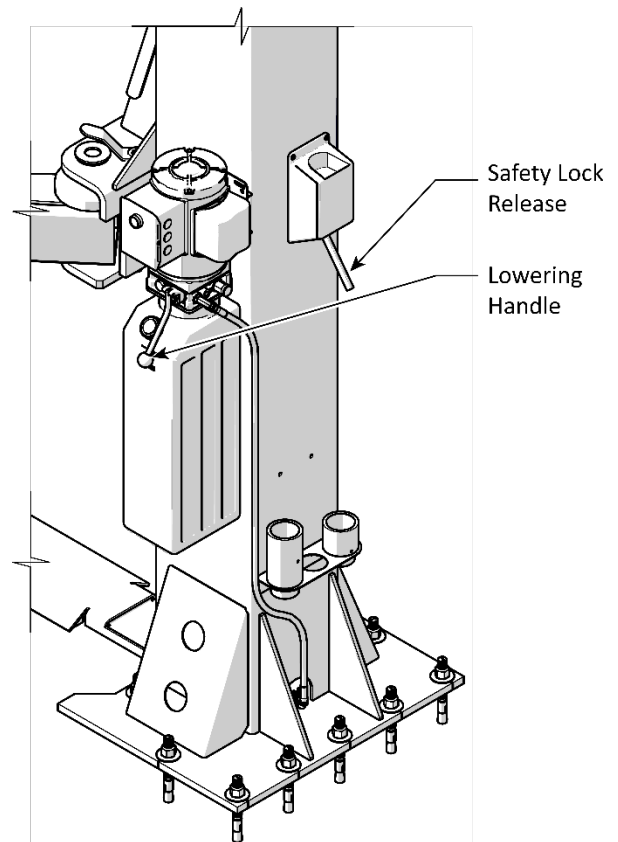

Remain clear of the Lift as it descends; obey the pinch point warning decals.

4. When the Lift is on the ground, release both Handles, then move all four lift arms to their full drive-through positions.
5. Drive the vehicle out.

About Safety Locks

This Lift includes eight safety lock positions, allowing the Lift to be positioned at the best height for the work required.

A safety lock **position** is defined as the Lift Head's Safety Stop Block engaged on the Lift Post's Safety Weldment. Both Lift heads must be engaged on the Safety Stop Block at the same height on both posts. Any other condition is considered and unlocked position.

Important: Always verify both safety locks are engaged at the same height on both posts. It is dangerous for the Lift to be engaged on safety locks of two different heights or to have the safety lock on one post engaged while the safety lock on the other post is not engaged.

Safety lock positions are created by the Safety Stop Blocks, which are welded on to the back of each lift head. The Safety Lock weldments move past the blocks as the lift heads rise.

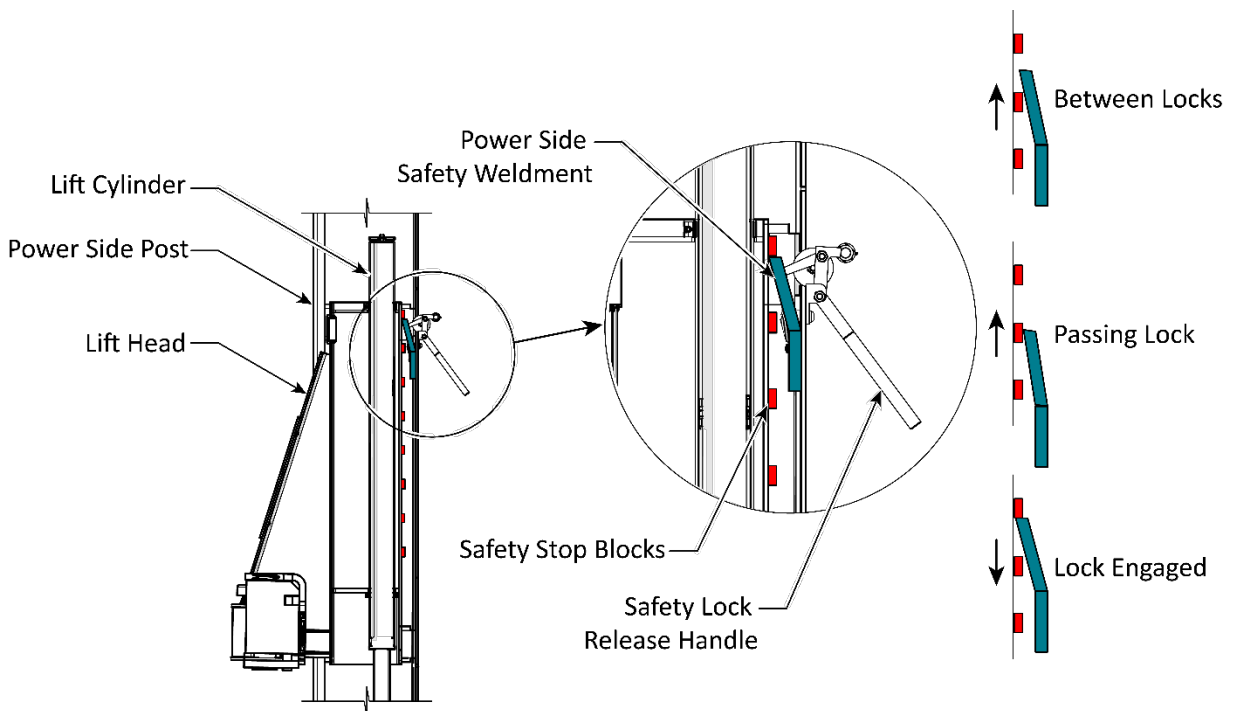

Drawing not to scale. Components removed for clarity. Off side safety lock not shown.

As they move past the safety locks, the weldments push the safety weldment and the safety lock release handle down (the safety lock release handle is found on the Power Side Post only). When the weldment is completely past the safety locks, the safety locks drop back into position between weldments. This happens each time the Safety Lock Weldments are passed by a Stop Block. An audible click is heard as the weldment drops between the Stop Blocks.

To engage the Lift on a safety lock position, raise the vehicle until it reaches the desired height for the work required, then listen for the clicks as the weldments pass the next safety lock position. When you hear the safety weldment click, release the Up Button, and then hold down to open the Lowering Valve

(on the front of the power unit) for a second or two to back the Stop Blocks down onto the Safety Weldments. **Do not** hold down the safety lock release handle while holding the down valve on the Power Unit open. This will bypass the Stop Blocks and return the vehicle all the way to the ground.



 **WARNING** Only leave the Lift either fully lowered or engaged on its Safety Locks. **If you leave the Lift raised but not engaged on safety locks, the vehicle is not secure.** It could fall, damaging the vehicle, the Lift, and injuring anyone near the vehicle.

Maintenance

 **DANGER** Before performing any maintenance on your Lift, verify it is completely disconnected from power. The Lift uses electrical energy; if your organization has Lockout/Tagout policies, make sure to implement them before performing any maintenance. If you come into contact with high voltage, you could be injured or killed.

 **DANGER** Do not use the Lift if the cables are damaged or extremely worn. If a Vehicle is raised when you notice the damage or extreme wear, very carefully lower the Vehicle to the ground. When the Lift is on the ground, remove it from service, disconnect it from power, and make arrangements for repair.

 **DANGER** Always wear proper Personal Protective Equipment (PPE) when working with hydraulics. Gloves and Safety Glasses are a minimum requirement. Keep your body away from suspected leaks. Use a clean piece of sheet metal to pass along hoses and fittings to detect leaks. Shut down the equipment if a leak is suspected or

 **WARNING** Do not operate your Lift if you find maintenance issues; instead, remove it from service and correct the maintenance issues. Technical support and service is available from your dealer, on the Web at bendpak.com/support, by email at support@bendpak.com, or by phone at **(800) 253-2363**, option 7 then 4. Online chat is also available at www.bendpak.com click the chat icon. 

Read the Installation and Operation manual and understand how this equipment operates before using, maintaining, or repairing. Routine maintenance and adjustments are the responsibility of the owner/user and are not covered under warranty.

Routine maintenance and adjustments should be carried out on a regular basis as outlined below. *Unless stated otherwise, all maintenance may be performed by the owner/employer and does not require trained lift service personnel.* Replace worn, damaged or broken parts with original BendPak or BendPak approved parts or with parts that meet or exceed the original specifications.

Maintenance and Interval Recommendations:

This lift's service life is dependent on the level and frequency of care and maintenance you provide. By simply following a few guidelines, you can increase the life of your lift by many years. The following care and maintenance procedures not only help to foster that, but also aid by ensuring safe operation and early detection of problems.

Tools required:

- Open End Wrench Set (SAE & Metric)
- Screwdrivers (Phillips and Slotted)
- Hydraulic Fluid (same type and weight as the current fluid in use.)
- Clean Shop Towels
- Hex Key Set
- Lubricants
 - White Lithium Multi-Purpose Lubricant
 - Red Lithium Grease
 - ALMASOL Wire Rope Lubricant or 90W Gear Oil

The following maintenance and interval recommendations are based on typical workday use and operation.

Daily Maintenance

1. Keep the Lift and work area clean, to promote both safety and better problem visibility.
2. Visually inspect that the Safety Locks and controls are in good operating condition. Do not use your Lift if the Safety Locks or controls are damaged or excessively worn.
3. Check the Hydraulic Fluid Level in the Reservoir. Add fluid, if necessary.
4. Check for hydraulic fluid leaks on hoses, fittings, and cylinders. Inspect for damage. Hose covers that are cut, cracked, blistered, show signs of abrasion, kinking or flattened are to be replaced. Cylinder ports that are cracked, show signs of leaking or other damage.
5. Start the hydraulic system and lift the arms slightly to apply pressure. Pass a clean piece of sheet metal near the hydraulic hoses, fittings, and cylinders. Hydraulic fluid on the metal indicates a leak. Shut down the system and tagout the Lift to prevent use until repaired.
6. Verify the cylinder clamp is in place and tight on the hydraulic cylinder just above the Lift head.

Monthly Maintenance

1. Remove, clean, and apply new Red Lithium grease to all Cable Sheave Pins as outlined in the Lubrication Procedure.
2. Inspect the condition of all Equalizing Cables and mechanisms. Run a shop towel over the Cable surface while watching for snags. Replace as required.
3. Inspect all hydraulic hoses, fittings, and cylinders for damage and leaks.
4. Apply 90-WT gear oil or ALMASOL® Wire Rope Lubricant to both Equalizing Cables.
5. Apply White Spray Lithium Multi-Purpose grease to the four inside contact corners of both Posts.
6. Apply White Spray Lithium Multi-Purpose grease to all Lift Arm Pivot Points.
7. Inspect all Lift Arm Pins and locking mechanisms for damage and wear. Replace as required.
8. Verify all fasteners are torqued to specifications.
9. Verify all Warning labels are in good condition and legible.

Every Two Months

Verify all anchor bolts are secure and torque to 85-95 ft.-lbs.

Every three to five years or as required

1. Carefully check the Equalizing Cables for signs of damage or extreme wear. See **Wire Rope Inspection and Maintenance** for additional information.
2. Inspect and lubricate the Wire Rope, Sheaves and Pins.

If the Lift becomes inoperative in a raised position, refer to the **Troubleshooting** section.

 **WARNING** Do not operate your Lift if you find maintenance issues; instead, remove it from service, then contact your dealer or BendPak Support via the Web at bendpak.com/support, via email at support@bendpak.com, or by phone at **(800) 253-2363** select option 7, then 4.

Lubrication Procedure

See [Wire Rope Inspection and Maintenance](#) for Wire Rope lubrication information.

Lubricate all four interior corners of **both** Lift posts top to bottom with white lithium grease. This is the travel zone for the lift head slide blocks.

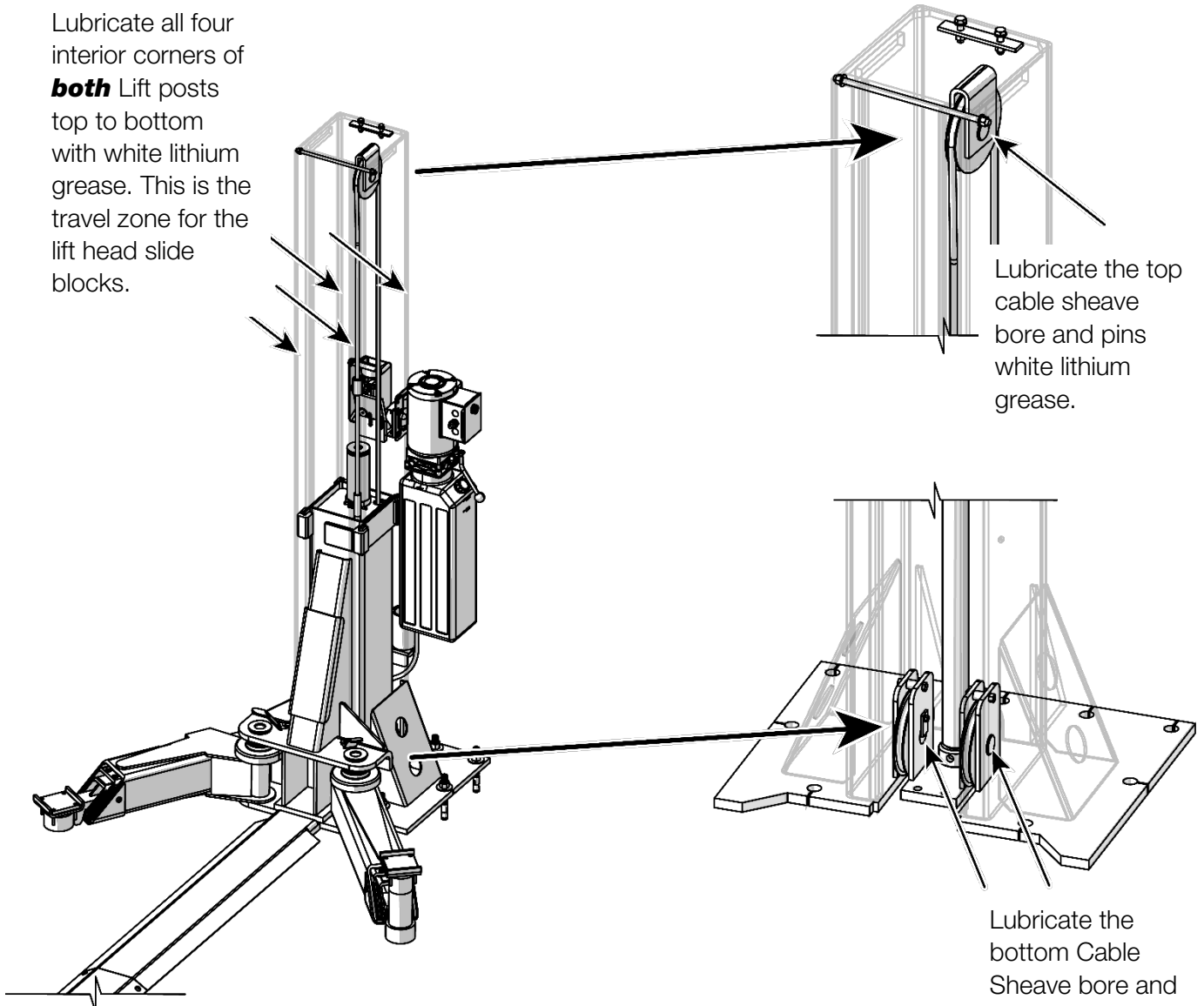

To Lubricate the Cable Sheaves:

1. Raise the Lift Head to rest on at least the first Safety Lock.
2. Block the Lift head with a 4 x 4 or equal to ensure the Lift Head cannot descend while lubricating the Lift.
3. Remove the Polyethylene Cover from the Lift Head then loosen the Cable Nut to relax the cable.
4. Lubricate the top Cable Sheaves.
 - a. Remove locking bolt securing the top cable Sheave Pins.
 - b. Remove the Pin from the Sheaves.
 - c. Apply Red Lithium Grease to the Pin and the sheave bearing.
 - d. Reinstall the Sheave Pins through the Sheave then secure with the locking bolt removed in step 4a.

To Lubricate the Bottom Cable Sheaves:

5. Remove the locking bolt.
6. Remove the Sheave Pin.
7. Lubricate the Pin and Sheave bearing with Red Lithium Grease.
8. Replace the Pin in the Sheave and secure with the locking bolt.
9. Tighten the Equalizing Cable adjustment in the Lift Head. See **Leveling** to readjust the Lift Arms.
10. Replace the Polyethylene Cover after leveling the Lift Arms.

To Lubricate the Inside of the Lift Posts:

11. Spray the inside corners of the Lift Post with White Lithium Grease. The corners are the contact area for the Slide Blocks on the Lift Head.

To Lubricate the Safety Cable Sheaves and Rollers:

12. Spray the Safety Cable Sheaves with white lithium grease.
13. Spray white lithium grease on all Safety Sheaves and Rollers.
14. Operate the Safety Cable several times to disperse the lubricant and verify smooth operation.
15. Raise the Lift Heads and remove any blocking lumber or jack stands.
16. Operate the Lift up and down several times to disperse the lubricant and verify operation.

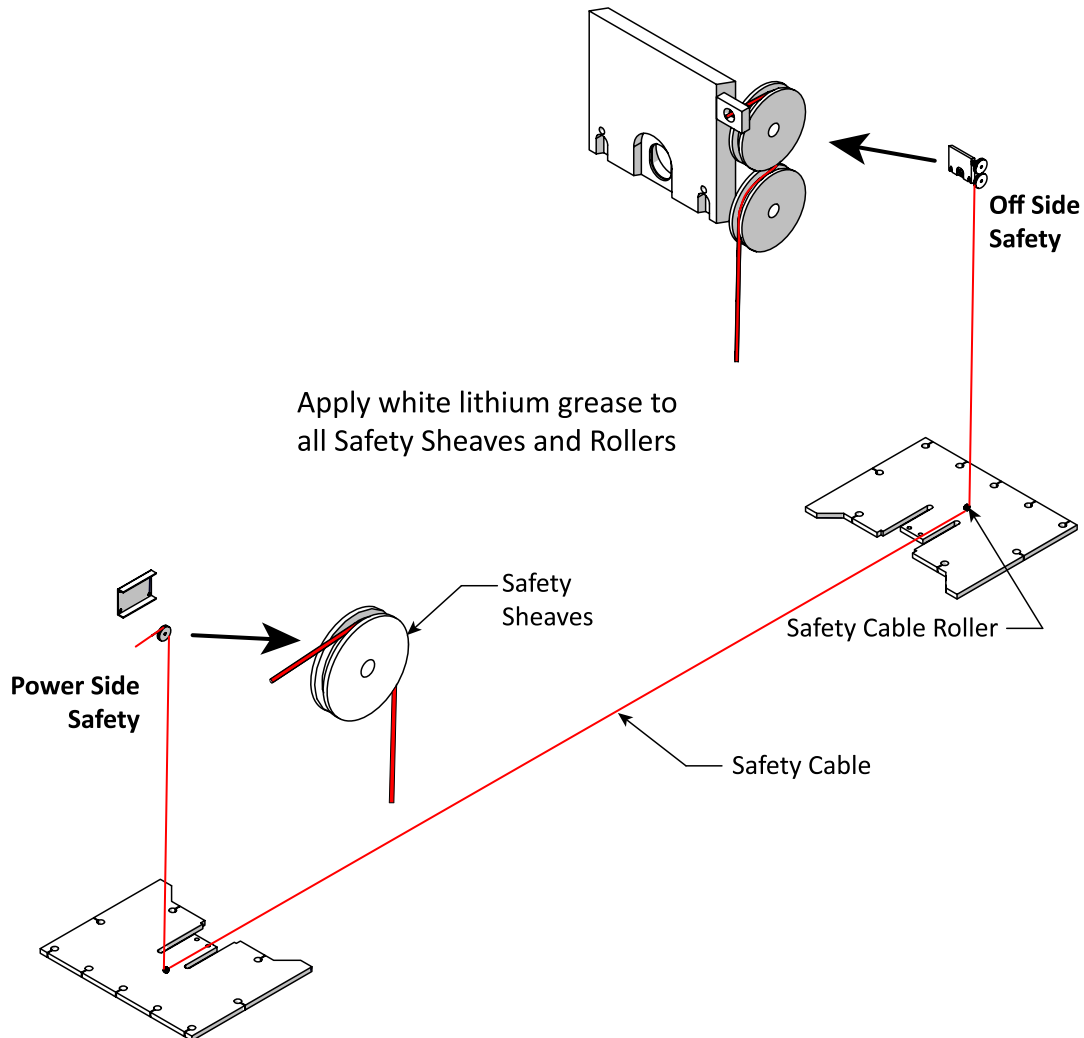

Wire Rope Inspection and Maintenance

Your Lift's wire rope should be inspected regularly:

- Lifting cables should be replaced when there are visible signs of damage or extreme wear. **Do not use the Lift if it has damaged or worn cables.**
- Lifting cables should always be maintained in a well-lubricated condition.

Wire rope is fully protected when each wire strand is lubricated both internally and externally. Excessive wear shortens the life of wire rope. Use a wire-rope lubricant that penetrates to the core of the rope and provides long-term lubrication between each individual strand, such as 90-WT gear oil or ALMASOL® Wire Rope Lubricant.

To make sure that the inner layers of the rope remain well lubricated, lubrication should be carried out at intervals not exceeding three months during operation.

- All sheaves and guide rollers in contact with the moving rope should be given regular visual checks for surface wear and lubricated to make sure they run freely. This operation should be carried out at appropriate intervals, generally not exceeding three months during operation.

For all sheave axles, use standard wheel bearing grease. For all sheaves and/or guide rollers, use 90-WT gear oil or a similar heavy lubricant, applied by any method including pump/spray dispensing, brush, hand, or swabbing.

- How often should you inspect?

Lifting cables should be visually inspected at least once each day when in use, as suggested by American Petroleum Institute's Recommended Practice 54 guidelines. Any lifting cables that have met the criteria for removal must be immediately replaced.

- When should you replace lifting cables due to broken wires?

Lifting cables should be removed from service when you see six randomly distributed broken wires within any one lay length, or three broken wires in one strand within one lay length.

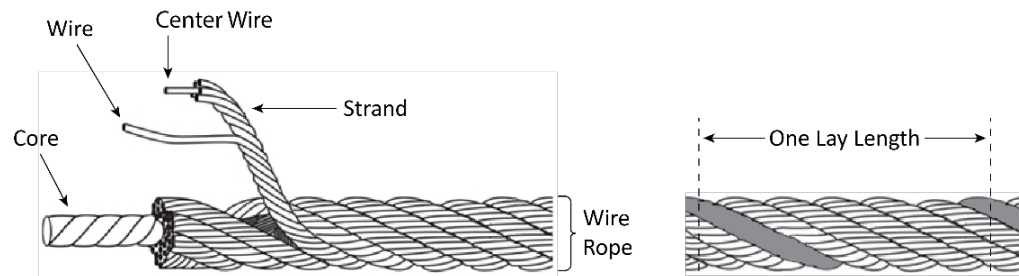

- Are there other reasons to replace your lifting cables?

Yes. Corrosion that pits the wires and/or connectors, evidence of kinking, crushing, cutting, bird-caging, or a popped core, wear that exceeds 10% of a wire's original diameter, or heat damage.

- How do you find broken wires?
 - a. Relax your rope to a stationary position and move the pick-up points off the sheaves. Clean the surface of the rope with a cloth — a wire brush, if necessary — so you can see any breaks.
 - b. Flex the rope to expose any broken wires hidden in the valleys between the strands.
 - c. Visually check for any broken wires. One way to check for crown breaks is to run a cloth along the rope to check for snags.
 - d. With an awl, probe between wires and strands and lift any wires that appear loose. Evidence of internal broken wires may require a more extensive rope examination.

Fastener Torque Chart

FASTENER TORQUE CHART														
Bolt Size (SAE)	Bolt Grade (SAE)	SAE Grade 0-1-2	SAE Grade 5	SAE Grade 8	Socket Head Cap Screw SAE Grade	Tightening Torque			Tightening Torque			Tightening Torque		
						Lubricated (ft.-lbs)	Zinc Plated (ft.-lbs)	Plain & Dry (ft.-lbs)	Lubricated (ft.-lbs)	Zinc Plated (ft.-lbs)	Plain & Dry (ft.-lbs)	Lubricated (ft.-lbs)	Zinc Plated (ft.-lbs)	Plain & Dry (ft.-lbs)
Bolt Size (Metric)	Bolt Class (Metric)	Metric Class 4.6	Metric Class 8.8	Metric Class 10.9	Metric Class 12.9	Tightening Torque			Tightening Torque			Tightening Torque		
Bolt Size (SAE)	Bolt Size (Metric)	Lubricated (ft.-lbs)	Zinc Plated (ft.-lbs)	Plain & Dry (ft.-lbs)	Lubricated (ft.-lbs)	Zinc Plated (ft.-lbs)	Plain & Dry (ft.-lbs)	Lubricated (ft.-lbs)	Zinc Plated (ft.-lbs)	Plain & Dry (ft.-lbs)	Lubricated (ft.-lbs)	Zinc Plated (ft.-lbs)	Plain & Dry (ft.-lbs)	
1/4-20	M6 x1.0	2.3	2.6	3.0	5.8	6.6	7.7	8.3	9.4	11.1	9.7	11.0	13.0	
5/16-18	M8 x 1.25	3.8	4.3	5.0	9.7	11.0	13.0	13.9	15.8	18.5	16.3	18.4	21.7	
3/8-16	M10 x 1.50	10.8	12.3	14.4	27.9	31.6	37.2	39.9	45.2	53.2	46.7	52.9	62.2	
7/16-14	N/A	24.0	27	30.0	35.0	42	50.0	55.0	59	70.0	61.0	68	76.0	
1/2-13	M12 x 1.75	18.9	21.4	25.2	48.7	55.1	64.9	69.6	78.9	92.8	81.4	92.2	108.5	
9/16-12	M14 x 2.00	30.2	34.2	40.2	77.8	88.1	103.7	111.3	126.1	148.4	130.0	147.4	173.4	
5/8-11	M16 x 2.00	47	53	62	121	137	161	173	196	230	202	229	269	
3/4-10	M18 x 2.50	65	73	86	167	189	222	239	270	318	279	316	372	
7/8-9	M22 x 2.50	136	155	182	320	365	430	460	515	600	510	575	640	

WARNING! Prior to installation, inspect all accompanying manuals, parts lists and catalogs to ensure you have all the necessary parts. Identify all fasteners and their proper torque settings as illustrated on this chart. Proper torquing practices cannot be over emphasized. Torque values are provided as a convenient method of achieving correct pre-loading of highly stressed fasteners. If the fasteners are not properly plated, the fastener threads are not clean and free of deformation, or are not properly lubricated, the correct fastener pre-load will not be achieved even though the given torque value is reached. For this reason, it is critical that all fasteners be inspected for proper plating, thread form and correctly lubricated prior to torquing. Failure to verify a fastener's serviceability or to correctly lubricate the fastener prior to assembly and torquing will result in the fastener not being properly pre-loaded and subsequent failure of the fastener may occur. The torque values can only be achieved if the nut (or tapped hole) has a proof load greater than or equal to the bolt's minimum ultimate tensile strength. Clamp loads estimated as 75% of proof load for specified bolts. Torque values are listed in foot-pounds. Torque wrenches should be calibrated on an annual basis. Never use an impact driver on a torque multiplier.

Troubleshooting

This section describes how to troubleshoot your Lift.

⚠ CAUTION If your Lift is not functioning correctly, you must take it out of service until it is repaired. **Qualified personnel must perform all repair work.**

⚠ WARNING The Lift uses electrical energy; if your organization has Lockout/Tagout policies, make sure to implement them before performing any Troubleshooting.

Issue	Action to Take
Once raised, Lift does not lower.	Verify there is sufficient hydraulic fluid in the reservoir. Make sure there is no air in the Hydraulic System. Make sure none of the hydraulic hoses are pinched or leaking. Make sure the power unit is getting electrical power. If the hydraulic fluid is dirty, replace it with clean fluid. Make sure the Lift is not overloaded. Make sure the load on the Lift is balanced. Contact BendPak Support at bendpak.com/support , via email at support@bendpak.com , or by phone at (800) 253-2363 select option 7, then 4.
Lift head and arms move erratically or squeak when in use.	Move the lift head up and down a few times to flush any residual air out of the Hydraulic System.
Lift does not stay up.	Make sure to leave the Lift engaged on its safety locks. Check for hydraulic fluid leaks.
Vehicle on Lift not level.	Make sure Lift is engaged on safety locks at the same height. Make sure the safety locks in both posts are engaged. If either condition is not met, carefully lower the vehicle back down to the ground and raise it again.
Motor not running.	Check connection to power source; make sure it is connected and the appropriate voltage supplied. Check wiring diagram on power unit.
Hydraulic Fluid is dirty.	Replace the dirty hydraulic fluid with clean, approved ATF fluids, such as Dexron III, Dexron VI, Mercon V, Mercon LV, or comparable.
Lift makes odd noises.	Lubricate hinge points using white lithium grease.

If you continue to have issues with your Lift, take the Lift out of service, then contact your dealer or BendPak Support at bendpak.com/support, via email at support@bendpak.com, or by phone at **(800) 253-2363** select option 7 then 4.

Broken Safety Cable Procedure

If the Safety cable breaks, the power side Lift head will lower but the off side lift head will not.

To release the Off Side Safety Lock:

1. Raise the lift heads off the safety locks.
2. Remove the off side safety cover.
3. Have an assistant attempt to retract the off side safety weldment by pulling on the safety cable near the safety sheaves on the offside post. If that method is not possible, remove one safety sheave and reach through the sheave slot with a stiff wire or pick to pull the Safety Block away from the lift head and hold it there. See the figure below.
4. Hold in the Safety Release on the power side Lift post while holding the lower handle on the power unit.
5. When the Lift heads are on the ground and the Lift is in a safe condition, remove and lock out power from the Lift and then replace the Safety cable. Refer to the Installation and Operation Manual for routing and installation instructions.

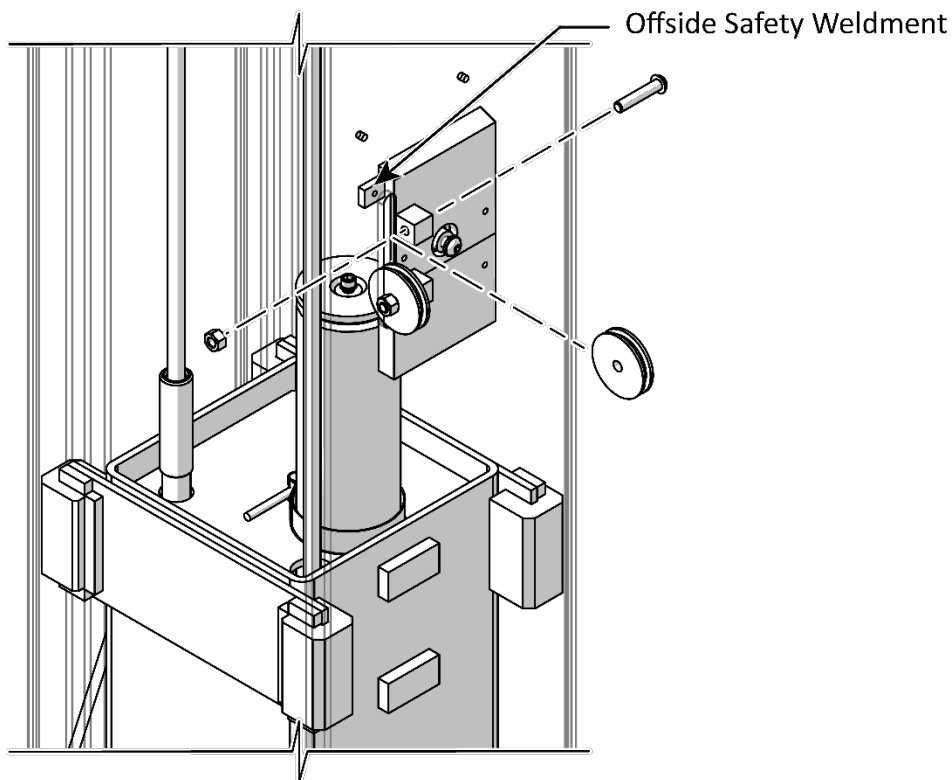

Reference only – do not scale.

Troubleshooting Lift Arm Lock Disengagement

⚠ WARNING Avoid excessive Shim heights! A new concrete cutout and steel reinforced pour are recommended to correct out of level conditions in excess of 3°.

Some floors with excessive out of level conditions may require Shim heights that reach or exceed .5 in. (12.7 mm). When the Shim Height reaches this level, the Lift Arm Lock Pins may not function to disengage the lift arms when completely lowered. To correct this condition, the Arm Lock Pins include an M12 x 1.75 internal thread, approximately 12 mm deep. A mating M12 hex head bolt with Lock washers, or a backing nut (not supplied) may be used to extend the contact point of the Arm Lock Pins. Adjust the bolt head position to disengage the Lock as required. Refer to the figure below.

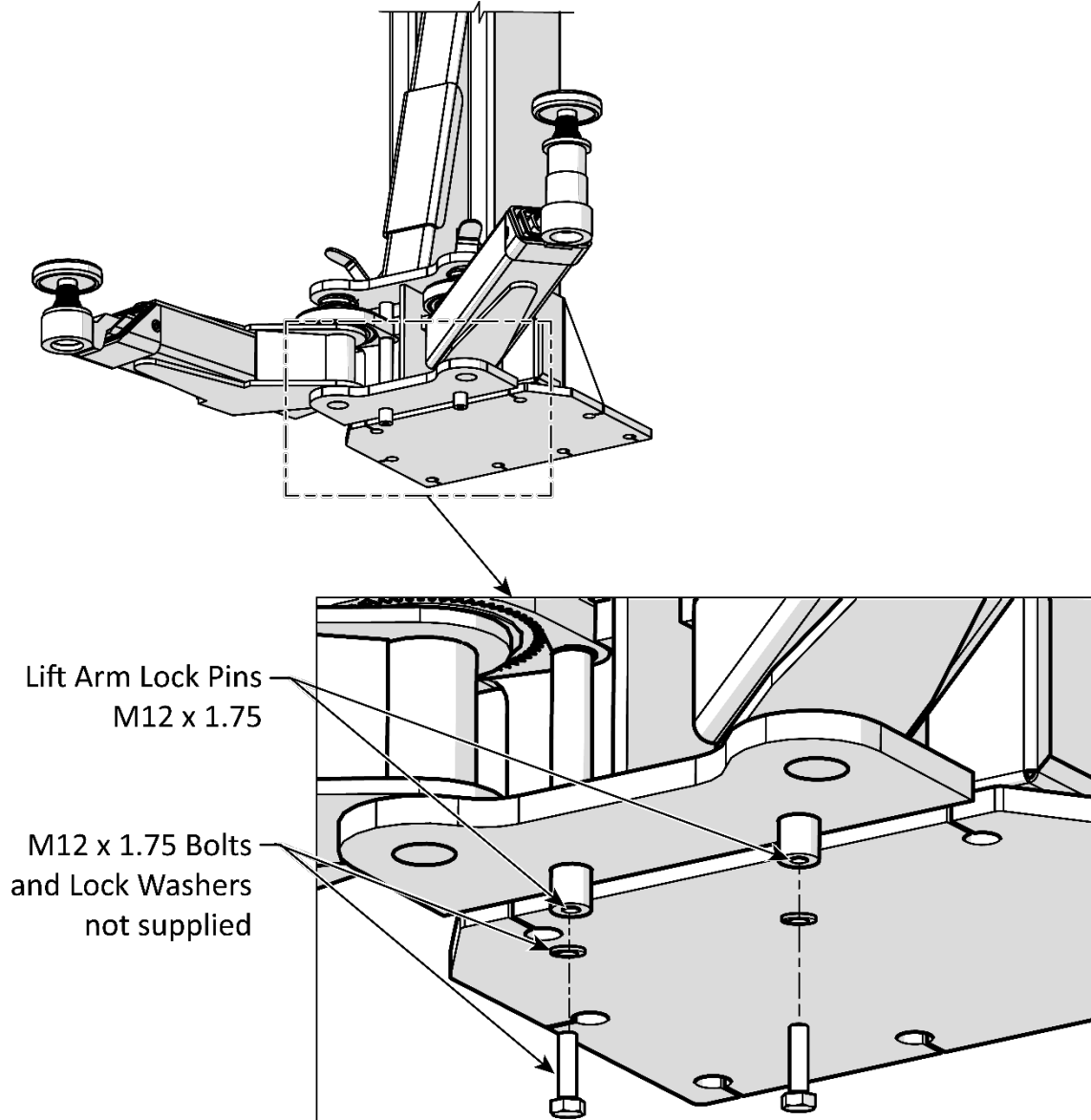

Disposing of Used Hydraulic Fluid

Used hydraulic fluid cannot be disposed of by dropping it into the trash or dumping it into the street. hydraulic fluid has toxic ingredients that are harmful to the environment. Either recycle the hydraulic fluid or drop it off at a hazardous waste collection facility. Dirty or contaminated fluid must be treated as hazardous waste. Rags and/or granular absorbents that have soaked up hydraulic fluid should be treated like hazardous waste and be disposed of at a hazardous waste collection facility.

To find an appropriate facility:

- Local automotive parts stores, auto care facilities, or automobile dealerships may accept fluid for recycling or, in some cases, for disposal. Contact them for more information.
- Cities, counties, and states often support both recycling facilities and hazardous waste collection facilities. Contact them to see if and where they have these programs.

If you are unable to find an appropriate facility, the website [earth911.com](https://www.earth911.com) has resources that may be of help.

Lift Disposal - End of Service Life

Once your Lift has reached the end of its Service Life it must be disposed of properly. Metal recyclers will be able to advise on methods and costs to remove the Lift and will reuse the materials, diverting them from landfills. The best option is to contact a metal recycling center and discuss the size and weight of the Lift to determine if the facility can deconstruct and recover the usable components and metals.

The hydraulic cylinders, Hoses, fittings, and the power unit itself must be disposed of in accordance with current national, state, and local regulations governing the use and disposal of hazardous materials. These components and any used hydraulic fluid must not be disposed of by dropping it into the trash or dumping it into the street. The hydraulic fluid contains toxic ingredients that are harmful to the environment.

These components and the hydraulic fluid are required to be recycled or must be delivered to a hazardous waste collection facility.

If you have large amounts of hydraulic fluid, consider contacting a commercial waste disposal company. In all cases, the best approach is to find an appropriate facility and contact them — in advance — to ask them: what kinds of fluids and materials they accept, what kind of containers it must be in, what hours they are open, their location, and any other information specific to their facility.

If you are unable to find an appropriate facility, the website [earth911.com](https://www.earth911.com) has resources that may be of help.

Wiring Diagram

10AP-SRT Power Units

Power Unit 5585285

208-240VAC, 1 PH, 50/60 Hz.
3 HP, 2900/3450 RPM

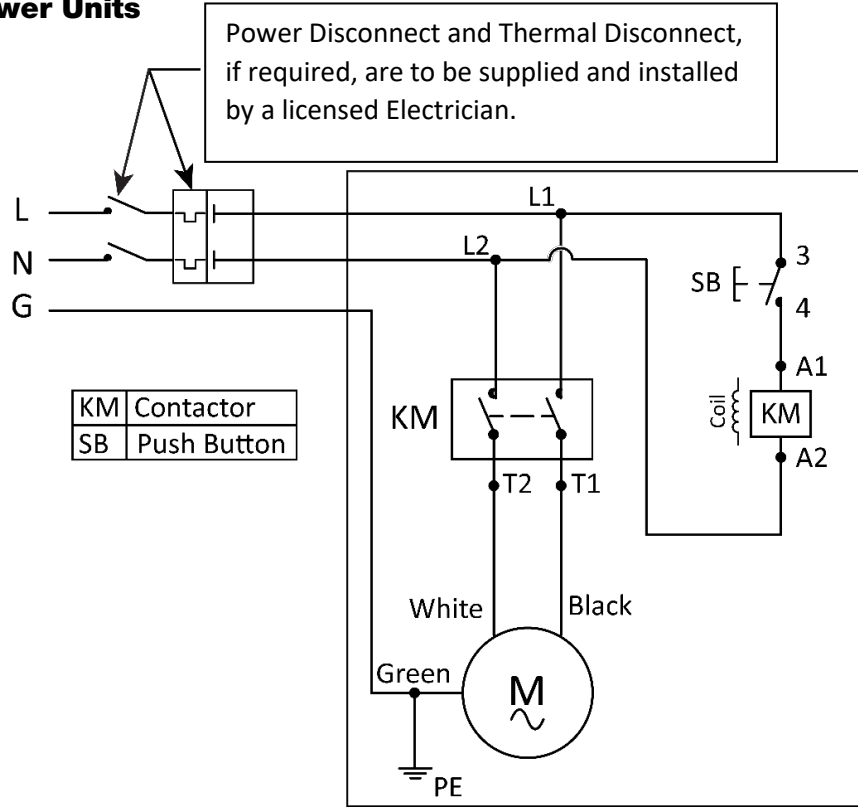

Power Unit 5585785

208-230VAC, 1 PH, 50/60 Hz.
2 HP, 2930/3520 RPM

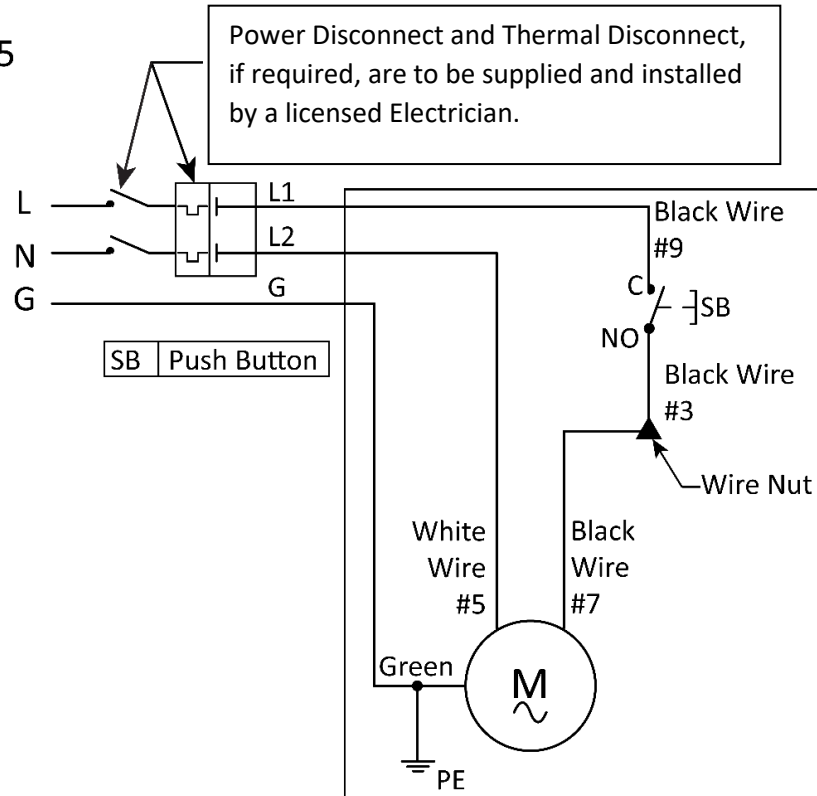

12AP-SRT Power Unit 5585685

Single-Phase

Power Disconnect and Thermal Disconnect, if required, are to be supplied and installed by a licensed Electrician.

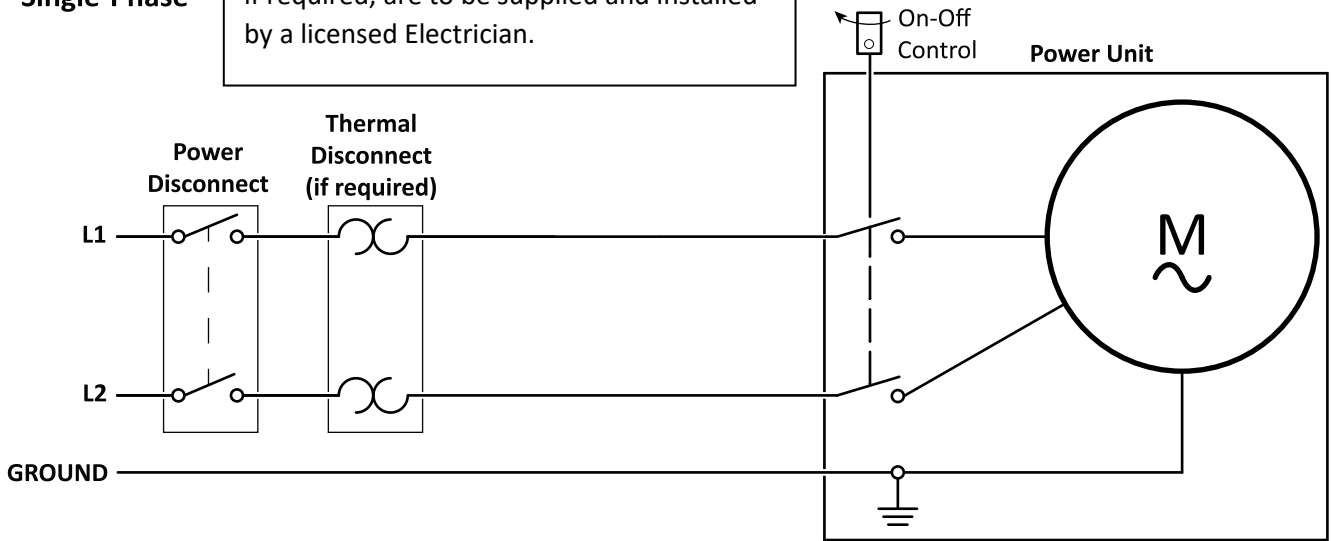

**Electric Schematic
208-230V**

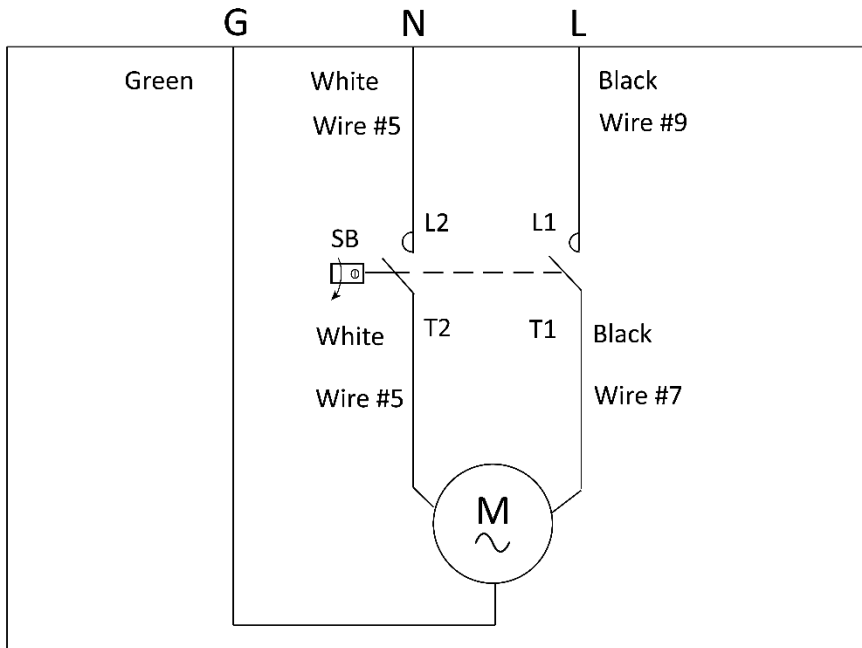

Motor
208-230V, 1PH, 50/60 HZ,
2880/3450rpm, 5HP, CSA approved

12AP-SRT Three-Phase Power Unit 5585247

Power Disconnect and Thermal Disconnect, if required, are to be supplied and installed by a licensed Electrician.

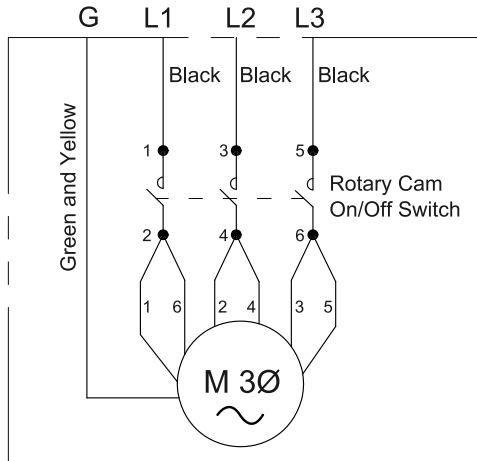

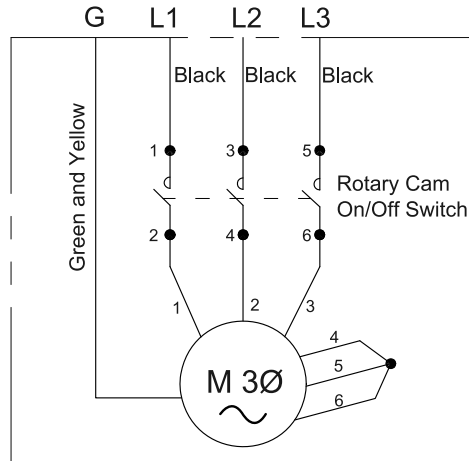

Wiring for 190/208-230V







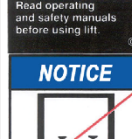

Wiring for 380/460V

G

 <p>NOTICE</p> <p>Read operating and safety manuals before using lift.</p>	 <p>NOTICE</p> <p>Proper maintenance and inspection is necessary for safe operation.</p>
 <p>NOTICE</p> <p>Do not operate a damaged lift.</p>	<p>The messages and photographs shown are generic in nature and are meant to generally represent hazards common to all automotive lifts regardless of specific style.</p> <p>Funding for the development and validation of these labels was provided by the Automotive Lift Institute, PO Box 33116 Indianapolis, IN 46203.</p> <p>They are protected by copyright. Set of labels may be obtained from ALI or its member companies.</p> <p>© 1999 by ALI, Inc. ALI/ML109</p>

**PN 5905109
(Kit includes Blue, Yellow & Orange Labels)**







 <p>CAUTION</p> <p>Lift to be used by trained operator only.</p>	 <p>CAUTION</p> <p>Authorized personnel only in lift area.</p>
 <p>CAUTION</p> <p>Use vehicle manufacturer's lift points.</p>	 <p>CAUTION</p> <p>Always use safety stands when removing or installing heavy components.</p>
 <p>CAUTION</p> <p>Use height extenders when necessary to ensure good contact.</p>	 <p>CAUTION</p> <p>Auxiliary adapters may reduce load capacity.</p>

The messages and photographs shown are generic in nature and are meant to generally represent hazards common to all automotive lifts regardless of specific style.

Funding for the development and validation of these labels was provided by the Automotive Lift Institute, PO Box 33116 Indianapolis, IN 46203.

They are protected by copyright. Set of labels may be obtained from ALI or its member companies.

© 1999 by ALI, Inc. ALI/ML109

 <p>WARNING</p> <p>Clear area if vehicle is in danger of falling.</p>	 <p>WARNING</p> <p>Position vehicle with center of gravity midway between adapters.</p>
 <p>WARNING</p> <p>Remain clear of lift when raising or lowering vehicle.</p>	 <p>WARNING</p> <p>Avoid excessive rocking of vehicle while on lift.</p>
 <p>WARNING</p> <p>Do not override self-closing lift controls.</p>	 <p>WARNING</p> <p>Keep feet clear of lift while lowering.</p>

The messages and photographs shown are generic in nature and are meant to generally represent hazards common to all automotive lifts regardless of specific style.

Funding for the development and validation of these labels was provided by the Automotive Lift Institute, PO Box 33116 Indianapolis, IN 46203.

They are protected by copyright. Set of labels may be obtained from ALI or its member companies.

© 1999 by ALI, Inc. ALI/ML109

H

PLEASE READ

Internal packing oil may cause the cylinders to bleed oil during start up. This is normal. To extend cylinder and seal life, raise the lift to full height at least once every day.

Place on BOTH Posts

PN 5905177

I

NOTICE

If attachments, accessories, or configuration modifying components used on this lift are located in the load path and affect operation of the lift, affect the lift electrical listing, or affect intended vehicle accommodation; and if they are not certified for use on this lift, then the certification of this lift shall become null and void. Contact the participant for information pertaining to certified attachments, accessories, or configuration modifying components.

www.autolift.org ©2011 by ALI, Inc. ALI / WLSIA01

PN 5905377

J

K

TO RAISE LIFT:

1. Press and hold **UP** button.
2. When lift is just **PAST** desired height, release **UP** button.
3. Hold down Lowering Handle. **DO NOT** hold down Safety Lock Release Handle. Lift engages on safety locks.
4. Release Lowering Handle.

TO LOWER LIFT:

1. Press and hold **UP** button for two to three seconds, moving lift off safety locks.
2. Hold down Safety Lock Release Handle **and** Lowering Handle.
3. When lift is fully lowered, release both handles.

PN 5905414

PN 5905414

L

CALIFORNIA PROPOSITION 65
⚠ WARNING ⚠
WARNING! This product can expose you to chemicals including styrene and vinyl chloride which are on the list of over 900 chemicals identified by the State of California to cause cancer, birth defects or reproductive harm. **ALWAYS** use this product in accordance with the manufacturer's instructions. For more information, go to www.p65warnings.ca.gov. PN 5905775

M



PN 5906044

PN 5905775

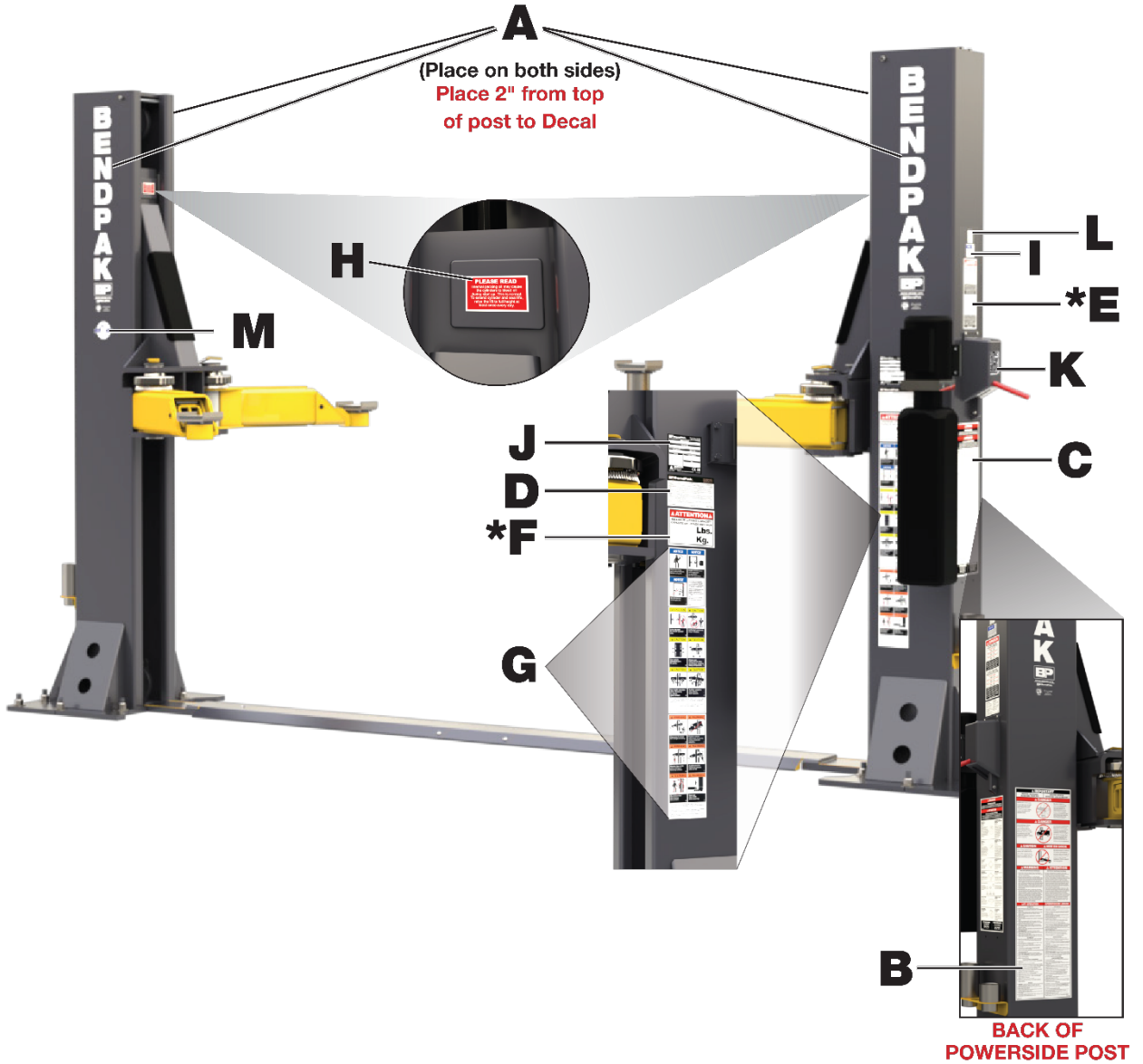

Parts Drawings

10AP-SRT

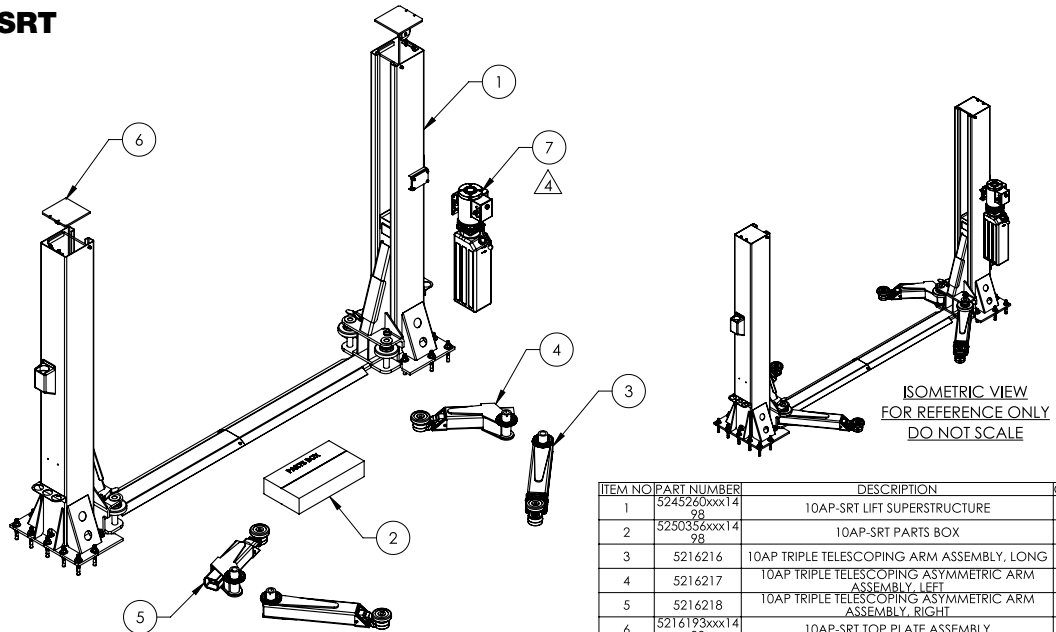

ITEM NO	PART NUMBER	DESCRIPTION	QTY	REV
1	5243260xxx14 98	10AP-SRT LIFT SUPERSTRUCTURE	1	E
2	5250356xxx14 98	10AP-SRT PARTS BOX	1	F
3	5216216	10AP TRIPLE TELESCOPING ARM ASSEMBLY, LONG	2	D
4	5216217	10AP TRIPLE TELESCOPING ASYMMETRIC ARM ASSEMBLY, LEFT	1	D
5	5216218	10AP TRIPLE TELESCOPING ASYMMETRIC ARM ASSEMBLY, RIGHT	1	D
6	5216193xxx14 98	10AP-SRT TOP PLATE ASSEMBLY	2	D
7	REF	POWER UNIT	1	-

DO NOT SCALE DRAWING

NAME: **BP BendPak** DATE: 02/27/2023
 1645 LEMONWOOD DR.
 SANTA PAULA, CA 93060

DRAWN: RK CHECKED: RK

THIRD ANGLE PROJECTION

TITLE: 10AP-SRT PRODUCTION LIFT VER A

SIZE: DWG. NO. **A** 5260693xxx1498 REV: F

SCALE: 1:30 SHEET 1 OF 3

- NOTE: UNLESS OTHERWISE SPECIFIED**
- REFER TO MODEL FOR ADDITIONAL INFORMATION
 - SEE COLORS & GRAPHICS FOR LABEL PLACEMENT
 - SEE SHIPPING INSTRUCTIONS FOR FINAL PACKAGING
- 4.** POWER UNIT REFERENCE ON PURCHASE ORDER

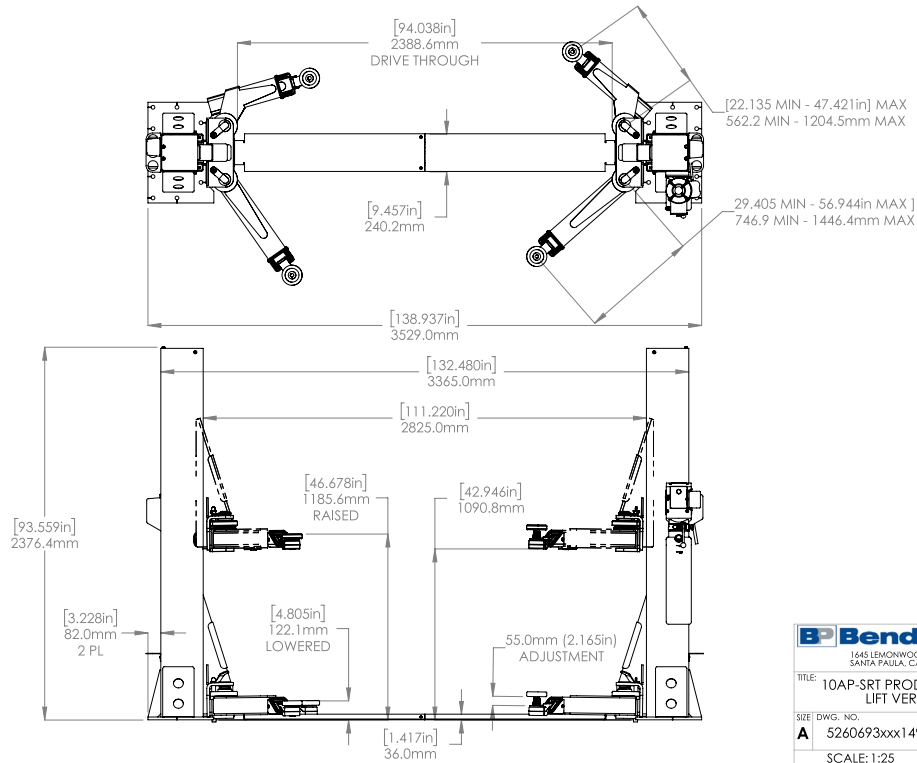

BP BendPak
 1645 LEMONWOOD DR.
 SANTA PAULA, CA 93060

TITLE: 10AP-SRT PRODUCTION LIFT VER A

SIZE: DWG. NO. **A** 5260693xxx1498 REV: F

SCALE: 1:25 SHEET 2 OF 3

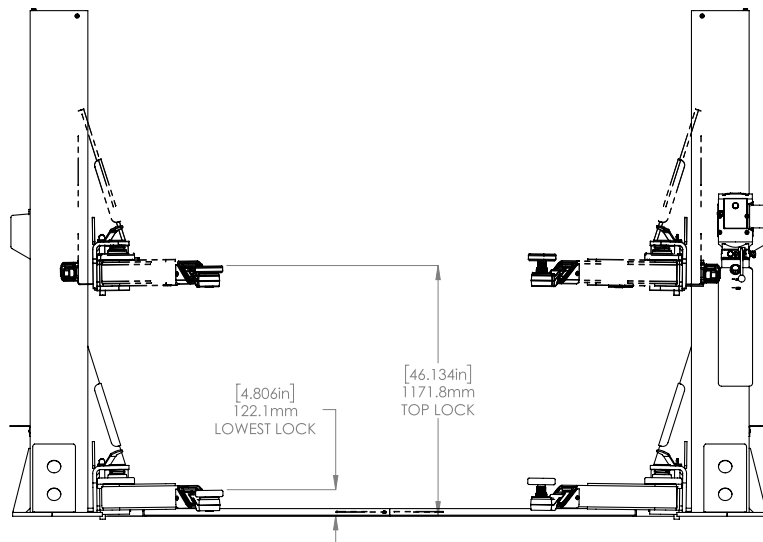

- 1. SAFETY LOCK POSITIONS: 8
- 2. SPACED EVERY: 95.0mm / 3.740"

BendPak.
 1645 LEMONWOOD DR.
 SANTA PAULA, CA 93060

TITLE: 10AP-SRT PRODUCTION LIFT VER A

SIZE	DWG. NO.	REV
A	5260693xxx1498	F

SCALE: 1:20 SHEET 3 OF 3

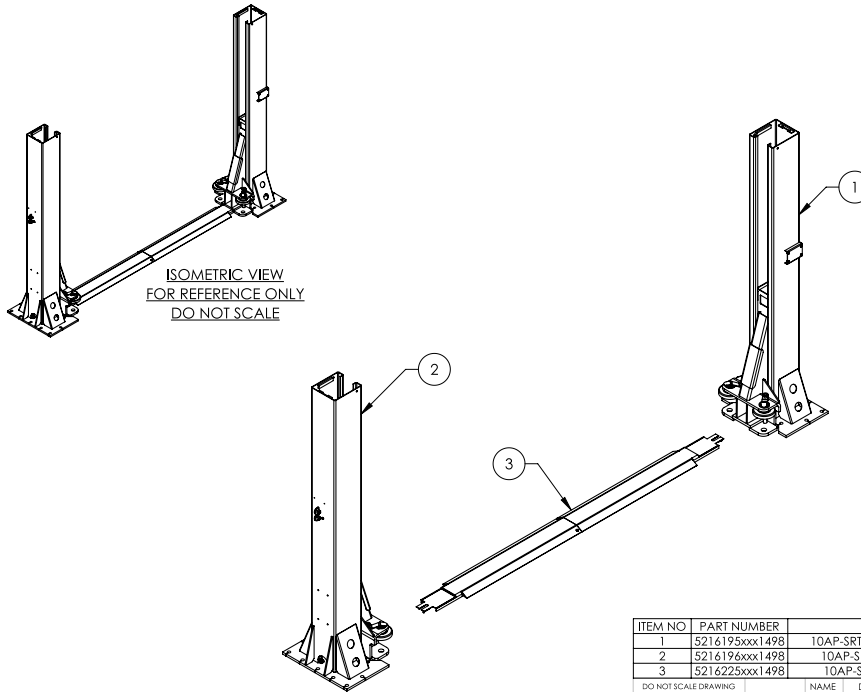

WHERE USED
10AP-SRT

- NOTE: UNLESS OTHERWISE SPECIFIED**
- 1. REFER TO MODEL FOR ADDITIONAL INFORMATION
 - 2. SEE SHIPPING INSTRUCTIONS FOR FINAL PACKAGING
 - 3. ASSEMBLE ITEMS AS SHOWN

NEXT ASSEMBLY
5260693xxx1498

ITEM NO	PART NUMBER	DESCRIPTION	QTY	REV
1	5216195xxx1498	10AP-SRT POWER SIDE POST ASSEMBLY	1	E
2	5216196xxx1498	10AP-SRT OFF SIDE POST ASSEMBLY	1	E
3	5216225xxx1498	10AP-SRT FLOOR PLATE ASSEMBLY	1	B

DO NOT SCALE DRAWING	NAME	DATE	BendPak. 1645 LEMONWOOD DR. SANTA PAULA, CA 93060
	RK	02/27/2023	
DIMENSIONS ARE IN MM	THIRD ANGLE PROJECTION		TITLE: 10AP-SRT LIFT SUPERSTRUCTURE
	PROPRIETARY AND CONFIDENTIAL	SIZE	REV
	THE INFORMATION CONTAINED IN THIS DRAWING IS THE SOLE PROPERTY OF BENDPAK INC. (B) ALL RIGHTS RESERVED. FOR REUSE OR REPRODUCTION WITHOUT THE WRITTEN PERMISSION OF BENDPAK INC. IS PROHIBITED.	A	5245260xxx1498
		SCALE: 1:30	SHEET 1 OF 1

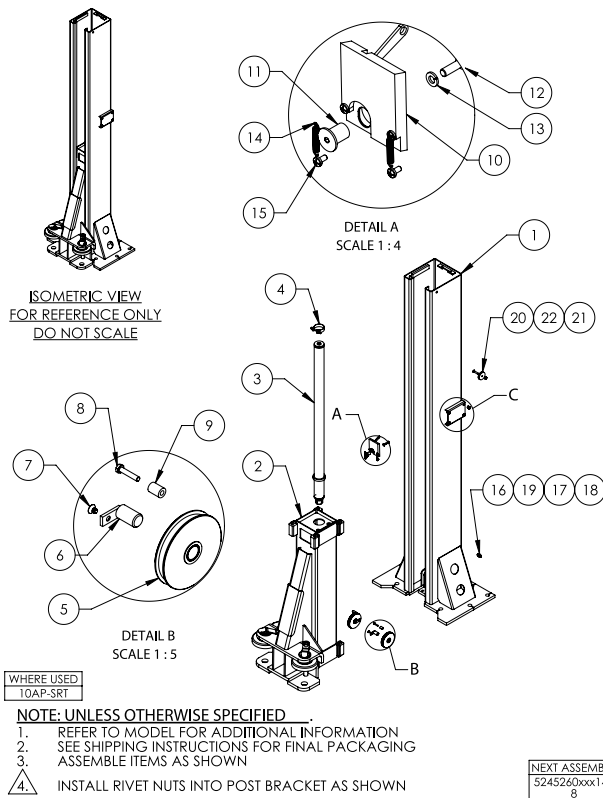

ITEM NO	PART NUMBER	DESCRIPTION	QTY	REV
1	5601893xxx1498	10AP-SRT POWER SIDE POST WELDMENT	1	E
2	5216194xxx1498	10AP-SRT LIFT HEAD ASSEMBLY	1	E
3	5502056xxx1498	CYLINDER ASSEMBLY Ø2.0 x 42"	1	C
4	5701242	CYLINDER CLAMP ASSY	1	A
5	5575068	10AP 100mm SHEAVE ASSEMBLY	2	B
6	5620143	D2-10, 10AP CABLE SHEAVE PIN WELDMENT	2	C
7	5530366	FHSS M6 x 1.0 x 8	2	A
8	5530047	HHB, M6 x 1 x 30mmL	2	A
9	5746711xxx1498	10AP-SRT SHEAVE PLATE SPACER	2	A
10	5601516xxx1498	10AP-SRT POWER SIDE SAFETY WELDMENT	1	A
11	5744494	10/12/16/20AP SAFETY PIVOT PIN	1	C
12	5530414	BHSS M8 x 1.25 x 25 CL10.9	1	A
13	5545202	WASHER M8 x Ø15 SL, CL10.9	1	A
14	5540047	EXTENSION SPRING Ø6.35 x 38mm	2	C
15	5530045	BHPS M5 x 0.8 x 10 FT. CL. 8.8	4	B
16	5575074	10/12/16/20AP SAFETY CABLE ROLLER	1	A
17	5565350	AP/GP/PCL/XPR/ PL-7000 SAFETY SHEAVE SPACER	1	C
18	5530756	HHB M6 x 1.0 x 25 FT. CL 10.9	1	B
19	5535357	NUT M6 x 1.0 NL, CL10.9	1	-
20	5575325	Ø50mm SAFETY SHEAVE	1	A
21	5530407	BHSS M8 x 1.25 x 40 FT. CL10.9	1	-
22	5535001	NUT M8 x 1.25 NL, CL10.9	1	-
23	5535057	NUT M8 x 1.25 x 17.5, RIVET	4	--

DO NOT SCALE DRAWING

NAME: **BP BendPak**
 DRAWN: RK
 CHECKED: 02/27/2023
 1645 LEMMONWOOD DR.
 SANTA PAULA, CA 93060

THIRD ANGLE PROJECTION

TITLE: 10AP-SRT POWER SIDE POST ASSEMBLY

SIZE: DWG. NO. **A** 5216195xxx1498 REV **E**

SCALE: 1:25 SHEET 1 OF 1

PROPRIETARY AND CONFIDENTIAL
 THE INFORMATION CONTAINED HEREIN IS THE PROPERTY OF BENDPAK INC. ANY REPRODUCTION OR DISSEMINATION WITHOUT THE WRITTEN PERMISSION OF BENDPAK INC. IS PROHIBITED.

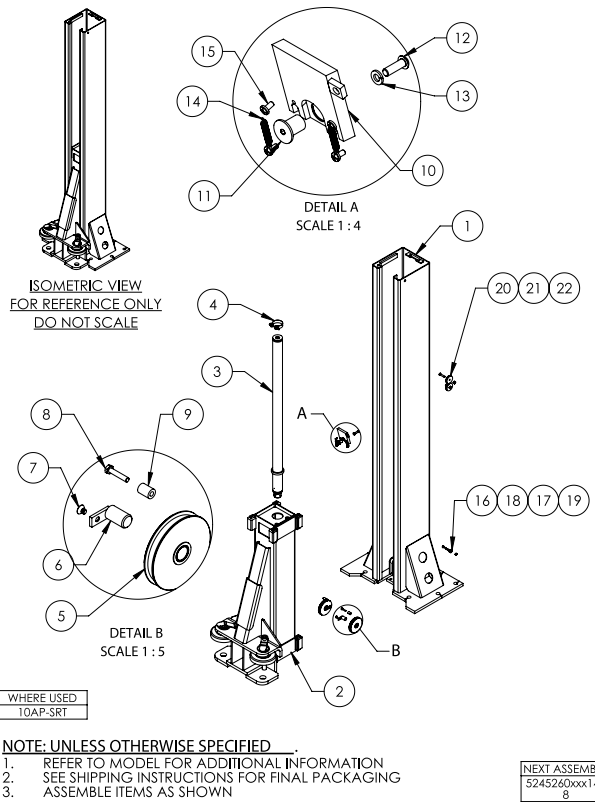

ITEM NO	PART NUMBER	DESCRIPTION	QTY	REV
1	5601894xxx1498	10AP-SRT OFF SIDE POST WELDMENT	1	D
2	5216194xxx1498	10AP-SRT LIFT HEAD ASSEMBLY	1	E
3	5502056xxx1498	CYLINDER ASSEMBLY Ø2.0 x 42"	1	C
4	5701242	CYLINDER CLAMP ASSY	1	-
5	5575068	10AP 100mm SHEAVE ASSEMBLY	2	B
6	5620143	D2-10, 10AP CABLE SHEAVE PIN WELDMENT	2	C
7	5530366	FHSS M6 x 1.0 x 8	2	-
8	5530047	HHB, M6 x 1 x 30mmL	2	-
9	5746711xxx1498	10AP-SRT SHEAVE PLATE SPACER	2	A
10	5601952xxx1498	10AP-SRT OFF SIDE SAFETY BLOCK WELDMENT	1	A
11	5744494	10/12/16/20AP SAFETY PIVOT PIN	1	C
12	5530414	BHSS M8 x 1.25 x 25 CL10.9	1	-
13	5545202	WASHER M8 x Ø15 SL, CL10.9	1	-
14	5540047	EXTENSION SPRING Ø6.35 x 38mm	2	-
15	5530045	BHPS M5 x 0.8 x 10 FT. CL. 8.8	4	-
16	5575074	10/12/16/20AP SAFETY CABLE ROLLER	1	A
17	5565350	AP/GP/PCL/XPR/ PL-7000 SAFETY SHEAVE SPACER	1	C
18	5530756	HHB M6 x 1.0 x 25 FT. CL 10.9	1	-
19	5535357	NUT M6 x 1.0 NL, CL10.9	1	-
20	5575325	Ø50mm SAFETY SHEAVE	2	A
21	5530407	BHSS M8 x 1.25 x 40 FT. CL10.9	2	-
22	5535001	NUT M8 x 1.25 NL, CL10.9	2	-

DO NOT SCALE DRAWING

NAME: **BP BendPak**
 DRAWN: RK
 CHECKED: 02/27/2023
 1645 LEMMONWOOD DR.
 SANTA PAULA, CA 93060

THIRD ANGLE PROJECTION

TITLE: 10AP-SRT OFF SIDE POST ASSEMBLY

SIZE: DWG. NO. **A** 5216196xxx1498 REV **E**

SCALE: 1:25 SHEET 1 OF 1

PROPRIETARY AND CONFIDENTIAL
 THE INFORMATION CONTAINED HEREIN IS THE PROPERTY OF BENDPAK INC. ANY REPRODUCTION OR DISSEMINATION WITHOUT THE WRITTEN PERMISSION OF BENDPAK INC. IS PROHIBITED.

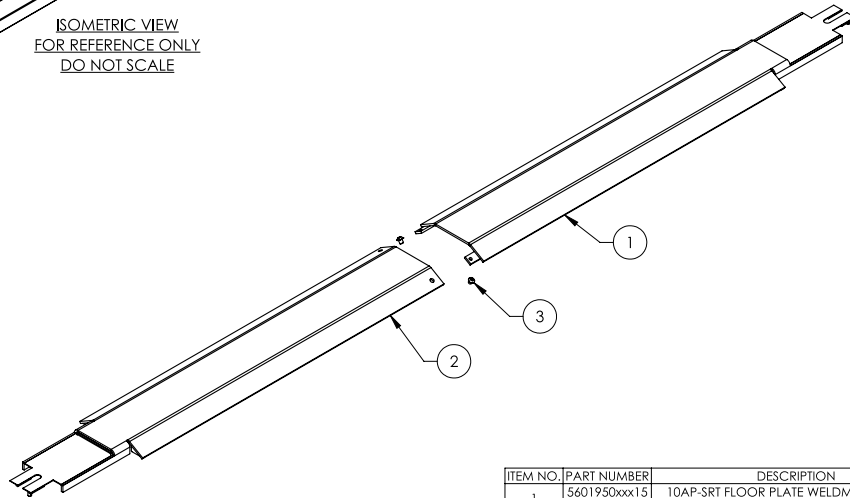
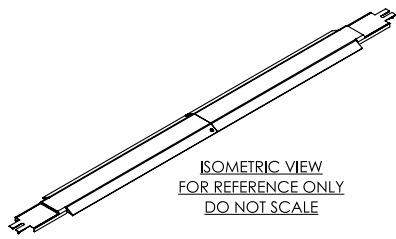

WHERE USED
10AP-SRT

NOTE: UNLESS OTHERWISE SPECIFIED...
 1. REFER TO MODEL FOR ADDITIONAL INFORMATION
 2. SEE SHIPPING INSTRUCTIONS FOR FINAL PACKAGING

NEXT ASSEMBLY
5245260xxx1498

ITEM NO.	PART NUMBER	DESCRIPTION	QTY.	REV
1	5601950xxx1536	10AP-SRT FLOOR PLATE WELDMENT, POWER SIDE	1	A
2	5601951xxx1536	10AP-SRT FLOOR PLATE WELDMENT, OFF SIDE	1	A
3	5530480	BHSS M10 x 1.5 x 12 FT. CL 10.9	2	-

DO NOT SCALE DRAWING		NAME	DATE	BendPak 1445 LEMONWOOD DR. SANTA PAULA, CA 93060
DRAWN	RK	06/02/2023		
DIMENSIONS ARE IN MM		CHECKED		TITLE: 10AP-SRT FLOOR PLATE ASSEMBLY
THIRD ANGLE PROJECTION				SIZE: DWG. NO. REV
		<small>PROPRIETARY AND CONFIDENTIAL THE INFORMATION CONTAINED IN THIS DRAWING IS THE SOLE PROPERTY OF BENDPAK INC. ALL RIGHTS ARE RESERVED. NO PART OF THIS DRAWING MAY BE REPRODUCED OR TRANSMITTED IN ANY FORM OR BY ANY MEANS, WITHOUT THE WRITTEN PERMISSION OF BENDPAK INC. ©</small>		A 5216225xxx1498 B
				SCALE: 1:12 SHEET 1 OF 1

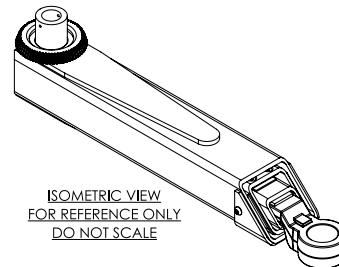
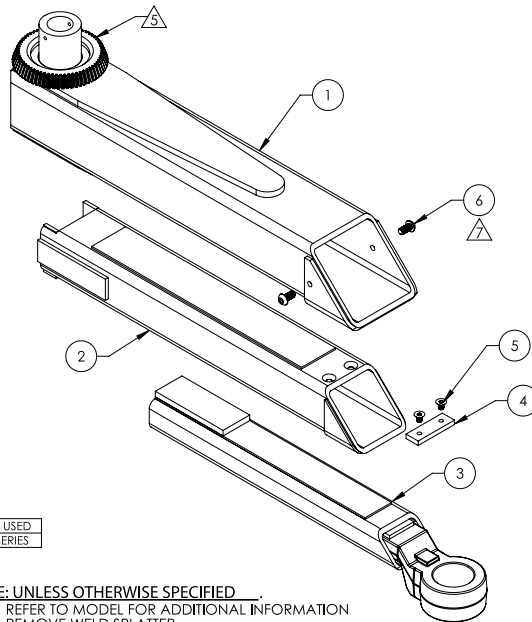

WHERE USED
10AP SERIES

NOTE: UNLESS OTHERWISE SPECIFIED...
 1. REFER TO MODEL FOR ADDITIONAL INFORMATION
 2. REMOVE WELD SPLATTER
 3. SEE SHIPPING INSTRUCTIONS FOR FINAL PACKAGING
 4. ASSEMBLE ITEMS AS SHOWN
 5. **MASK TEETH BEFORE PAINTING**
 6. MASK BORE AND ALL THREADS BEFORE PAINTING
 7. APPLY LOCTITE BLUE 242 AND CURE PER MANUFACTURE SPECIFICATION
 8. DIMENSIONS SHOWN ARE AFTER WELDING AND PAINTING
 9. PAINT YELLOW (RAL-1018) 20% GLOSS

NEXT ASSEMBLY
5240699
5240700
5240701

ITEM NO.	PART NUMBER	DESCRIPTION	QTY.	REV
1	5601937	10AP LONG ARM WELDMENT, OUTER SECTION	1	D
2	5601936	10AP LONG ARM WELDMENT, MIDDLE SECTION	1	B
3	5601512	10AP LONG ARM WELDMENT, INNER SECTION	1	H
4	5737188	10/12AP MIDDLE ARM SECTION SLIDE STOP	1	B
5	5530382	FHSS M8 x 1.25 x 12 CL10.9	2	-
6	5530479	BHSS M10 x 1.5 x 20 FT. CL 10.9 B.O.	2	-

DO NOT SCALE DRAWING		NAME	DATE	BendPak 1445 LEMONWOOD DR. SANTA PAULA, CA 93060
DRAWN	TJA	04/20/2023		
DIMENSIONS ARE IN MM		CHECKED		TITLE: 10AP TRIPLE TELESCOPING ARM ASSEMBLY, LONG
THIRD ANGLE PROJECTION				SIZE: DWG. NO. REV
		<small>PROPRIETARY AND CONFIDENTIAL THE INFORMATION CONTAINED IN THIS DRAWING IS THE SOLE PROPERTY OF BENDPAK INC. ALL RIGHTS ARE RESERVED. NO PART OF THIS DRAWING MAY BE REPRODUCED OR TRANSMITTED IN ANY FORM OR BY ANY MEANS, WITHOUT THE WRITTEN PERMISSION OF BENDPAK INC. ©</small>		A 5216216 D
				SCALE: 1:6 SHEET 1 OF 2

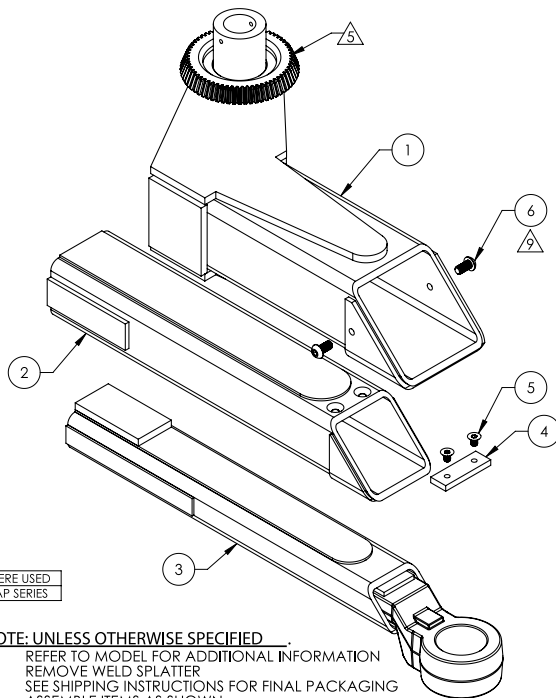

WHERE USED
10AP SERIES

NOTE: UNLESS OTHERWISE SPECIFIED

1. REFER TO MODEL FOR ADDITIONAL INFORMATION
2. REMOVE WELD SPLATTER
3. SEE SHIPPING INSTRUCTIONS FOR FINAL PACKAGING
4. ASSEMBLE ITEMS AS SHOWN
5. **MASK TEETH BEFORE PAINTING**
6. MASK BORE AND ALL THREADS BEFORE PAINTING
7. DIMENSIONS SHOWN ARE AFTER WELDING AND PAINTING
8. PAINT YELLOW (RAL-1018) 20% GLOSS
9. APPLY LOCTITE BLUE 242 AND CURE PER MANUFACTURE SPECIFICATION

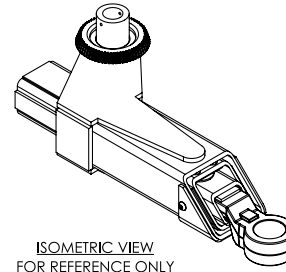

ITEM NO	PART NUMBER	DESCRIPTION	QTY	REV
1	5601938	10AP ASYMMETRIC ARM WELDMENT, OUTER SECTION, LEFT	1	C
2	5601753	10AP ASYMMETRIC ARM WELDMENT, MIDDLE SECTION	1	B
3	5601752	10AP ASYMMETRIC ARM WELDMENT, INNER SECTION	1	D
4	5737188	10/12AP MIDDLE ARM SECTION SLIDE STOP	1	B
5	5530382	FHSS M8 x 1.25 x 12 CL10.9	2	-
6	5530479	BHSS M10 x 1.5 x 20 FT. CL 10.9 B.O.	2	-

DO NOT SCALE DRAWING		NAME	DATE	 1645 LEMONWOOD DR. SANTA PAULA, CA 93060
DRAWN	TM	04/21/2023		
CHECKED				TITLE: 10AP TRIPLE TELESCOPING ASYMMETRIC ARM ASSEMBLY, LEFT SIZE DWG. NO. A 5216217 REV D
THIRD ANGLE PROJECTION				
DIMENSIONS ARE IN MM				SCALE: 1:5 SHEET 1 OF 2

NEXT ASSEMBLY
5260698
5260699
5260700
5260701

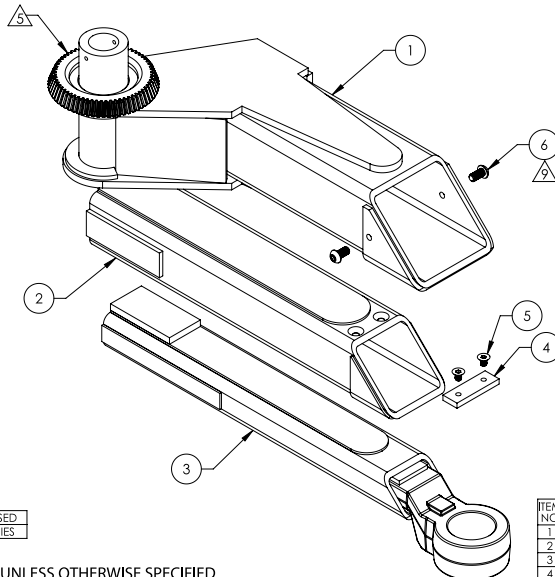

WHERE USED
10AP SERIES

NOTE: UNLESS OTHERWISE SPECIFIED

1. REFER TO MODEL FOR ADDITIONAL INFORMATION
2. REMOVE WELD SPLATTER
3. SEE SHIPPING INSTRUCTIONS FOR FINAL PACKAGING
4. ASSEMBLE ITEMS AS SHOWN
5. **MASK TEETH BEFORE PAINTING**
6. MASK BORE AND ALL THREADS BEFORE PAINTING
7. DIMENSIONS SHOWN ARE AFTER WELDING AND PAINTING
8. PAINT YELLOW (RAL-1018) 20% GLOSS
9. APPLY LOCTITE BLUE 242 AND CURE PER MANUFACTURE SPECIFICATION

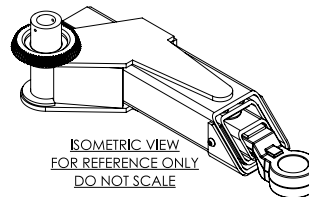

ITEM NO	PART NUMBER	DESCRIPTION	QTY	REV
1	5601939	10AP ASYMMETRIC ARM WELDMENT, OUTER SECTION, RIGHT	1	C
2	5601753	10AP ASYMMETRIC ARM WELDMENT, MIDDLE SECTION	1	B
3	5601752	10AP ASYMMETRIC ARM WELDMENT, INNER SECTION	1	D
4	5737188	10/12AP MIDDLE ARM SECTION SLIDE STOP	1	B
5	5530382	FHSS M8 x 1.25 x 12 CL10.9	2	-
6	5530479	BHSS M10 x 1.5 x 20 FT. CL 10.9 B.O.	2	-

DO NOT SCALE DRAWING		NAME	DATE	 1645 LEMONWOOD DR. SANTA PAULA, CA 93060
DRAWN	TM	04/24/2023		
CHECKED				TITLE: 10AP TRIPLE TELESCOPING ASYMMETRIC ARM ASSEMBLY, RIGHT SIZE DWG. NO. A 5216218 REV D
THIRD ANGLE PROJECTION				
DIMENSIONS ARE IN MM				SCALE: 1:5 SHEET 1 OF 2

NEXT ASSEMBLY
5260698
5260699
5260700
5260701

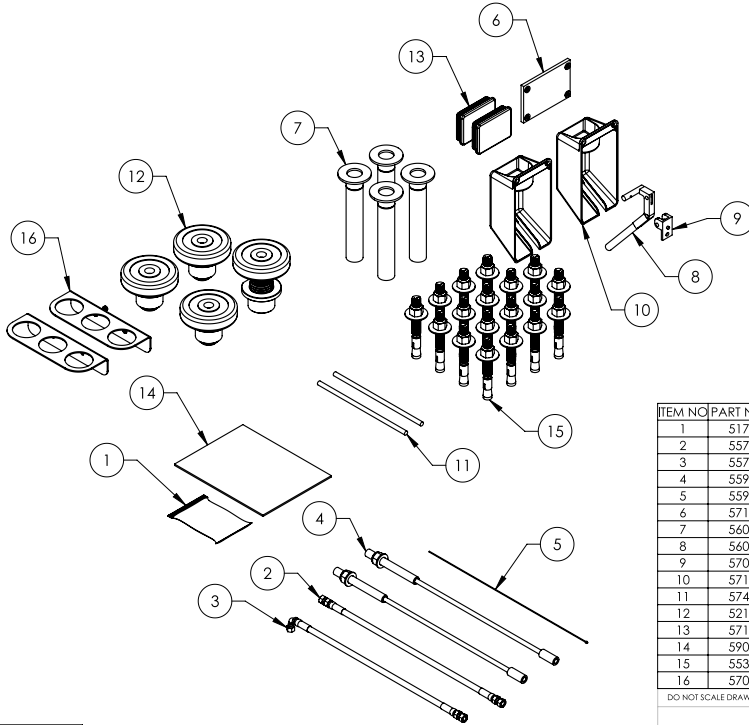

WHERE USED
10AP-SRT

- NOTE: UNLESS OTHERWISE SPECIFIED:**
1. REFER TO MODEL FOR ADDITIONAL INFORMATION
 2. INSERT PARTS BAG INTO PARTS BOX FOR SHIPMENT
 3. HOSES AND CABLES SHOWN REPRESENTATIONAL FORM

NEXT ASSEMBLY
5260693xxx149
8

ITEM NO	PART NUMBER	DESCRIPTION	QTY	REV
1	5174125	10/12AP-SRT PARTS BAG	1	E
2	5570063	HYDRAULIC HOSE ASSEMBY Ø6.35 x 3048mm DS	1	B
3	5570750	HYDRAULIC HOSE ASSEMBY Ø6.4 x 1212mm SB	1	C
4	5595911	CABLE ASSEMBLY Ø10 x 7270mm ST	2	J
5	5595793	SAFETY CABLE Ø1.8 x 7773mm	1	A
6	5715003	POWER UNIT VIBRATION DAMPENER	1	B
7	5601505	10AP ARM LOCK PIN WELDMENT, Ø38	4	C
8	5601892	12AP-SRT SAFETY HANDLE WELDMENT	1	B
9	5700404	AP SAFETY PIVOT HOLDER	1	C
10	5716094	12AP-SRT PLASTIC SAFETY COVER	2	C
11	5746167	DOUBLE THREADED ROD M10 x 1.5 x 275	2	B
12	5216239	ROUND ADJUSTABLE LIFT PAD ASSEMBLY	4	A
13	5715196	POLYETHYLENE COVER BLOCK 105 x 80	2	D
14	5900354	SRT INSTALLATION MANUAL	1	-
15	5530337	AB 3/4" x 6.3"	18	-
16	5701660	HEIGHT ADAPTER HOLDER, 60mm PIN	2	B

DO NOT SCALE DRAWING

NAME: CA DATE: 06/27/2023

DRAWN: CA CHECKED: CA

1645 LEMONWOOD DR, SANTA PAULA, CA 93060

THIRD ANGLE PROJECTION

TITLE: 10AP-SRT PARTS BOX

SIZE: DWG. NO. A 5250356xxx1498 REV F

SCALE: 1:10 SHEET 1 OF 1

PROPRIETARY AND CONFIDENTIAL
THE INFORMATION CONTAINED HEREIN IS THE SOLE PROPERTY OF BENDPAK INC. ANY REPRODUCTION IN WHOLE OR IN PART WITHOUT THE WRITTEN PERMISSION OF BENDPAK INC. IS PROHIBITED.

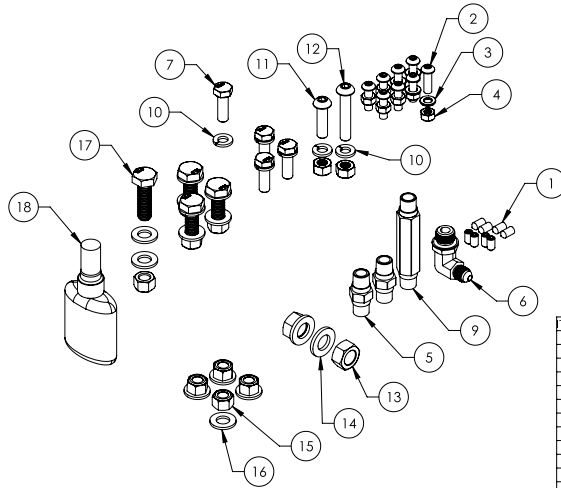

WHERE USED
10AP-SRT
12AP-SRT

- NOTE: UNLESS OTHERWISE SPECIFIED:**
1. SEE SHIPPING INSTRUCTIONS FOR FINAL PACKAGING

NEXT ASSEMBLY
5250356
5250356xxx149
8

ITEM NO	PART NUMBER	DESCRIPTION	QTY	REV
1	5530423	SSS M6 x 1.0 x 12 CONE, CL 10.9	8	-
2	5530065	BHSC M6 x 1.0 x 20 FT, CL 10.9	8	-
3	5545005	WASHER M6 x 12 FLAT, CL 10.9	4	-
4	5535357	NUT M6 x 1.0 NL, CL10.9	8	-
5	5550147	FTG NPL -04 JIC x -04 NPT	2	-
6	5550103	FTG ELB -04 JIC -06 ORB	1	-
7	5530010	HHB M8 x 1.25 x 25 FT, CL 10.9	4	-
8	5535001	NUT M8 x 1.25 NL, CL10.9	2	-
9	5550228	FTG NPL -04 NPTF x -04 JIC, 3.25 LONG	1	-
10	5545202	WASHER M8 x Ø15 SL, CL10.9	6	-
11	5530412	BHSC M8 x 1.25 x 30 CL10.9	1	-
12	5530413	BHSC M8 x 1.25 x 45 CL10.9	1	-
13	5535354	NUT M12 x 1.75, CL 10.9	2	-
14	5545347	WASHER M12 x 24 FLAT, CL 10.9	2	-
15	5535013	NUT M10 x 1.5 NL, CL10.9	8	-
16	5545341	WASHER M10 x Ø20 FLAT, CL10.9	12	-
17	5530106	HHB M10 x 1.5 x 35 FT, CL 10.9	4	-
18	5580012	LIQUID PTFE THREAD SEALANT 50ml	1	-

DO NOT SCALE DRAWING

NAME: OR DATE: 12/29/2022

DRAWN: OR CHECKED: OR

1645 LEMONWOOD DR, SANTA PAULA, CA 93060

THIRD ANGLE PROJECTION

TITLE: 10/12AP-SRT PARTS BAG

SIZE: DWG. NO. A 5174125 REV E

SCALE: 1:3 SHEET 1 OF 1

PROPRIETARY AND CONFIDENTIAL
THE INFORMATION CONTAINED HEREIN IS THE SOLE PROPERTY OF BENDPAK INC. ANY REPRODUCTION IN WHOLE OR IN PART WITHOUT THE WRITTEN PERMISSION OF BENDPAK INC. IS PROHIBITED.

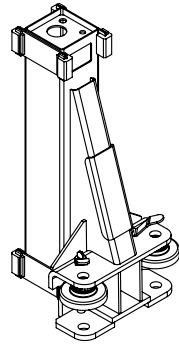

ISOMETRIC VIEW
FOR REFERENCE ONLY
DO NOT SCALE

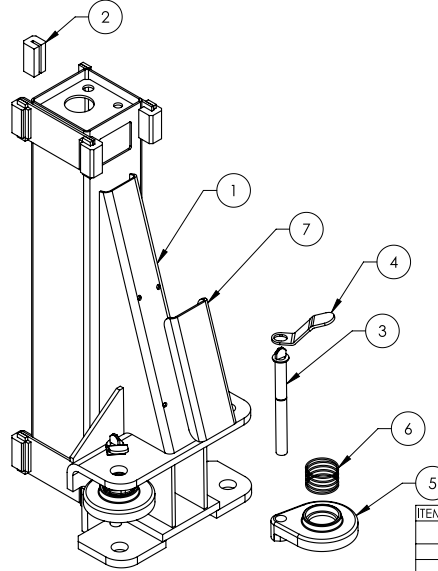

WHERE USED
10AP-SRT

NOTE: UNLESS OTHERWISE SPECIFIED

1. REFER TO MODEL FOR ADDITIONAL INFORMATION
2. SEE SHIPPING INSTRUCTIONS FOR FINAL PACKAGING
3. ASSEMBLE ITEMS AS SHOWN

ITEM NO	PART NUMBER	DESCRIPTION	QTY	REV
1	5601895xxx1498	10AP-SRT LIFT HEAD WELDMENT	1	D
2	5716001	2 POST GUIDE BLOCK	8	H
3	5602029	10AP ARM LOCK GUIDE ROD WELDMENT, GROOVE	2	A
4	5701700	AP ARM LOCK RELEASE HANDLE	2	C
5	5701954	10/12AP ARM INTERNAL FULL CIRCLE GEAR STOP, THREADED HOLES	2	A
6	5540044	COMPRESSION SPRING Ø74 x 40mm	2	-
7	5930003	10AP_D2-10_XPR-9TF LIFT HEAD GUSSET COVER	1	B

DO NOT SCALE DRAWING

NAME: **BP BendPak** DATE: 02/27/2023
 1645 LEMONWOOD DR.
 SANTA PAULA, CA 93060

DRAWN: RK
 CHECKED: [Signature]

THIRD ANGLE PROJECTION

TITLE: 10AP-SRT LIFT HEAD ASSEMBLY

SIZE: DWG. NO. **A** 5216194xxx1498 REV **E**

SCALE: 1:10 SHEET 1 OF 2

PROPRIETARY AND CONFIDENTIAL
 THE INFORMATION CONTAINED IN THIS DRAWING IS THE SOLE PROPERTY OF BENDPAK INC. AND IS TO BE USED FOR THE MANUFACTURE OF BENDPAK EQUIPMENT WITHOUT THE WRITTEN PERMISSION OF BENDPAK INC. IT IS FORWARDED.

NEXT ASSEMBLY

5216195xxx1498
8
5216196xxx1498
8

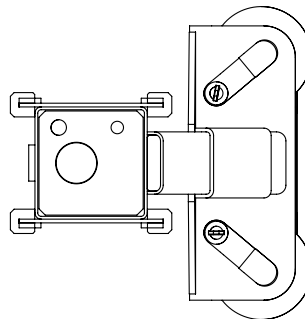
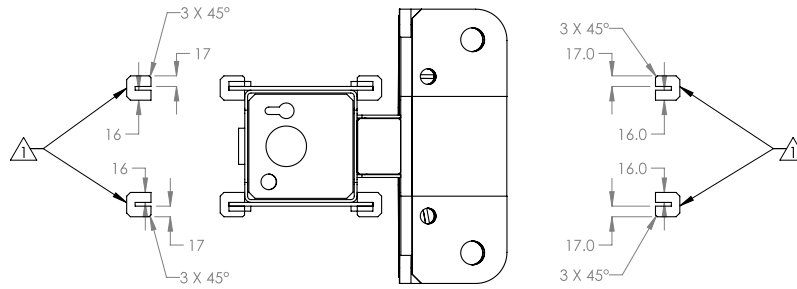

TOP VIEW

NOTE: UNLESS OTHERWISE SPECIFIED

1. NOTE ORIENTATION OF PLASTIC GUIDE BLOCK

BP BendPak
 1645 LEMONWOOD DR.
 SANTA PAULA, CA 93060

TITLE: 10AP-SRT LIFT HEAD ASSEMBLY

SIZE: DWG. NO. **A** 5216194xxx1498 REV **E**

SCALE: 1:7 SHEET 2 OF 2

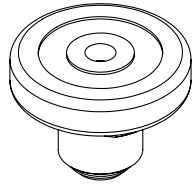

ISOMETRIC VIEW
FOR REFERENCE ONLY
DO NOT SCALE

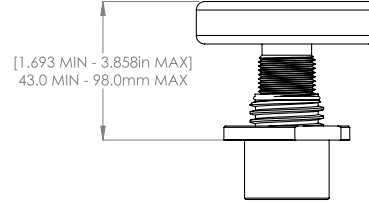
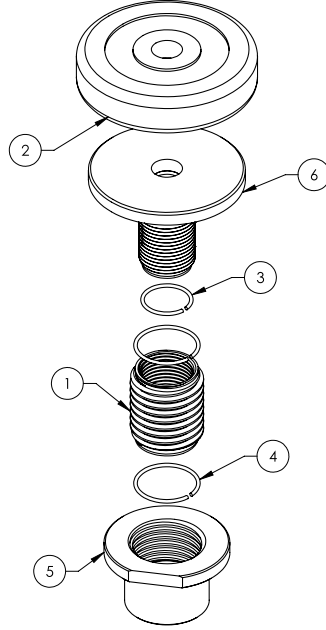

WHERE USED
XPR-9 SERIES
10AP SERIES

NOTE: UNLESS OTHERWISE SPECIFIED

- REFER TO MODEL FOR ADDITIONAL INFORMATION
- SEE SHIPPING INSTRUCTIONS FOR FINAL PACKAGING
- ASSEMBLE ITEMS AS SHOWN

NEXT ASSEMBLY
5250037
5250329
5250343
5250344
5250346
5250347

ITEM NO.	PART NUMBER	DESCRIPTION	QTY.	REV
1	5746692	INNER SCREW	1	C
2	5715052	ROUND LIFT PAD ADAPTER POLYURETHANE PAD	1	A
3	5540025	S RING Ø35mm	1	A
4	5540026	S RING Ø45mm	2	A
5	5746693	ROUND LIFT PAD SCREW ADAPTOR	1	D
6	5601986	ROUND LIFT PAD ADAPTOR WELDMENT	1	A

DO NOT SCALE DRAWING		NAME	DATE	 1645 LEMONWOOD DR. SANTA PAULA, CA 93060
DRAWN	CA	03/23/2023		
CHECKED				TITLE: ROUND ADJUSTABLE LIFT PAD ASSEMBLY
THIRD ANGLE PROJECTION				
DIMENSIONS ARE IN MM				SIZE DWG. NO. REV A 5216239 A
PROPRIETARY AND CONFIDENTIAL THE DESIGN OR DRAWING IS THE PROPERTY OF BENDPAK INC. ANY REPRODUCTION IN PART OR AS A WHOLE WITHOUT THE WRITTEN PERMISSION OF BENDPAK INC. IS PROHIBITED.				SCALE: 1:3 SHEET 1 OF 1

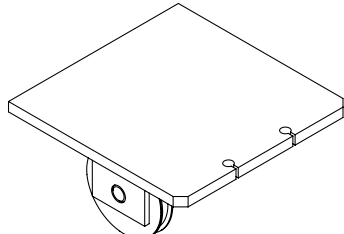

ISOMETRIC VIEW
FOR REFERENCE ONLY
DO NOT SCALE

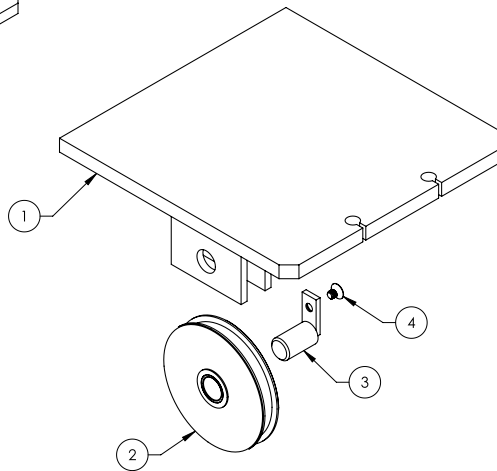

WHERE USED
10AP-SRT

NOTE: UNLESS OTHERWISE SPECIFIED

- REFER TO MODEL FOR ADDITIONAL INFORMATION
- SEE SHIPPING INSTRUCTIONS FOR FINAL PACKAGING
- ASSEMBLE ITEMS AS SHOWN

NEXT ASSEMBLY
5260693xxx149 8

ITEM NO.	PART NUMBER	DESCRIPTION	QTY.	REV
1	5620768xxx14 98	10AP-SRT TOP PLATE WELDMENT	1	D
2	5575068	10AP 100mm SHEAVE ASSEMBLY	1	B
3	5620143	D2-10, 10AP CABLE SHEAVE PIN WELDMENT	1	C
4	5530366	FHSS M6 x 1.0 x 8	1	-

DO NOT SCALE DRAWING		NAME	DATE	 1645 LEMONWOOD DR. SANTA PAULA, CA 93060
DRAWN	RK	02/27/2023		
CHECKED				TITLE: 10AP-SRT TOP PLATE ASSEMBLY
THIRD ANGLE PROJECTION				
DIMENSIONS ARE IN MM				SIZE DWG. NO. REV A 5216193xxx1498 D
PROPRIETARY AND CONFIDENTIAL THE DESIGN OR DRAWING IS THE PROPERTY OF BENDPAK INC. ANY REPRODUCTION IN PART OR AS A WHOLE WITHOUT THE WRITTEN PERMISSION OF BENDPAK INC. IS PROHIBITED.				SCALE: 1:3 SHEET 1 OF 1

12AP-SRT

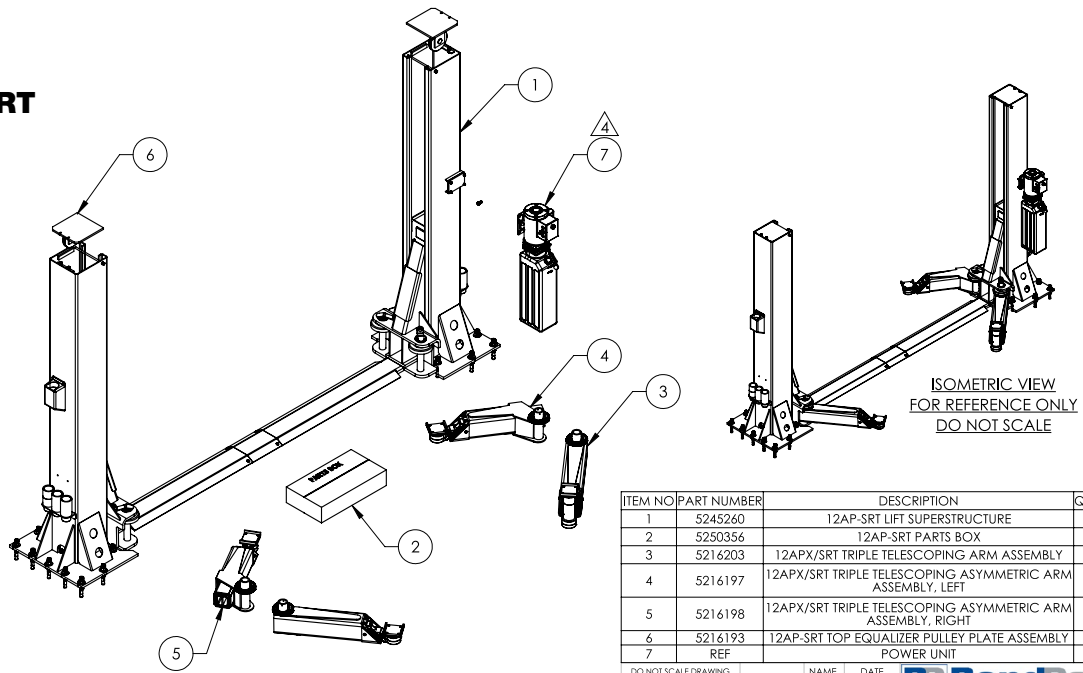

ITEM NO	PART NUMBER	DESCRIPTION	QTY	REV
1	5245260	12AP-SRT LIFT SUPERSTRUCTURE	1	D
2	5250356	12AP-SRT PARTS BOX	1	D
3	5216203	12APX/SRT TRIPLE TELESCOPING ARM ASSEMBLY	2	D
4	5216197	12APX/SRT TRIPLE TELESCOPING ASYMMETRIC ARM ASSEMBLY, LEFT	1	D
5	5216198	12APX/SRT TRIPLE TELESCOPING ASYMMETRIC ARM ASSEMBLY, RIGHT	1	D
6	5216193	12AP-SRT TOP EQUALIZER PULLEY PLATE ASSEMBLY	2	C
7	REF	POWER UNIT	1	-

- NOTE: UNLESS OTHERWISE SPECIFIED . . .**
- REFER TO MODEL FOR ADDITIONAL INFORMATION
 - SEE COLORS & GRAPHICS FOR LABEL PLACEMENT
 - SEE SHIPPING INSTRUCTIONS FOR FINAL PACKAGING
 - POWER UNIT REFERENCE ON PURCHASE ORDER

DO NOT SCALE DRAWING

NAME: **BP BendPak** DATE: 11/07/2022
 DRAWN: RK
 CHECKED:

1645 LEMONWOOD DR.
 SANTA PAULA, CA 93060

TITLE: 12AP-SRT PRODUCTION LIFT VER A

THIRD ANGLE PROJECTION

SIZE: DWG. NO. **A** 5260693 REV **D**

SCALE: 1:30 SHEET 1 OF 3

PROPRIETARY AND CONFIDENTIAL
 THE INFORMATION CONTAINED HEREIN IS THE SOLE PROPERTY OF BENDPAK INC. REPRODUCTION IN PART OR AS A WHOLE WITHOUT THE WRITTEN PERMISSION OF BENDPAK INC. IS PROHIBITED.

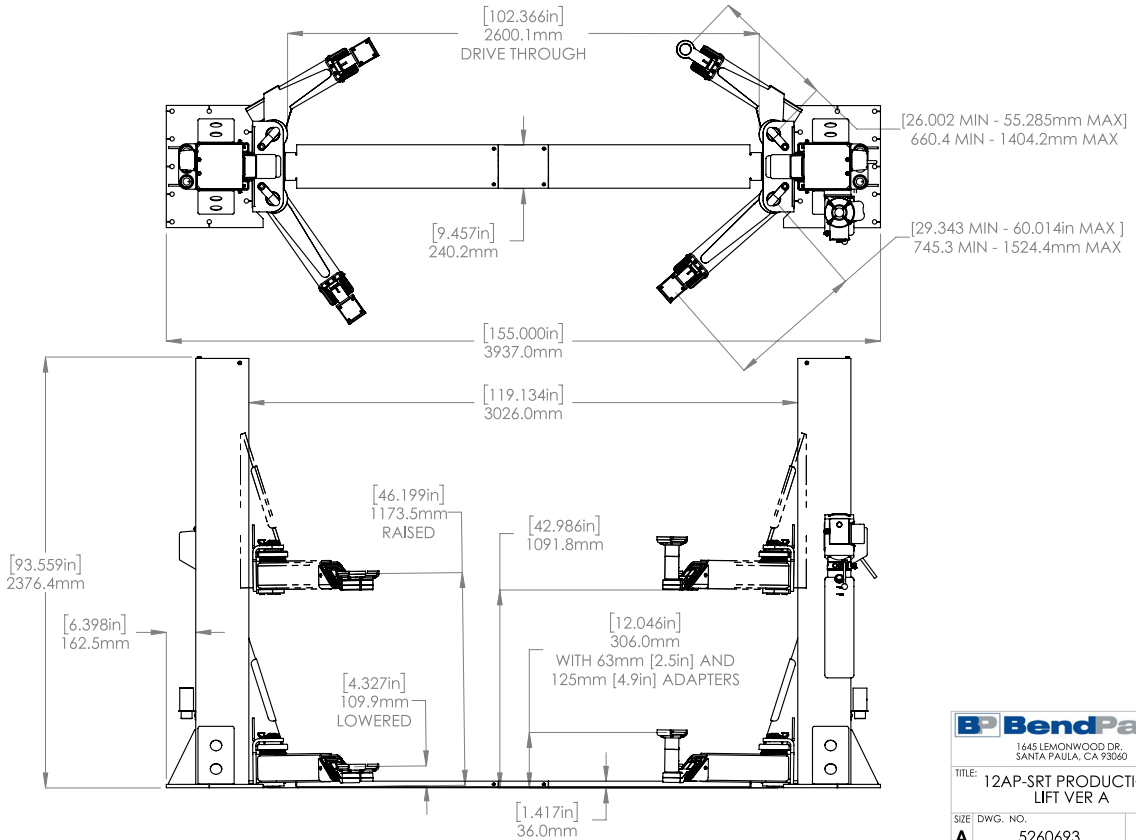

BP BendPak
 1645 LEMONWOOD DR.
 SANTA PAULA, CA 93060

TITLE: 12AP-SRT PRODUCTION LIFT VER A

SIZE: DWG. NO. **A** 5260693 REV **D**

SCALE: 1:25 SHEET 2 OF 3

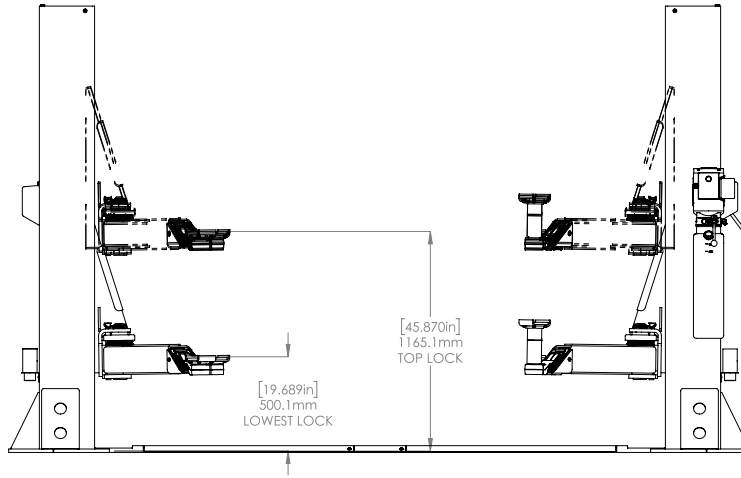

1. SAFETY LOCK POSITIONS: 8
2. SPACED EVERY: 95.0mm / 3.740"

BendPak.	
<small>1645 LEMONWOOD DR. SANTA PAULA, CA 95060</small>	
TITLE: 12AP-SRT PRODUCTION LIFT VER A	
SIZE DWG. NO.	REV
A 5260693	D
SCALE: 1:20 SHEET 3 OF 3	

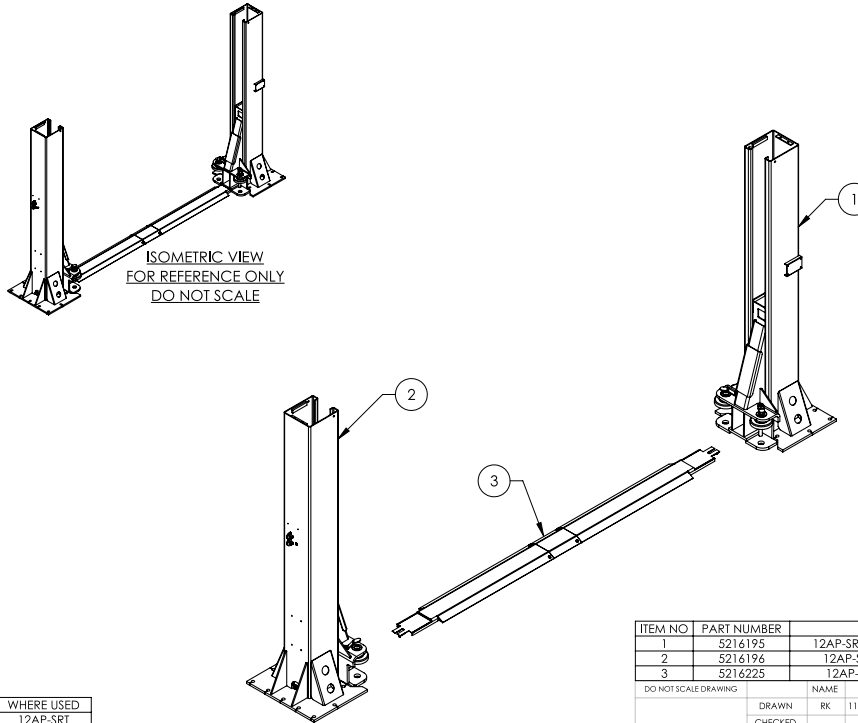

WHERE USED
12AP-SRT

- NOTE: UNLESS OTHERWISE SPECIFIED**
1. REFER TO MODEL FOR ADDITIONAL INFORMATION
 2. SEE SHIPPING INSTRUCTIONS FOR FINAL PACKAGING
 3. ASSEMBLE ITEMS AS SHOWN

NEXT ASSEMBLY
5260693

ITEM NO	PART NUMBER	DESCRIPTION	QTY	REV
1	5216195	12AP-SRT POWER SIDE POST ASSEMBLY	1	D
2	5216194	12AP-SRT OFF SIDE POST ASSEMBLY	1	D
3	5216225	12AP-SRT FLOOR PLATE ASSEMBLY	1	B

DO NOT SCALE DRAWING	NAME	DATE	BendPak.
	RK	11/07/2022	
DIMENSIONS ARE IN MM	THIRD ANGLE PROJECTION		<small>1645 LEMONWOOD DR. SANTA PAULA, CA 95060</small>
	TITLE: 12AP-SRT LIFT SUPERSTRUCTURE		
	SIZE DWG. NO.	REV	
	A 5245260	D	
	SCALE: 1:30		SHEET 1 OF 1

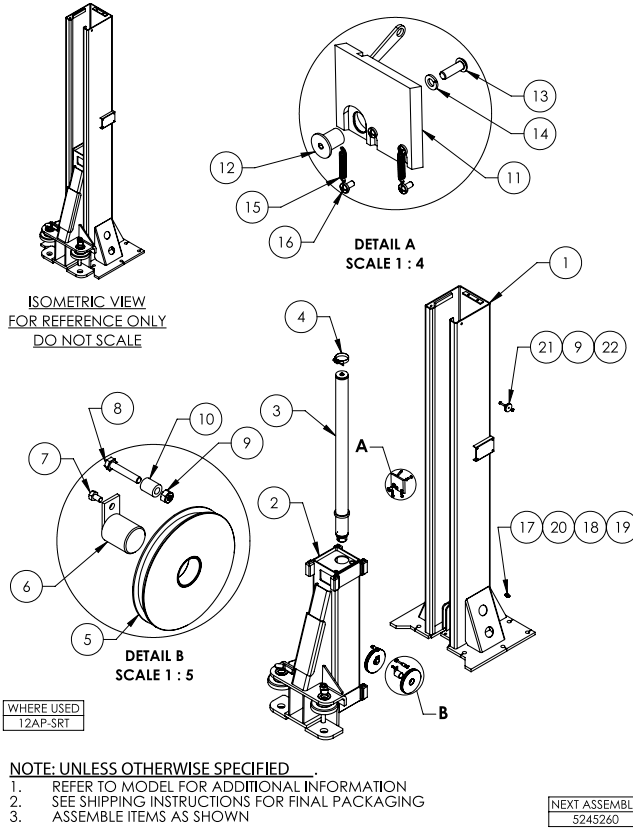

ITEM NO	PART NUMBER	DESCRIPTION	QTY	REV
1	5401893	12AP-SRT POWER SIDE POST WELDMENT	1	C
2	5216194	12AP-SRT LIFT HEAD ASSEMBLY	1	D
3	5502056	CYLINDER ASSEMBLY Ø2.5 x 42	1	C
4	5701115	CYLINDER CLAMP ASSY-74-79	1	A
5	5575113	12AP, D2/XPR-12/15/18 SHEAVE ASSEMBLY	2	E
6	5620142	12AP, D2-12/15, XPR-12C/12FD/15/18C CABLE SHEAVE PIN WELDMENT	2	A
7	5530181	HHB M6 x 1.0 x 10 FT, CL 10.9	2	-
8	5530248	HHB M8 x 1.25 x 45	2	A
9	5535001	NUT M8 x 1.25 NL, CL10.9	3	-
10	5746711	12AP-SRT SHEAVE PLATE SPACER	2	A
11	5601953	12AP-SRT POWER SIDE SAFETY WELDMENT	1	A
12	5746494	10/12AP SAFETY PIVOT PIN	1	C
13	5530414	BHSS M8 x 1.25 x 25 CL10.9	1	A
14	5545202	WASHER M8 x Ø15 SL, CL10.9	1	A
15	5540047	EXTENSION SPRING Ø6.35 x 38mm	2	C
16	5530045	BHPS M5 x 0.8 x 10 FT, CL 8.8	4	B
17	5575074	10/12AP SAFETY CABLE ROLLER	1	A
18	5565350	10/12AP/D2/GP/PCL/XPR/ PL-7000 SAFETY SHEAVE SPACER	1	C
19	5530756	HHB M6 x 1.0 x 25 FT, CL 10.9	1	B
20	5535357	NUT M6 x 1.0 NL, CL10.9	1	-
21	5575325	Ø50mm SAFETY SHEAVE	1	A
22	5530407	BHSS M8 x 1.25 x 40 FT, CL 10.9	1	-

DO NOT SCALE DRAWING

NAME: RK DATE: 11/07/2022

CHECKED: [Signature]

DIMENSIONS ARE IN MM

THIRD ANGLE PROJECTION

PROPRIETARY AND CONFIDENTIAL
THE INFORMATION CONTAINED HEREIN IS THE SOLE PROPERTY OF BENDPAK INC. ANY REPRODUCTION PART OR IN WHOLE WITHOUT THE WRITTEN PERMISSION OF BENDPAK INC. IS PROHIBITED.

BendPak
1645 LEMONWOOD DR.
SANTA PAULA, CA 93060

TITLE: 12AP-SRT POWER SIDE POST ASSEMBLY

SIZE: A DWG. NO.: 5216195 REV: D

SCALE: 1:25 SHEET 1 OF 1

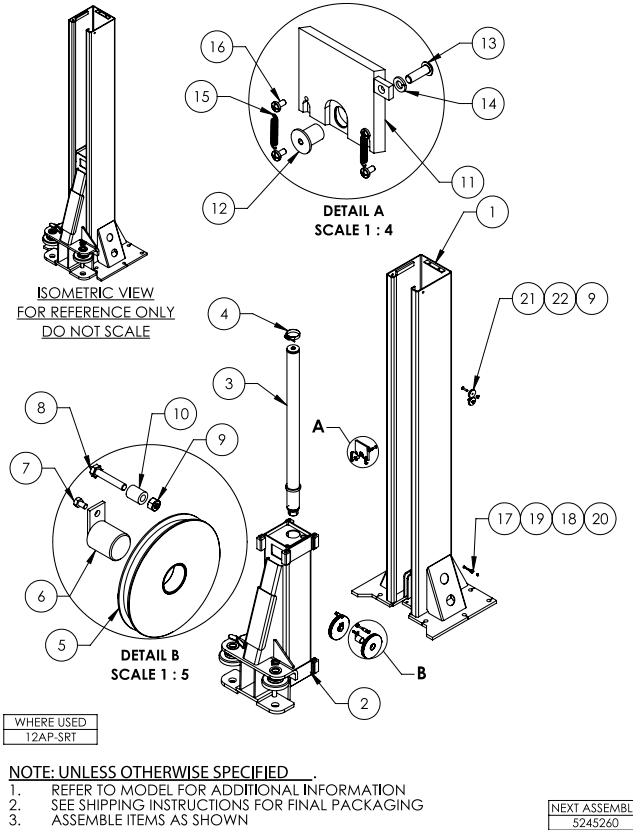

ITEM NO	PART NUMBER	DESCRIPTION	QTY	REV
1	5601894	12AP-SRT OFF SIDE POST WELDMENT	1	C
2	5216194	12AP-SRT LIFT HEAD ASSEMBLY	1	D
3	5502056	CYLINDER ASSEMBLY Ø2.5 x 42	1	C
4	5701115	CYLINDER CLAMP ASSY-74-79	1	-
5	5575113	12AP, D2/XPR-12/15/18 SHEAVE ASSEMBLY	2	E
6	5620142	12AP, D2-12/15, XPR-12C/12FD/15/18C CABLE SHEAVE PIN WELDMENT	2	A
7	5530181	HHB M6 x 1.0 x 10 FT, CL 10.9	2	-
8	5530248	HHB M8 x 1.25 x 45	2	-
9	5535001	NUT M8 x 1.25 NL, CL10.9	4	-
10	5746711	12AP-SRT SHEAVE PLATE SPACER	2	A
11	5601952	12AP-SRT OFF SIDE SAFETY BLOCK WELDMENT	1	A
12	5746494	10/12AP SAFETY PIVOT PIN	1	C
13	5530414	BHSS M8 x 1.25 x 25 CL10.9	1	-
14	5545202	WASHER M8 x Ø15 SL, CL10.9	1	-
15	5540047	EXTENSION SPRING Ø6.35 x 38mm	2	C
16	5530045	BHPS M5 x 0.8 x 10 FT, CL 8.8	4	B
17	5575074	10/12AP SAFETY CABLE ROLLER	1	A
18	5565350	10/12AP/D2/GP/PCL/XPR/ PL-7000 SAFETY SHEAVE SPACER	1	C
19	5530756	HHB M6 x 1.0 x 25 FT, CL 10.9	1	-
20	5535357	NUT M6 x 1.0 NL, CL10.9	1	-
21	5575325	Ø50mm SAFETY SHEAVE	2	A
22	5530407	BHSS M8 x 1.25 x 40 FT, CL 10.9	2	-

DO NOT SCALE DRAWING

NAME: RK DATE: 11/07/2022

CHECKED: [Signature]

DIMENSIONS ARE IN MM

THIRD ANGLE PROJECTION

PROPRIETARY AND CONFIDENTIAL
THE INFORMATION CONTAINED HEREIN IS THE SOLE PROPERTY OF BENDPAK INC. ANY REPRODUCTION PART OR IN WHOLE WITHOUT THE WRITTEN PERMISSION OF BENDPAK INC. IS PROHIBITED.

BendPak
1645 LEMONWOOD DR.
SANTA PAULA, CA 93060

TITLE: 12AP-SRT OFF SIDE POST ASSEMBLY

SIZE: A DWG. NO.: 5216196 REV: D

SCALE: 1:25 SHEET 1 OF 1

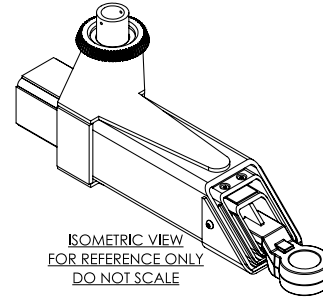
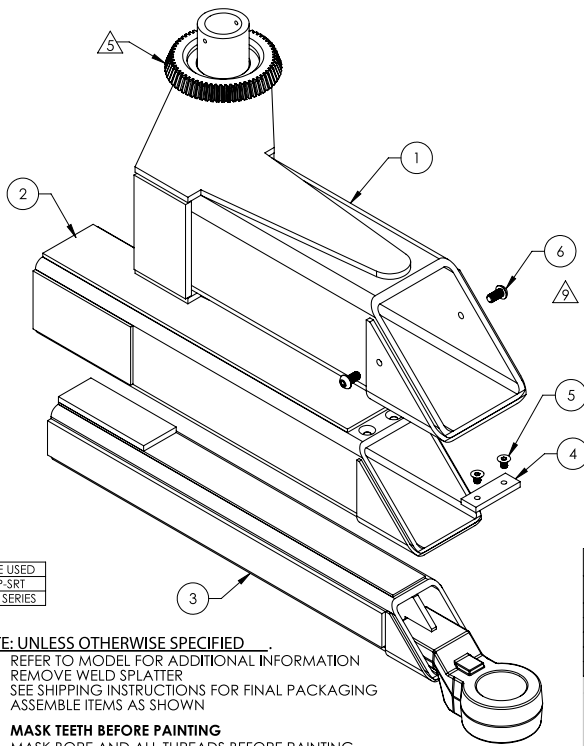

WHERE USED
12AP-SRT
12APX SERIES

NOTE: UNLESS OTHERWISE SPECIFIED

1. REFER TO MODEL FOR ADDITIONAL INFORMATION
2. REMOVE WELD SPLATTER
3. SEE SHIPPING INSTRUCTIONS FOR FINAL PACKAGING ASSEMBLY ITEMS AS SHOWN
- 4.
5. **MASK TEETH BEFORE PAINTING**
6. MASK BORE AND ALL THREADS BEFORE PAINTING
7. DIMENSIONS SHOWN ARE AFTER WELDING AND PAINTING
8. PAINT YELLOW (RAL-1018) 20% GLOSS
9. APPLY LOCTITE BLUE 242 AND CURE PER MANUFACTURE SPECIFICATION

NEXT ASSEMBLY
5260693
5260694
5260695

ITEM NO.	PART NUMBER	DESCRIPTION	QTY	REV
1	5601899	12APX/SRT ASYMMETRIC ARM WELDMENT, OUTER SECTION, LEFT	1	D
2	5601898	12APX/SRT ASYMMETRIC ARM WELDMENT, MIDDLE SECTION	1	C
3	5601897	12APX/SRT ASYMMETRIC ARM WELDMENT, INNER SECTION	1	D
4	5737188	10/12AP MIDDLE ARM SECTION SLIDE STOP	1	B
5	5530382	FHSS M8 x 1.25 x 12 CL10.9	2	-
6	5530479	BHSS M10 x 1.5 x 20 FT. CL 10.9 B.O.	2	-

DO NOT SCALE DRAWING	NAME	DATE
		07/22/2022

DRAWN	RK	DATE
		07/22/2022

CHECKED	NAME	DATE

THIRD ANGLE PROJECTION	TITLE	SIZE	DWG. NO.	REV
	12APX/SRT TRIPLE TELESCOPING ASYMMETRIC ARM ASSEMBLY, LEFT	A	5216197	D

SCALE: 1:5 SHEET 1 OF 2

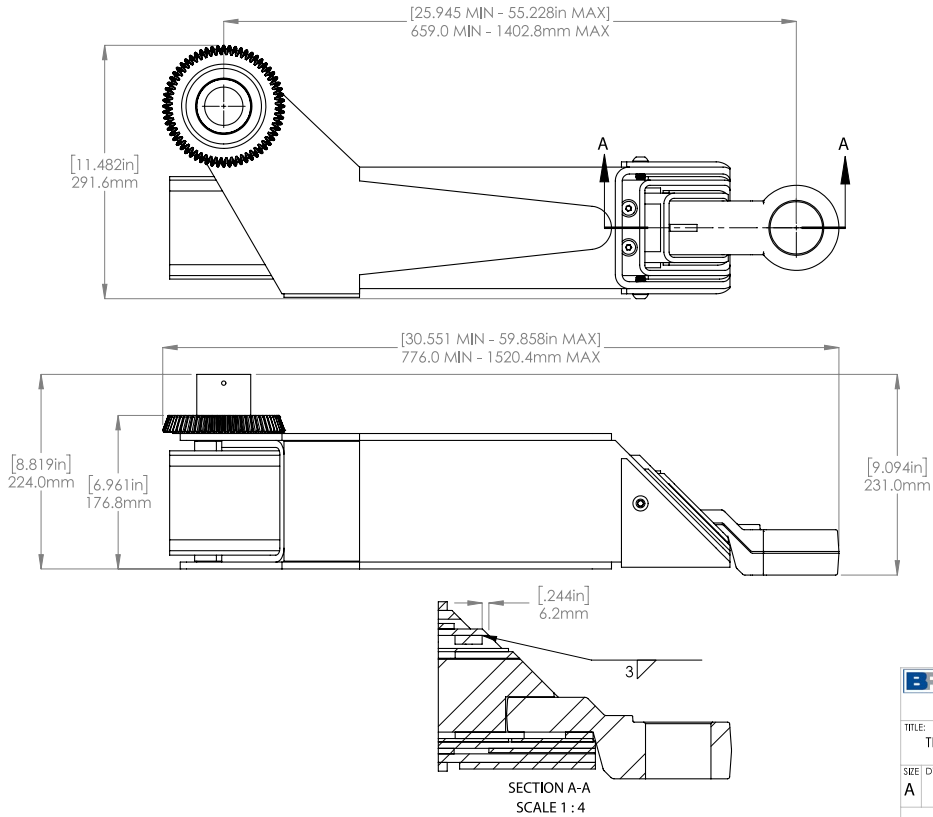

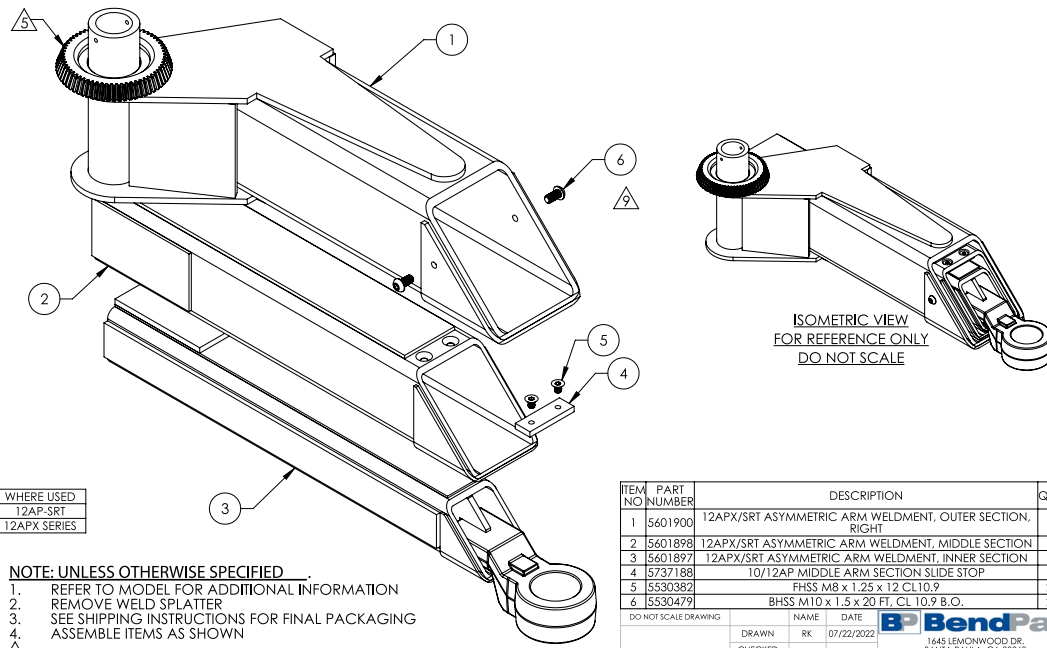

WHERE USED
12AP-SRT
12APX SERIES

- NOTE: UNLESS OTHERWISE SPECIFIED**
- REFER TO MODEL FOR ADDITIONAL INFORMATION
 - REMOVE WELD SPLATTER
 - SEE SHIPPING INSTRUCTIONS FOR FINAL PACKAGING ASSEMBLY ITEMS AS SHOWN
 - 5. MASK TEETH BEFORE PAINTING**
MASK BORE AND ALL THREADS BEFORE PAINTING
DIMENSIONS SHOWN ARE AFTER WELDING AND PAINTING
PAINT YELLOW (RAL-1018) 20% GLOSS
 - APPLY LOCTITE BLUE 242 AND CURE PER MANUFACTURE SPECIFICATION

NEXT ASSEMBLY
5260693
5260694
5260695

ITEM NO	PART NUMBER	DESCRIPTION	QTY	REV
1	5601900	12APX/SRT ASYMMETRIC ARM WELDMENT, OUTER SECTION, RIGHT	1	D
2	5601898	12APX/SRT ASYMMETRIC ARM WELDMENT, MIDDLE SECTION	1	C
3	5601897	12APX/SRT ASYMMETRIC ARM WELDMENT, INNER SECTION	1	D
4	5737188	10/12AP MIDDLE ARM SECTION SLIDE STOP	1	B
5	5530382	FHSS M8 x 1.25 x 12 CL10.9	2	-
6	5530479	BHSS M10 x 1.5 x 20 FT. CL 10.9 B.O.	2	-

DO NOT SCALE DRAWING	NAME	DATE	 1445 LEMONWOOD DR. SANTA PAULA, CA 93060
DRAWN	RK	07/22/2022	
CHECKED			
DIMENSIONS ARE IN MM			TITLE: 12APX/SRT TRIPLE TELESCOPING ASYMMETRIC ARM ASSEMBLY, RIGHT SIZE DWG. NO. A 5216198 REV D SCALE: 1:5 SHEET 1 OF 2

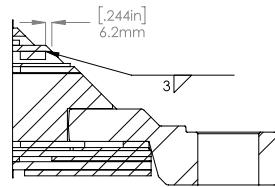
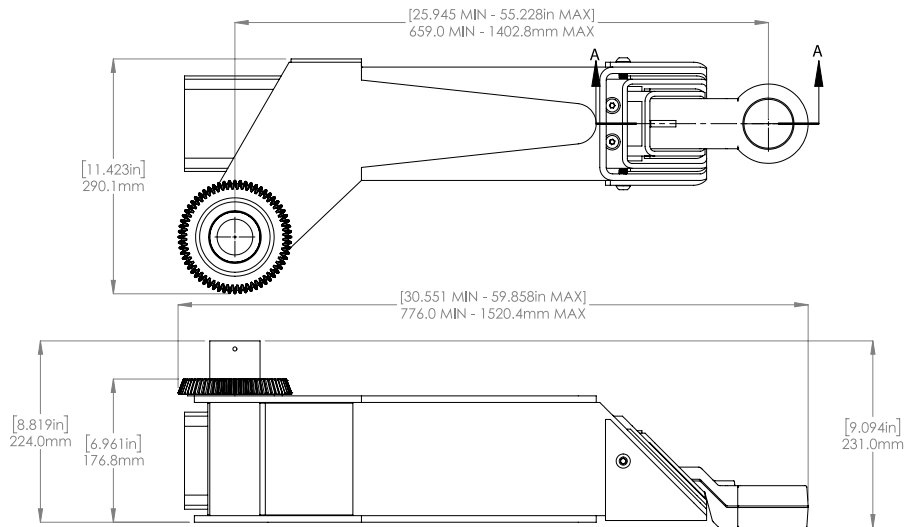

SECTION A-A
SCALE 1:4

BendPak	
1445 LEMONWOOD DR. SANTA PAULA, CA 93060	
TITLE: 12APX/SRT TRIPLE TELESCOPING ASYMMETRIC ARM ASSEMBLY, RIGHT	
SIZE DWG. NO. A 5216198	REV D
SCALE: 1:5 SHEET 2 OF 2	

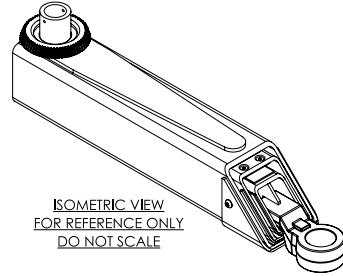
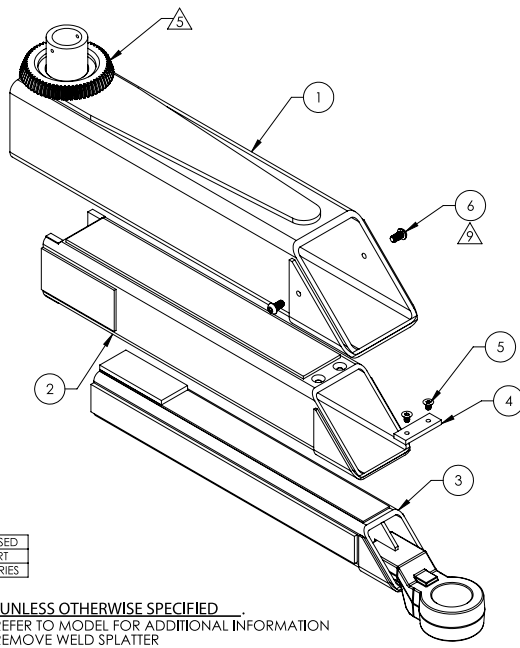

WHERE USED
12AP-SRT
12APX SERIES

- NOTE: UNLESS OTHERWISE SPECIFIED**
- REFER TO MODEL FOR ADDITIONAL INFORMATION
 - REMOVE WELD SPLATTER
 - SEE SHIPPING INSTRUCTIONS FOR FINAL PACKAGING ASSEMBLE ITEMS AS SHOWN
 - MASK TEETH BEFORE PAINTING**
 - MASK BORE AND ALL THREADS BEFORE PAINTING
 - DIMENSIONS SHOWN ARE AFTER WELDING AND PAINTING
 - PAINT YELLOW (RAL-1018) 20% GLOSS
 - APPLY LOCTITE BLUE 242 AND CURE PER MANUFACTURE SPECIFICATION

ITEM NO	PART NUMBER	DESCRIPTION	QTY	REV
1	5601907	12APX/SRT ARM WELDMENT, OUTER SECTION	1	D
2	5601908	12APX/SRT ARM WELDMENT, MIDDLE SECTION	1	D
3	5601909	12APX/SRT ARM WELDMENT, INNER SECTION	1	D
4	5737188	10/12AP MIDDLE ARM SECTION SLIDE STOP	1	B
5	5530382	FHSS M8 x 1.25 x 12 CL10.9	2	-
6	5530479	BHSS M10 x 1.5 x 20 FT. CL 10.9 B.O.	2	-

NEXT ASSEMBLY
5260693
5260694
5260695

DO NOT SCALE DRAWING

DRAWN	NAME	DATE
RK		03/23/2022

CHECKED

THIRD ANGLE PROJECTION

1645 LEMONWOOD DR.
SANTA PAULA, CA 93060

TITLE: 12APX/SRT TRIPLE TELESCOPING ARM ASSEMBLY

SIZE: DWG. NO. 5216203 REV D

SCALE: 1:6 SHEET 1 OF 2

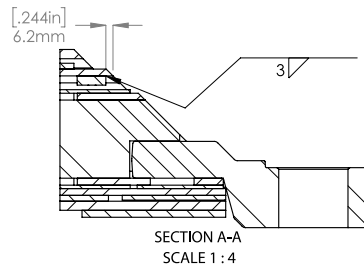
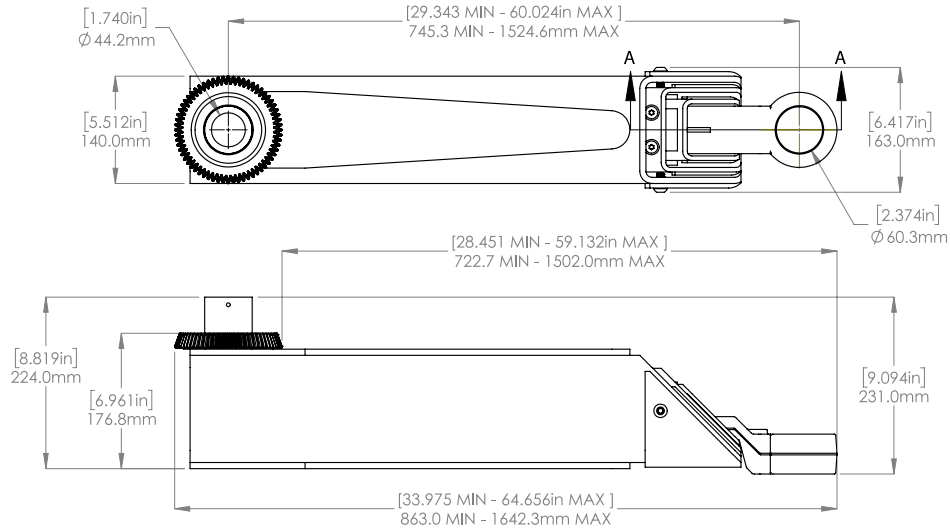

BendPak.

1645 LEMONWOOD DR.
SANTA PAULA, CA 93060

TITLE: 12APX/SRT TRIPLE TELESCOPING ARM ASSEMBLY

SIZE: DWG. NO. 5216203 REV D

SCALE: 1:6 SHEET 2 OF 2

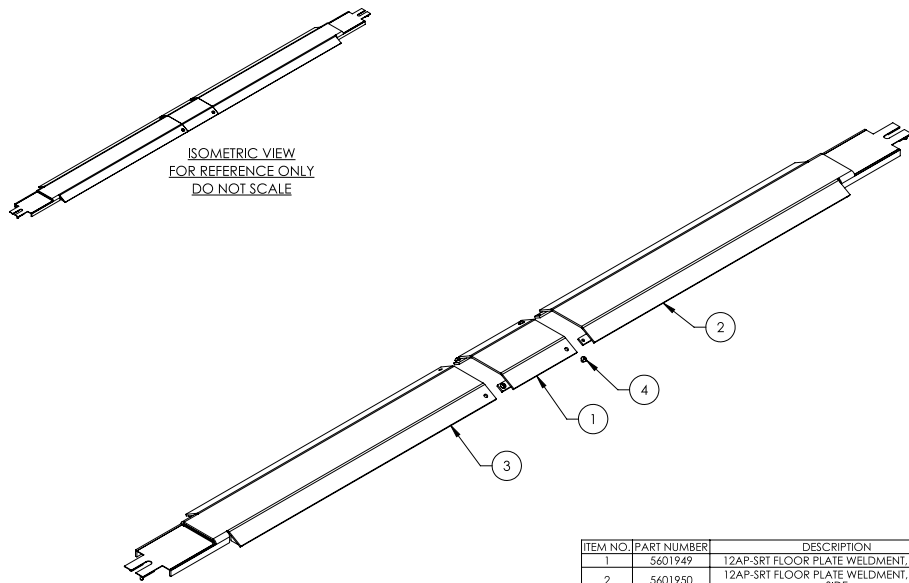

ISOMETRIC VIEW
FOR REFERENCE ONLY
DO NOT SCALE

WHERE USED
12AP-SRT

NOTE: UNLESS OTHERWISE SPECIFIED
1. REFER TO MODEL FOR ADDITIONAL INFORMATION
2. SEE SHIPPING INSTRUCTIONS FOR FINAL PACKAGING

ITEM NO.	PART NUMBER	DESCRIPTION	QTY.	REV
1	5601949	12AP-SRT FLOOR PLATE WELDMENT, MIDDLE	1	A
2	5601950	12AP-SRT FLOOR PLATE WELDMENT, POWER SIDE	1	B
3	5601951	12AP-SRT FLOOR PLATE WELDMENT, OFF SIDE	1	B
4	5530480	BHSS M10 x 1.5 x 12 FT. CL 10.9	4	-

DO NOT SCALE DRAWING

NAME	DATE	 1645 LEMONWOOD DR. SANTA PAULA, CA 93060
DRAWN	04/10/2023	
CHECKED		
THIRD ANGLE PROJECTION	TITLE:	12AP-SRT FLOOR PLATE ASSEMBLY
SIZE	DWG. NO.	REV
A	5216225	B
SCALE: 1:12		SHEET 1 OF 1

PROPRIETARY AND CONFIDENTIAL
THE INFORMATION CONTAINED HEREIN IS THE PROPERTY OF BENDPAK INC. AND IS TO BE USED ONLY FOR THE PARTS LISTED HEREIN. REPRODUCTION OR TRANSMISSION OF THIS INFORMATION WITHOUT THE WRITTEN PERMISSION OF BENDPAK INC. IS PROHIBITED.

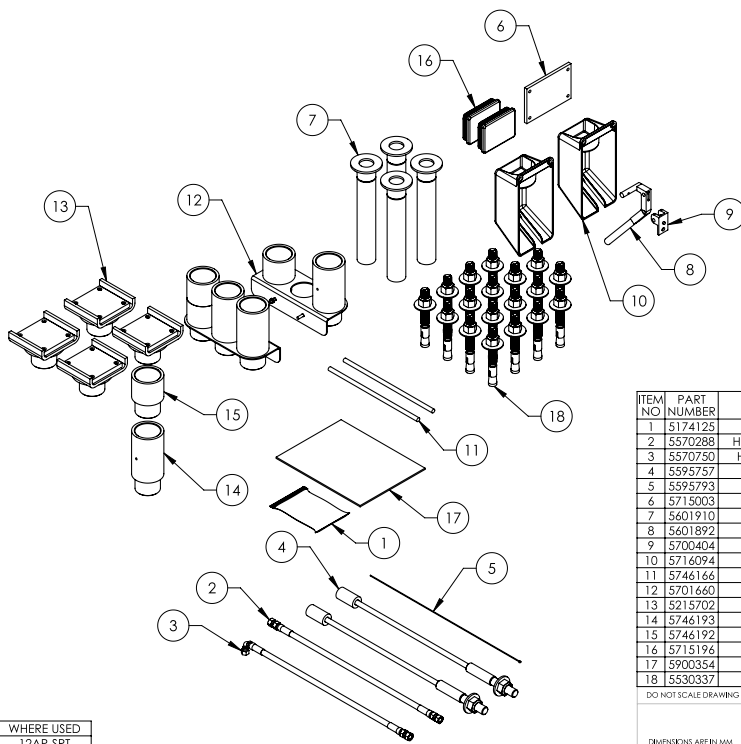

WHERE USED
12AP-SRT

NOTE: UNLESS OTHERWISE SPECIFIED
1. REFER TO MODEL FOR ADDITIONAL INFORMATION
2. INSERT PARTS BAG INTO PARTS BOX FOR SHIPMENT
3. HOSES AND CABLES SHOWN REPRESENTATIONAL FORM

NEXT ASSEMBLY
5260693

ITEM NO.	PART NUMBER	DESCRIPTION	QTY.	REV
1	5174125	10/12AP-SRT PARTS BAG	1	D
2	5570288	HYDRAULIC HOSE ASSEMBLY Ø6.35 x 3321mm DS	1	B
3	5570750	HYDRAULIC HOSE ASSEMBLY Ø6.4 x 1212mm SB	1	C
4	5595757	CABLE ASSEMBLY Ø12 x 7332mm ST	2	B
5	5595793	SAFETY CABLE Ø1.8 x 7773mm	1	A
6	5715003	POWER UNIT VIBRATION DAMPENER	1	B
7	5601910	12APX/SRT ARM LOCK PIN WELDMENT, Ø44	4	B
8	5601892	12AP-SRT SAFETY HANDLE WELDMENT	1	B
9	5700404	AP SAFETY PIVOT HOLDER	1	C
10	5716094	12AP-SRT PLASTIC SAFETY COVER	2	C
11	5746166	DOUBLE THREADED ROD M10 x 1.5 x 295	2	B
12	5701660	HEIGHT ADAPTER HOLDER, 60mm PIN	2	B
13	5215702	CRADLE LIFT PAD LARGE ADAPTER ASSEMBLY	4	F
14	5746193	ARM ADAPTER, LONG	4	E
15	5746192	ARM ADAPTER, MEDIUM	4	F
16	5715194	POLYETHYLENE COVER BLOCK 105 x 80	2	D
17	5900354	SRT INSTALLATION MANUAL	1	-
18	5530337	AB 3/4' x 6.3'	18	-

DO NOT SCALE DRAWING

NAME	DATE	 1645 LEMONWOOD DR. SANTA PAULA, CA 93060
DRAWN	12/29/2022	
CHECKED		
THIRD ANGLE PROJECTION	TITLE:	12AP-SRT PARTS BOX
SIZE	DWG. NO.	REV
A	5250356	D
SCALE: 1:10		SHEET 1 OF 1

PROPRIETARY AND CONFIDENTIAL
THE INFORMATION CONTAINED HEREIN IS THE PROPERTY OF BENDPAK INC. AND IS TO BE USED ONLY FOR THE PARTS LISTED HEREIN. REPRODUCTION OR TRANSMISSION OF THIS INFORMATION WITHOUT THE WRITTEN PERMISSION OF BENDPAK INC. IS PROHIBITED.

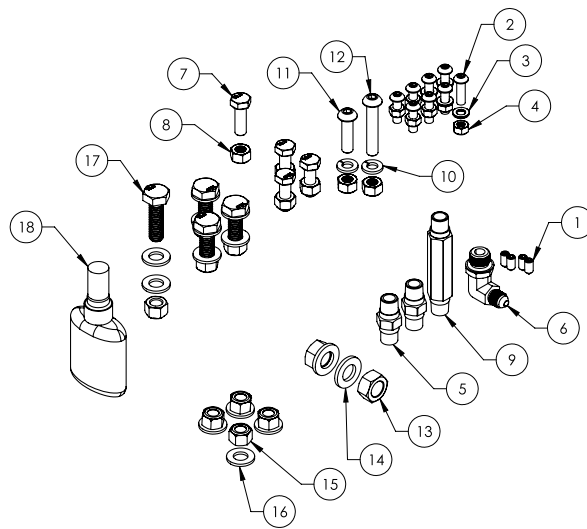

WHERE USED
10AP-SRT
12AP-SRT

NOTE: UNLESS OTHERWISE SPECIFIED
1. SEE SHIPPING INSTRUCTIONS FOR FINAL PACKAGING

ITEM NO	PART NUMBER	DESCRIPTION	QTY	REV
1	5530423	SSS M6 x 1.0 x 12 CONE, CL 10.9	4	-
2	5530065	BHSK M6 x 1.0 x 20 FT, CL 10.9	8	-
3	5545005	WASHER M6 x 12 FLAT, CL 10.9	4	-
4	5535357	NUT M6 x 1.0 NL, CL10.9	8	-
5	5550147	FTG NPL -04 JIC x -04 NPT	2	-
6	5550103	FTG ELB -04 JIC -06 ORB	1	-
7	5530010	HHB M8 x 1.25 x 25 FT, CL 10.9	4	-
8	5535001	NUT M8 x 1.25 NL, CL10.9	6	-
9	5550228	FTG NPL-04 NPTF x -04 JIC, 3.25 LONG	1	-
10	5545202	WASHER M8 x Ø15 SL, CL10.9	2	-
11	5530412	BHSK M8 x 1.25 x 30 CL10.9	1	-
12	5530413	BHSK M8 x 1.25 x 45 CL10.9	1	-
13	5535354	NUT M12 x 1.75, CL 10.9	2	-
14	5545347	WASHER M12 x 24 FLAT, CL 10.9	2	-
15	5535013	NUT M10 x 1.5 NL, CL10.9	8	-
16	5545341	WASHER M10 x Ø20 FLAT, CL10.9	12	-
17	5530106	HHB M10 x 1.5 x 35 FT, CL 10.9	4	-
18	5580012	LIQUID PTFE THREAD SEALANT 50ml	1	-

DO NOT SCALE DRAWING

NAME DATE



DRAWN OR 12/29/2022

DIMENSIONS ARE IN MM



CHECKED

THIRD ANGLE PROJECTION

TITLE: 10/12AP-SRT PARTS BAG

SIZE DWG. NO. REV

A 5174125 D

SCALE: 1:3 SHEET 1 OF 1

NEXT ASSEMBLY
5250356
5250356xxx149
8

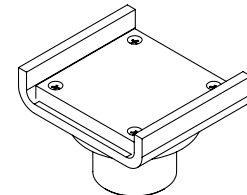
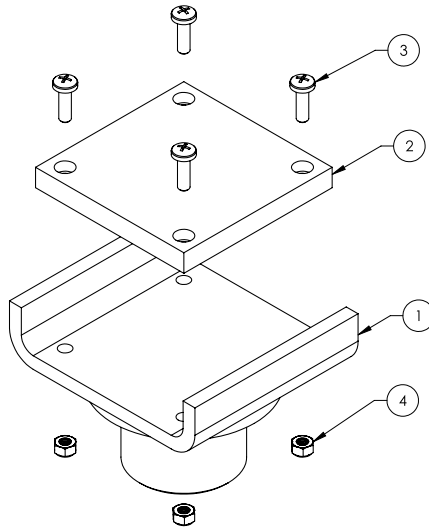

ISOMETRIC VIEW
FOR REFERENCE ONLY
DO NOT SCALE

WHERE USED
12AP SERIES
16AP SERIES
20AP SERIES
XPR-12FDL SERIES
XPR-12CL SERIES
XPR-15 SERIES
XPR-18 SERIES

NOTE: UNLESS OTHERWISE SPECIFIED
1. REFER TO MODEL FOR ADDITIONAL INFORMATION
2. SEE SHIPPING INSTRUCTIONS FOR FINAL PACKAGING
3. ASSEMBLE ITEMS AS SHOWN

ITEM NO	PART NUMBER	DESCRIPTION	QTY	REV
1	5601000	CRADLE LIFT PAD WELDMENT	1	D
2	5715020	CRADLE LIFT PAD LARGE POLYURETHANE PAD	1	C
3	5530022	PHPS M6 x 1 x 20mm ZPL	4	-
4	5535357	NUT M6 x 1.0 NL	4	-

DO NOT SCALE DRAWING

NAME DATE



DRAWN JM 06/24/2015

DIMENSIONS ARE IN MM



CHECKED

THIRD ANGLE PROJECTION

TITLE: CRADLE LIFT PAD LARGE ADAPTER ASSEMBLY

SIZE DWG. NO. REV

A 5215702 F

SCALE: 1:2 SHEET 1 OF 1

NEXT ASSEMBLY
5250254
5250253
5250254
5250254
5250257
5250258
5250259
5250314
5250314
5250356
5250357
5250358

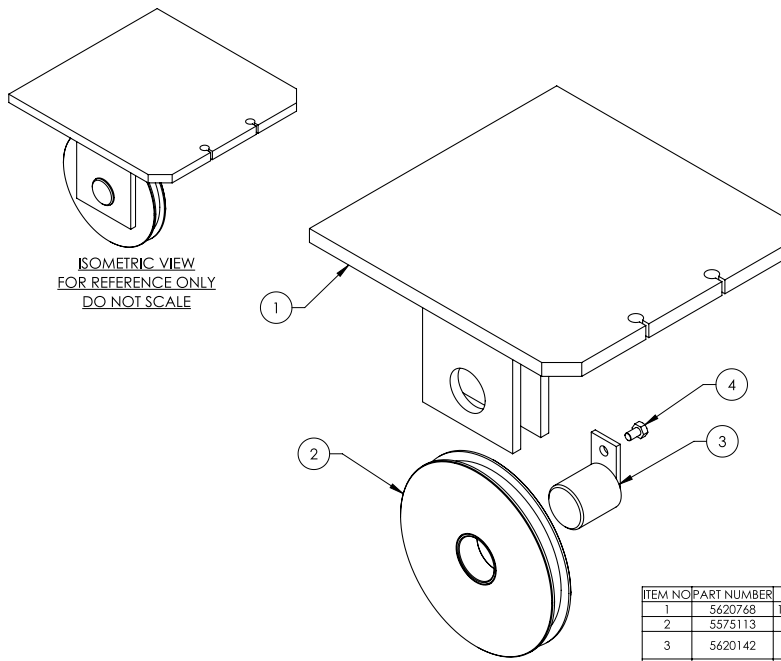

ISOMETRIC VIEW
FOR REFERENCE ONLY
DO NOT SCALE

WHERE USED
12AP-SRT

- NOTE: UNLESS OTHERWISE SPECIFIED**
1. REFER TO MODEL FOR ADDITIONAL INFORMATION
 2. SEE SHIPPING INSTRUCTIONS FOR FINAL PACKAGING
 3. ASSEMBLE ITEMS AS SHOWN

NEXT ASSEMBLY
5260693

ITEM NO	PART NUMBER	DESCRIPTION	QTY	REV
1	5620768	12AP-SRT TOP EQUALIZER PULLEY PLATE WELDMNT	1	C
2	5575113	12AP, D2/XPR-12/15/18 SHEAVE ASSEMBLY	1	E
3	5620142	12AP, D2-12/15, XPR-12C/12FD/15/18C CABLE SHEAVE PIN WELDMNT	1	A
4	5530181	HHB M6 x 1.0 x 10	1	--

DO NOT SCALE DRAWING		NAME	DATE	 1645 LEMONWOOD DR. SANTA PAULA, CA 93060
DRAWN	RK	11/08/2022		
CHECKED	OR	05/30/2023		

DIMENSIONS ARE IN MM		THIRD ANGLE PROJECTION	TITLE:	REV
			12AP-SRT TOP EQUALIZER PULLEY PLATE ASSEMBLY	C
			SIZE: DWG. NO. A 5216193	
		<small>PROPRIETARY AND CONFIDENTIAL THE INFORMATION CONTAINED IN THIS DRAWING IS THE SOLE PROPERTY OF BENDPAK INC. ANY REPRODUCTION IN PART OR AS A WHOLE WITHOUT THE WRITTEN PERMISSION OF BENDPAK INC. IS PROHIBITED.</small>	SCALE: 1:3	SHEET 1 OF 1

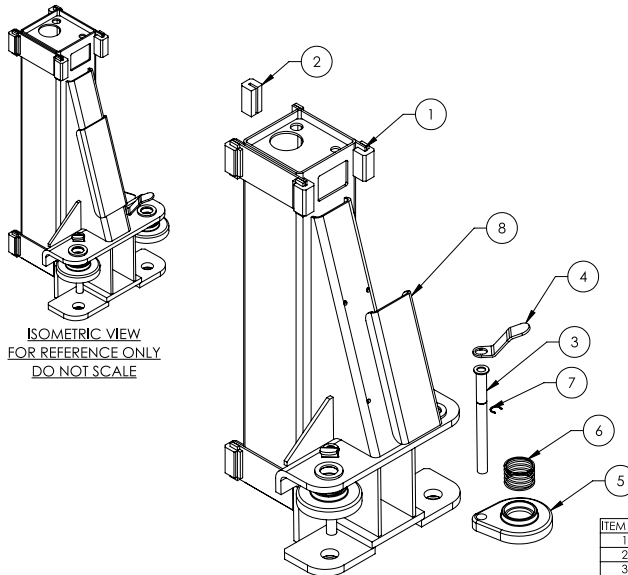

ISOMETRIC VIEW
FOR REFERENCE ONLY
DO NOT SCALE

WHERE USED
12AP-SRT

- NOTE: UNLESS OTHERWISE SPECIFIED**
1. REFER TO MODEL FOR ADDITIONAL INFORMATION
 2. SEE SHIPPING INSTRUCTIONS FOR FINAL PACKAGING
 3. ASSEMBLE ITEMS AS SHOWN

NEXT ASSEMBLY
5216195
5216196

ITEM NO	PART NUMBER	DESCRIPTION	QTY	REV
1	5601895	12AP-SRT LIFT HEAD WELDMNT	1	D
2	5716001	2 POST GUIDE BLOCK	8	H
3	5601896	12AP-SRT ARM LOCK GUIDE ROD WELDMNT	2	C
4	5701700	10/12AP ARM LOCK RELEASE HANDLE	2	C
5	5701701	10/12AP ARM INTERNAL FULL CIRCLE GEAR STOP	2	C
6	5540044	COMPRESSION SPRING Ø74 x 50mm	2	C
7	5540006	SNAP RING TRIARC 5103-100	2	A
8	5930004	12APX LIFT HEAD GUSSET COVER	1	B

DO NOT SCALE DRAWING		NAME	DATE	 1645 LEMONWOOD DR. SANTA PAULA, CA 93060
DRAWN	RK	11/07/2022		
CHECKED	OR			

DIMENSIONS ARE IN MM		THIRD ANGLE PROJECTION	TITLE:	REV
			12AP-SRT LIFT HEAD ASSEMBLY	D
			SIZE: DWG. NO. A 5216194	
		<small>PROPRIETARY AND CONFIDENTIAL THE INFORMATION CONTAINED IN THIS DRAWING IS THE SOLE PROPERTY OF BENDPAK INC. ANY REPRODUCTION IN PART OR AS A WHOLE WITHOUT THE WRITTEN PERMISSION OF BENDPAK INC. IS PROHIBITED.</small>	SCALE: 1:10	SHEET 1 OF 2

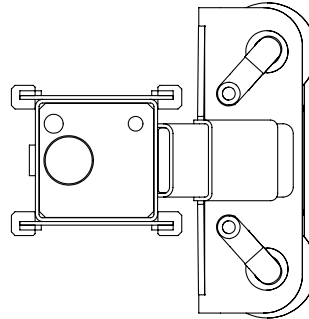
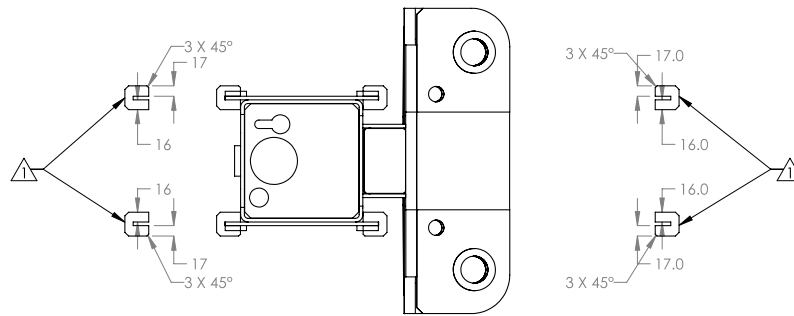

TOP VIEW

NOTE: UNLESS OTHERWISE SPECIFIED.
 ⚠ NOTE ORIENTATION OF PLASTIC GUIDE BLOCK

BP BendPak.		
1445 LEMONWOOD DR. SANTA PAULA, CA 95060		
TITLE: 12AP-SRT LIFT HEAD ASSEMBLY		
SIZE	DWG. NO.	REV
A	5216194	D
SCALE: 1:7		SHEET 2 OF 2

Automotive Lift Institute (ALI) Store

You probably checked the [ALI's Directory of Certified Lifts](http://www.autolift.org/ali-directory-of-certified-lifts/) before making your most recent Lift purchase, but did you know the [ALI Store](http://www.autolift.org/ali-store/) offers a wide variety of professional, easy-to-use, and reasonably priced training and safety materials that will make your garage a safer place to work?

The ALI Store is your trusted source for workplace safety!



Lifting It Right Online Certificate Course. Make *sure* you and your people are lifting vehicles the right way.



ALI Lift Inspector Certification Program Registration. Become a Certified Lift Inspector.

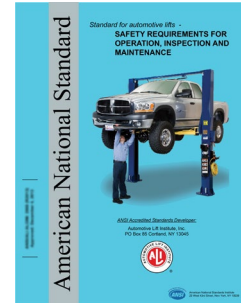

ANSI/ALI ALOIM Standard for Automotive Lifts. Safety Requirements for Operation, Inspection, and Maintenance.

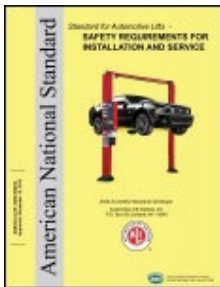

ANSI/ALI ALIS Standard. Safety Requirements for Installation and Service.

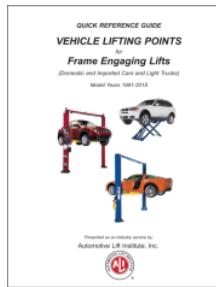

Guide to Hitting Vehicle Lifting Points for Frame-Engaging Lifts. Don't eyeball your lifting points, *know* where they are.



Lift Operator Safety Materials. Five safety documents in a single package.

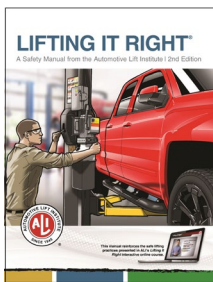

Lifting It Right. A hardcopy version of the *Lifting It Right* safety manual from the Automotive Lift Institute.



Uniform Warning Labels and Placards for 2-Posts. Labels in Mandarin, French Canadian, and Spanish are also available.

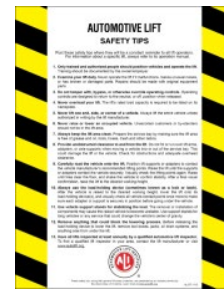

Safety Tips Card. Reminds your people of 13 key safety tips to follow daily.

Visit today and get the training and materials you need to work safely:
www.autolift.org/ali-store/.

BendPak[®]

30440 Agoura Road
Agoura Hills, CA 91301 USA
[bendpak.com](https://www.bendpak.com)