

Full-Rise Scissor Lift

Installation and Operation Manual

Manual P/N 5900010 — Manual Revision B3 — September 2023

Model:

- SP-7XE
- SP-7XEF

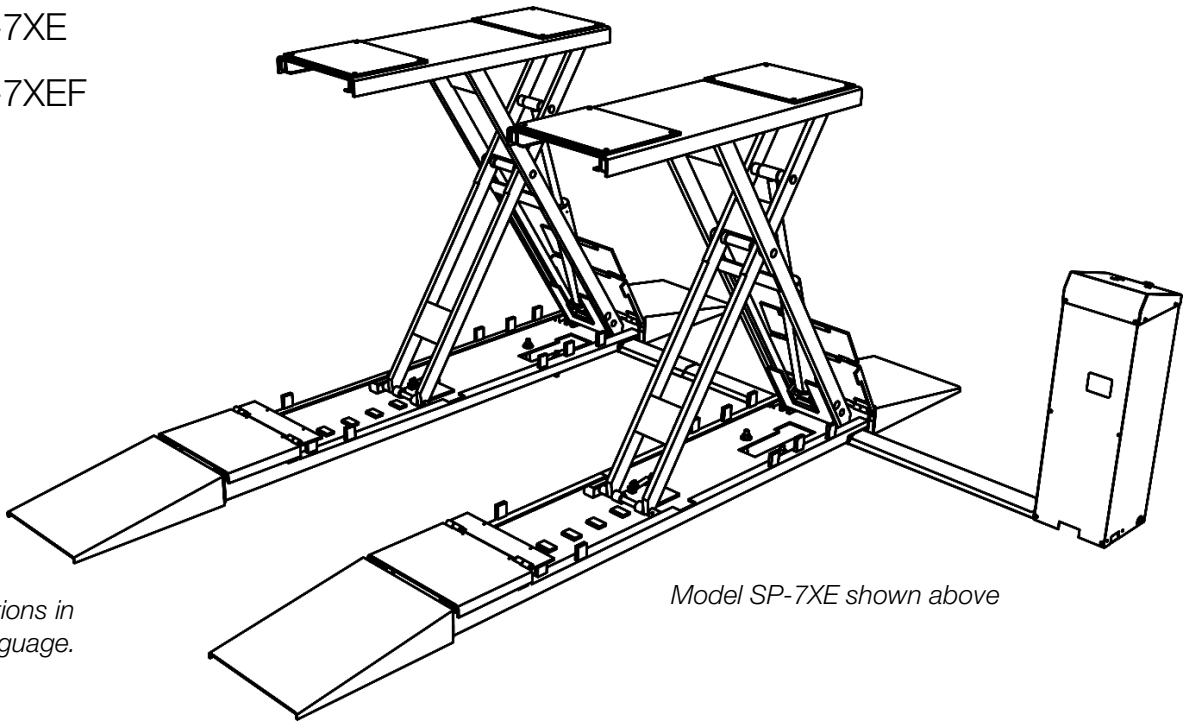

*Original Instructions in
the English Language.*

Model SP-7XE shown above

Designed and engineered by BendPak Inc. in Southern California, USA. Made in China.

 **DANGER**

IMPORTANT Safety Instructions, save these instructions! Read the *entire contents* of this manual *before* using this product. Failure to follow the instructions and safety precautions in this manual can result in severe injury or death. Make sure all other operators also read this manual. Keep the manual near the product for future reference. *By proceeding with installation and operation, you agree that you fully understand the contents of this manual and assume full responsibility for product use.*

Manual. SP-7XE and SP-7XEF Full-Rise Scissor Lift, *Installation and Operation Manual*, Manual Part Number 5900010, Manual Revision B3, released September 2023.

Copyright. Copyright © 2023 by BendPak Inc. All rights reserved. You may make copies of this document if you agree that: you will give full attribution to BendPak Inc., you will not make changes to the content, you do not gain any rights to this content, and you will not use the copies for commercial purposes.

Trademarks. BendPak and the BendPak logo are registered trademarks of BendPak Inc. All other company, product, and service names are used for identification only. All trademarks and registered trademarks mentioned in this manual are the property of their respective owners.

Limitations. Every effort has been made to ensure complete and accurate instructions are included in this manual. However, product updates, revisions, and/or changes may have occurred since this manual was published. BendPak reserves the right to change any information in this manual without incurring any obligation for equipment previously or subsequently sold. BendPak is not responsible for typographical errors in this manual. Feel free to contact us at any time to receive the latest information about any product: bendpak.com.



SCAN FOR
DIGITAL PDF

Warranty. The BendPak warranty is more than a commitment to you: it is also a commitment to the value of your new product. Contact your nearest BendPak dealer or visit www.bendpak.com/support/warranty for full warranty details. Go to bendpak.com/support/register-your-product/ and fill out the online form to register your product (be sure to click **Submit**).

Safety. Your product was designed and manufactured with safety in mind. However, your safety also depends on proper training and thoughtful operation. Do not install, operate, maintain, or repair the unit without reading and understanding this manual and the labels on the unit; **do not use your Lift unless you can do so safely!**

Owner Responsibility. In order to maintain your product properly and to ensure operator safety, it is the responsibility of the product owner to read and follow these instructions:

- Follow all installation, operation, and maintenance instructions.
- Make sure product installation conforms to all applicable local, state, and federal codes, rules, and regulations, such as state and federal OSHA regulations and electrical codes.
- Read and follow all safety instructions. Keep them readily available for operators.
- Make sure all operators are properly trained, know how to safely operate the unit, and are properly supervised.
- Do not operate the product until you are certain all parts are in place and operating correctly.
- Carefully inspect the product on a regular basis and perform all maintenance as required.
- Service and maintain the unit only with approved replacement parts.
- Keep the manual with the product and make sure all labels are clean and visible.
- **BendPak** makes no promises, guarantees or assurances that our products meet any state, county, federal or international mandated permit, license, code, standard, certification, or any other mandate other than what is listed or shown on BendPak website(s), or any BendPak or Ranger online or published catalog. Not all BendPak Lift models meet the standards as prescribed by ANSI/ALI ALCTV-(current edition) or ANSI/UL 201. Consult www.autolift.org for a complete list of Lift models that meet ANSI/ALI ALCTV-(current edition) or ANSI/UL 201, or contact BendPak via contact@bendpak.com. **Buyer assumes full responsibility for any state, county, federal or international mandated permit, license, code, standard, certification, or any other mandate required related to the installation and/or operation of any BendPak product.** BendPak will not be responsible for any charges, fines, liens, or other levies imposed on the Buyer related to any special or regional structural, seismic or any other building code and/or codes such as the Uniform Building Code (UBC), International Building Code (IBC), or any other state, county, federal or international mandated permit, license, code, standard, certification, or other mandate, law, rule, regulation or directive by any other agency, government, administrations, or corporations whether state, county, federal, or international mandated.
- **Only use the Lift if it can be used safely!**

Unit Information. Enter the Model Number, Serial Number, and the Date of Manufacture from the label on your unit. This information is required for part or warranty issues.

Model: _____

Serial: _____

Date of Manufacture: _____

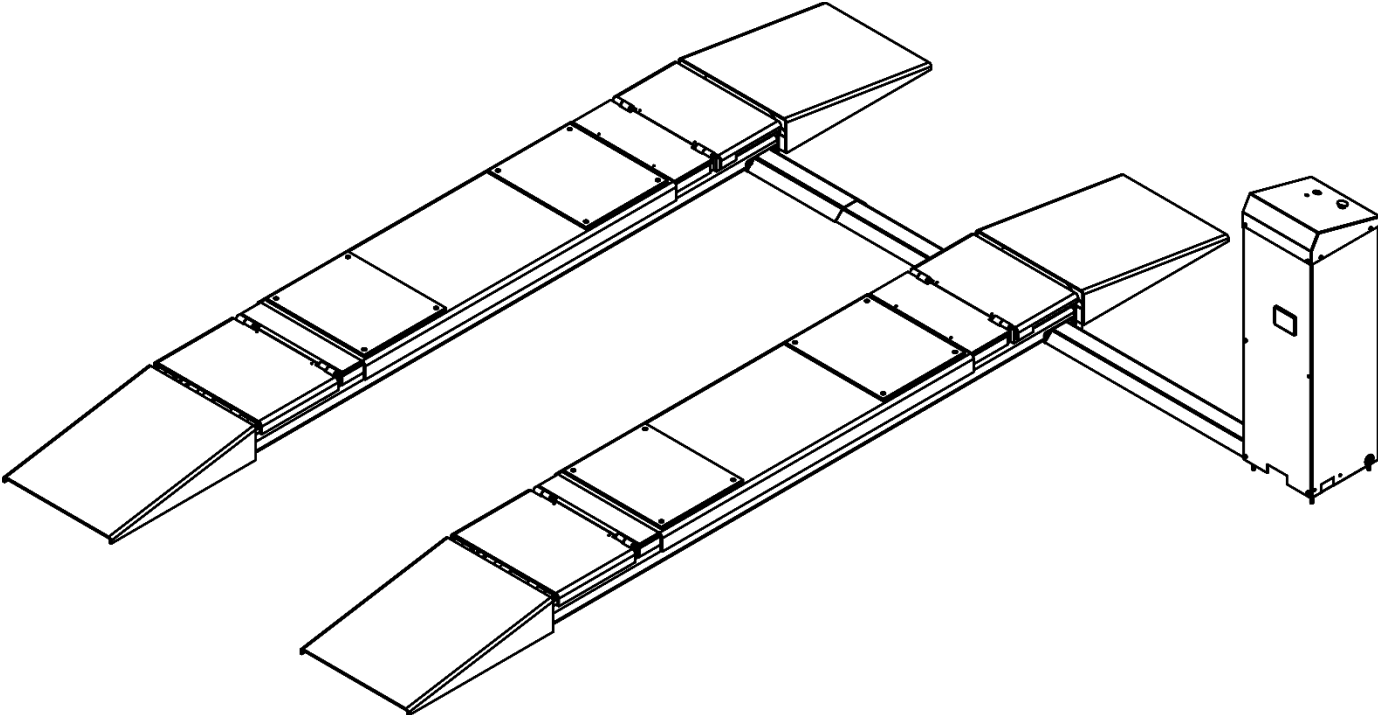

Model SP-7XE shown above.

Table of Contents

Introduction	4	Operation	50
Shipping Information	5	Maintenance	58
Safety Considerations	5	Troubleshooting	60
Components	8	Wiring Diagram	62
FAQs	10	Labels	64
Specifications	10	Parts Diagram	66
Installation Checklist	13	ALI Store	76
Installation	15	Maintenance Log	77

Introduction

This manual describes the SP-7XE and SP-7XEF, which are full-rise, frame-engaging lifts that feature an open-center design that provides full under-Vehicle access. They can be installed at ground level or recessed (SP-7XEF “flush mount”), frequently over a service pit. Flush mount models do not use Drive-up Ramps, but they do require a recessed surface. The installations for both units are similar. When the instructions differ, they will be identified by model number.

Both models raise Vehicles up to 7,000 lbs. / 3,175 kg.

More information about the full line of BendPak products is available at bendpak.com.

⚠ DANGER Be very careful when setting up, operating, maintaining, or repairing this equipment; failure to do so could result in property damage, product damage, injury, or (in very rare cases) death. Make sure only authorized personnel operate this equipment. An authorized technician must perform all repairs. Do not make modifications to the unit; this voids the warranty and increases the chances of injury or property damage. Make sure to read and follow the instructions on the labels on the unit.

This manual is mandatory reading for all users of SP-7XE/F Series Lifts, including anyone who installs, operates, maintains, or repairs them. Always keep this manual on or near the equipment.

Technical support and service is available from your dealer, on the Web at bendpak.com/support, by email at support@bendpak.com, or by phone at **(800) 253-2363**, option 7, then 4.

Online chat is also available at www.bendpak.com click the chat icon. 

Scan this QR Code for up-to-date information and videos on the SP-7XE/F Lift series.



Shipping Information

Your equipment was carefully checked before shipping. Nevertheless, you should thoroughly inspect the shipment **before** you sign to acknowledge that you received it.

When you sign the bill of lading, it tells the carrier that the items on the invoice were received in good condition. **Do not sign the bill of lading until after you have inspected the shipment.** If any of the items listed on the bill of lading are missing or damaged, do not accept the shipment until the carrier makes a notation on the bill of lading that lists the missing and/or damaged goods.

If you discover missing or damaged goods **after** you receive the shipment and have signed the bill of lading, notify the carrier at once and request the carrier to make an inspection. If the carrier will not make an inspection, prepare a signed statement to the effect that you have notified the carrier (on a specific date) and that the carrier has failed to comply with your request.

It is difficult to collect for loss or damage after you have given the carrier a signed bill of lading. If this happens to you, file a claim with the carrier promptly. Support your claim with copies of the bill of lading, freight bill, invoice, and photographs. Our willingness to assist in helping you process your claim does not make us responsible for collection of claims or replacement of lost or damaged materials.

Safety Considerations

Important Safety Instructions, save these instructions!

Read this manual carefully before using your new product. Do not set up or operate the product until you are familiar with all operating instructions and warnings. Do not allow anyone else to operate the product until they are also familiar with all operating instructions and warnings.

 **WARNING** **California Proposition 65.** This product can expose you to chemicals including styrene and vinyl chloride which are on the list of over 900 chemicals identified by the State of California to cause cancer, birth defects or other reproductive harm. For more information, visit www.P65Warnings.ca.gov.

Important Safety Instructions!

Read and understand all safety warning procedures before operating the Lift:





1. Read all instructions.
2. Care must be taken as burns can occur from touching hot parts.
3. Do not operate equipment with a damaged cord or if the equipment has been dropped or damaged – until qualified service personnel have examined it.
4. Do not let a cord hang over the edge of a table, bench, or counter or come in contact with hot manifolds or moving fan blades.
5. If an extension cord is necessary, a cord with a current rating equal to or more than that of the equipment should be used. Cords with a current rating less than the equipment may overheat. Care should be taken to arrange the cord so that it will not be tripped over or pulled.
6. Always unplug the equipment from the electrical outlet when not in use. Never use the cord to pull the plug from the outlet. Grasp the plug and pull to disconnect.

-
7. Let the equipment cool completely before putting it away. Loop cord loosely around equipment when storing.
 8. To reduce the risk of fire, do not operate in the vicinity of open containers of flammable liquids (gasoline).
 9. Adequate ventilation should be provided when working on operating internal combustion engines.
 10. Keep hair, loose clothing, fingers, and all parts of body away from moving parts.
 11. To reduce the risk of electric shock, do not use on wet surfaces or expose to rain.
 12. Use only as described in this manual. Use only BendPak recommended attachments and accessories.
 13. ALWAYS WEAR SAFETY GLASSES. Everyday eyeglasses only have impact resistant lenses, they are not safety glasses.
 14. To reduce the risk of injury, close supervision is necessary when this product is used around children.
 15. To reduce the risk of injury, **never** attempt to lift more than the rated capacity. Refer to loading instructions.
 16. The Lift uses electrical energy; if your organization has Lockout/Tagout policies, make sure to implement them after connecting the Lift to a power source.
 17. Refer to markings for proper load on electrical receptacles.
 18. Only operate your Lift between temperatures of +41°F to +104°F (+5°C to +40°C).
 19. The Lift should **only** be operated by authorized personnel. Keep children and untrained personnel away from the Lift.
 20. Do not make any modifications to the Lift; this voids the warranty and increases the chances of injury or property damage.
 21. Do not use the Lift while tired or under the influence of drugs, alcohol, or medication.
 22. Consider the work environment. Keep the work area clean. Cluttered work areas invite injuries. Keep areas well lit.
 23. **Always** make sure both Lift platforms are secured on their Safety Locks before attempting to work on or near a Vehicle.
 24. Make a thorough inspection of the product at least once a year. Replace any damaged or severely worn parts, decals, or warning labels. Replace worn or damaged parts with BendPak or BendPak approved parts and assemblies only.
 25. BendPak recommends referring to the ANSI/ALI ALIS Standard *Safety Requirements for Installation and Service* for more information about safely installing, using, and servicing your Lift.
 26. The SP-7XE and SP-7XEF are full-rise, frame-engaging, Scissor Lifts for servicing Vehicles. **Use it only for its intended purpose.** Improper use of this Lift could cause severe injury or death.
 27. You **must** wear OSHA-approved (publication 3151) personal protective equipment at all times when installing, using, maintaining, or repairing the Lift. Leather gloves, steel-toed work boots, eye protection, back belts, and hearing protection are **mandatory**.
 28. Keep loads balanced on the Lift Platforms. Clear the area immediately if a Vehicle is in danger of falling off the Lift.
 29. Do not make any modifications to the Lift. Modifications void the warranty and increases the chances of injury or property damage. Do not modify any safety-related features in any way.

-
30. Make sure all operators read and understand this Installation and Operation Manual. Keep the manual near the Lift at all times.
 31. While handling a Hydraulic Cylinder or a Hydraulic Hose, **always** wear gloves. In rare cases, a needle-like stream of hydraulic fluid (even at low pressure) can penetrate fingers, hands, or arms; such a puncture can feel like a bite, electric shock, or a prick. While it may seem like a minor issue, any amount of Hydraulic Fluid injected into the human body is a serious issue. Anyone suffering such a puncture wound should be **immediately** taken to a hospital emergency room to determine the extent of the injury. Explain the circumstances of the injury to the attending physician, including what kind of Hydraulic Fluid was involved. Do not assume a puncture wound that could have been caused by Hydraulic Fluid is a minor issue; it could be life threatening.
 32. Make an inspection of the Lift **before** using it. Check for damaged, worn, or missing parts. Do not use it if you find any of these issues. Instead, take it out of service, then contact an authorized repair facility, your dealer, or BendPak at **(877) 432-6627** or support@BendPak.com.
 33. BendPak recommends referring to the ANSI/ALI ALIS Standard *Safety Requirements for Installation and Service* for more information about safely installing, using, and servicing your Lift.

Symbols

Following are the symbols used in this manual:

-  **DANGER** Calls attention to an immediate hazard that **will** result in injury or death.
-  **WARNING** Calls attention to a hazard or unsafe practice that **could** result in injury or death.
-  **CAUTION** Calls attention to a hazard or unsafe practice that could result in minor personal injury, product, or property damage.
- NOTICE** Calls attention to a situation that, if not avoided, could result in product or property damage.
-  **Tip** Calls attention to information that can help you use your product better.

Liability Information

BendPak Inc. assumes **no** liability for damages resulting from:

- Use of the product for purposes other than those described in this manual.
- Modifications to the equipment without prior written permission from BendPak Inc.
- Injury or death caused by modifying, disabling, overriding, or removing safety features.
- Damage to the equipment from external influences.
- Incorrect operation of the equipment.

Components

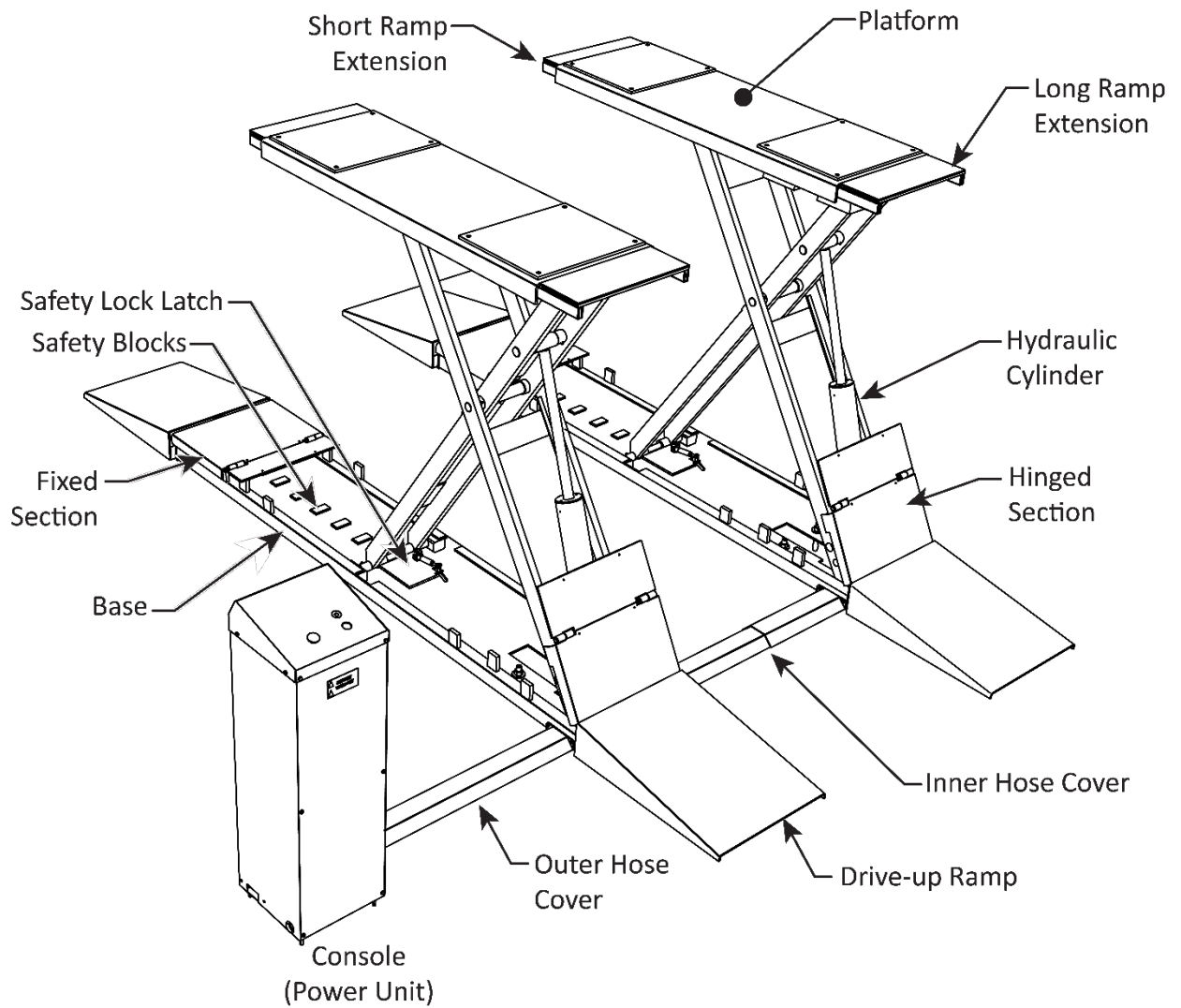

SP-7XE Model shown. SP-7EXF does not include Drive-up Ramps or Hose Covers.

SP-7XE Series Lift components include:

- **Console** — Hosts the controls for the Lift (on top) and the Power Unit (inside). The connections for the Hydraulic Hoses and the Air Lines connect to the Power Unit inside the Console.
- **Power Unit** — Provides Hydraulic pressure to the Hydraulic Cylinders, which are used to raise the Platforms. Housed inside the Console. Connects to an external power source and to the Lift Controls.
- **Hose Covers** — Covers the Air and Hydraulic Hoses.
- **Drive-up Ramps** — Used to drive on or off the Platforms. Not included with the SP-7XEF.
- **Hinged Section** — Hinges up when the Platforms are raised.
- **Fixed Section** — On the opposite end from the Hinged Section. Can be raised for installation, but otherwise stays in place. Does not hinge up when the Platforms are raised.
- **Platforms** — Flat steel plates that raise and lower. The Platforms, or the Lift Pads on the Platforms, contact the undercarriage of the Vehicle to raise and lower it.
- **Ramp Extensions** — Attaches to the Platforms, used for supporting Vehicles with longer wheelbases.
- **Bases** — The bottoms of the Lift. They hold the Scissor Legs, Hydraulic Cylinders, Air Cylinders, Safety Locks, and the bolt holes for the Anchor Bolts. The Lift is bolted into place using the Anchor Bolt holes in each Base.
- **Frames** — Combination of a Platform and a Base.
- **Scissor Legs** — The mechanism of the Lift that raises and lowers, powered by the Hydraulic Cylinders.
- **Hydraulic Cylinders** — Push the Platforms up to raise a Vehicle, move down to lower a Vehicle.
- **Safety Locks** — Hold the Platforms in place and consist of a latching mechanism and welded blocks on each Lift Platform assembly. The SP-7XE/F has eight Safety Lock positions, which allow selection of the ideal Platform height for your use.
- **Air Cylinders** — Part of the Safety Lock Mechanism uses pressurized air to move the Safety Lock Mechanism off the Safety Lock to lower the Lift. It is the user's responsibility to provide an air pressure supply (minimum 50 psi / 10 CFM, regulated to a *maximum* of 125 psi).
- **Lift Pads** — Rubber Pads that contact the Lifting Points on the Vehicle being raised. The Lift is supplied with four Lift Pads.

Frequently Asked Questions

Question: How much weight can the SP-7XE/F raise?

Answer: The SP-7XE/F can lift Vehicles up to 7,000 pounds (3,175 kg).

Q: The SP-7XEF is described as “flush mount”, what does that mean?

A: It means the Bases of the SP-7XEF are installed **below** the surface of the Concrete, in Concrete Cutouts. The tops of the Platforms are flush with the Concrete floor, so Vehicles just drive straight on—no Drive-up Ramps are required. Sufficient Concrete depth is required **under** the Concrete Cutout. See [Prepare the Concrete Cutouts: SP-7XEF only](#) for more details.

Q: The SP-7XE/F is called a “Full-Rise” Lift, what does that mean?

A: It means that the SP-7XE/F can raise a Vehicle almost six feet off the ground, which is higher than most other Scissor Lifts. Additionally, the SP-7XE/F incorporates eight Safety Lock positions, which means the Lift may be locked at the height most convenient for the work.

Q: Can the SP-7XE/F be installed outside?

A: No. The SP-7XE/F is approved for indoor installation and use only. **Outdoor installation is prohibited.**

Q: Can I put the Console on either side of the SP-7XE/F?

A: Yes. The Hydraulic Hoses that come with the SP-7XE/F are long enough to support the Console positioned up to 39.25 inches (999 mm) away from the Base on either side.

Q: What if I want to raise a Vehicle that is slightly over the weight capacity of the Lift?

A: *This is not an intended use of the product.* Do **not** attempt to raise a Vehicle that is heavier than the rated capacity of your Lift. If you do, you void your warranty, you could damage the Lift and/or the Vehicle you are raising, and you jeopardize the safety of people under or near the Lift.

Q: What do the Safety Locks do?

A: Safety Locks use gravity and intelligent engineering to hold the Platforms up once the Safety Locks are engaged. Even if the Lift loses power or the Hydraulic Hoses are cut, the Platforms stay where they are if they are engaged on a Safety Lock. **Only leave your Lift either fully lowered or engaged on a Safety Lock! Additionally, NEVER work under a vehicle if the Lift is not engaged on a Safety Lock!**

Q: Which end of the SP-7XE/F is the “front”?

A: There is no front or back. You can drive Vehicles onto and off the Lift in either direction.

Q: The SP-7XE/F is described as “frame-engaging”, what does that mean?

A: It means the Platforms (specifically the Rubber Blocks on the Platforms) contact the frame of the Vehicle to raise it. Put another way, the Vehicle is **not** raised by its wheels.

Q: The space between the Platforms is too wide for my small Vehicle. What can I do?

A: You can purchase the optional Lift Arm Kit. The Lift Arms extend into the space between the Platforms, providing additional options for smaller Vehicles.

Q: Is there a Lift Arm Attachment for the SP-7XE?

Y: See page 52 for more information on the optional Lift Arm Kit.

Specifications

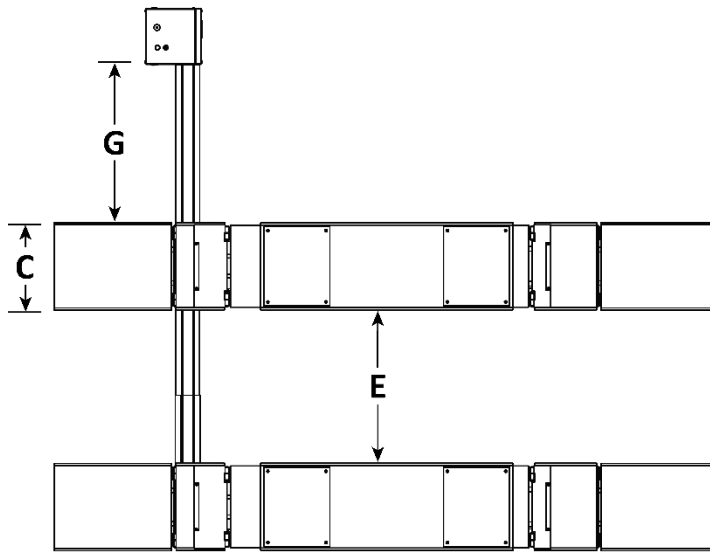

Top View

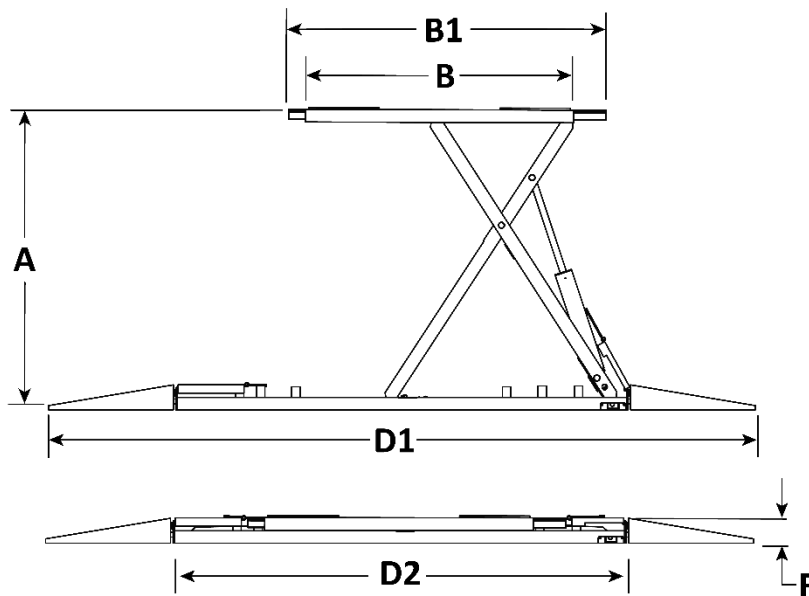

Side View

SP-7XE shown. The SP-7XE**F** does not have Ramps or Hose Covers.

Model	SP-7XE	SP-7XEF
Mounting Style	Surface mount	Flush mount
Lifting capacity	7,000 lbs. / 3,175 kg	
A Maximum height raised (no blocks)	70.5 in. / 1,790 mm	
B Individual Platform length	62.5 in. / 1,590 mm	
B1 Extended Platform length	74 in. / 1,880 mm	
C Individual Platform width	21.75 in. / 550 mm	
D Total length	D1: 165 in. / 4,190 mm (includes Drive-up Ramps)	D2: 106 in. / 2,692 mm (no Drive-up Ramps)
E Distance between Platforms	38 – 44 in. / 968 – 1,114 mm	38 in. / 968 mm
F Lowered height	6.5 in. / 161 mm	N/A (Top of Platform to be flush with floor)
G Max distance to Console*	Up to 39.25 in. / 999 mm	
Safety Lock Positions	8	
Lifting time	≈45 seconds	
Motor**	220 VAC, 50/60 Hz, 1 Ph	
Operating Pressure at Max. Load	3,060 psi	

* With the supplied Hydraulic Hoses.

**Special voltages available upon request.

Specifications subject to change without notice.

Installation Checklist **SP-7XE**

Following are the steps needed to install a SP-7XE Lift. Perform them in the order shown.

- 1. Review the installation Safety Rules.
- 2. Plan for Electrical Work.
- 3. Make sure you have the necessary Tools.
- 4. Select the Installation Site.
- 5. Create a Floor Plan.
- 6. Verify there is adequate clearance on all sides of the Lift.
- 8. Create Chalk Line Guides.
- 9. Move both bases into the chalk lines and Lift both Platforms onto the same safety lock.
- 10. Evaluate for out of level conditions and calculate shim requirements
- 11. Drill then install Anchors and Shim as required to bring the Platforms into a level condition.
- 12. Torque all anchors to secure, then tuckpoint cement between the base and the concrete floor to fill voids under the Base and lock the Shims into place.
- 13. Assemble the Console and attach the Power Unit.
- 14. Anchor the Console.
- 15. Learn about Hydraulic Fluid Contamination.
- 16. Learn about Thread Sealants.
- 17. Connect the Hydraulic Hoses.
- 18. Learn About Compression Fittings and Tubing.
- 19. Connect the Air Lines.
- 20. Install the Hose Covers.
- 21. Connect the Power Unit (**Electrician required**).
- 22. Install a Power Disconnect Switch and Thermal Disconnect Switch (**Electrician required**).
- 23. Perform an Operational Test.
- 24. Add the Ramp Extensions.
- 25. Add the Drive-up Ramps.
- 26. Review the Final Checklist.
- 27. Leave the Manual for the owner/operator.

Installation Checklist **SP-7XEF**

Following are the steps needed to install a **SP-7XEF** Lift. Perform them in the order shown.

Important: Consult a Concrete Specialist about creating the Concrete Cutouts **well before beginning the installation.**

- 1. Review the installation Safety Rules.
- 2. Plan for Electrical Work.
- 3. Make sure you have the necessary Tools.
- 4. Select the Installation Site.
- 5. Create a Floor Plan.
- 6. Verify there is adequate clearance on all sides of the Lift installation area.
- 7. Create the Concrete Cutouts.
- 8. Move both bases into the concrete cutouts and Lift both Platforms off their Bases onto the same safety lock.
- 9. Evaluate for out of level conditions and calculate shim requirements
- 10. Anchor the Bases and shim as required to bring the platforms into a level condition.
- 11. Assemble the Console and attach the Power Unit.
- 12. Anchor the Console.
- 13. Learn about Hydraulic Fluid Contamination.
- 14. Learn about Thread Sealants.
- 15. Route, then connect the Hydraulic Hoses.
- 17. Learn About Compression Fittings and Tubing.
- 18. Route then connect the Air Lines.
- 20. Connect the Power Unit (**Electrician required**).
- 21. Install a Power Disconnect Switch and Thermal Disconnect Switch (**Electrician required**).
- 22. Perform an Operational Test.
- 23. Add the Ramp Extensions.
- 25. Review the Final Checklist.
- 26. Leave the Manual for the owner/operator.

Installation

This section describes how to install your SP-7XE/F. Perform the steps in the order listed.

⚠ WARNING **Use only the factory-supplied parts that came with your lift.** If you use parts from a different source, you void your warranty and compromise the safety of everyone who installs or uses the Lift. If you are missing parts, visit bendpak.com/support or call **(800) 253-2363**, option 7, then 5.

Your Lift is supplied with installation instructions and concrete fasteners that meet the criteria set by the current version of the American National Standard “Automotive Lifts – Safety Requirements for Construction, Testing, and Validation.”

Lift buyers are responsible for regional, structural, and/or seismic anchoring requirements specified by any other agencies or codes, such as the Uniform Building Code or International Building Code.

Safety Rules

When installing the Lift, your safety depends on proper training and thoughtful operation.

⚠ WARNING Do not install this equipment unless you have automotive Lift installation training. Always use proper tools, such as a Forklift or Shop Crane, to move heavy components. Do not install this equipment without reading and understanding this manual and the safety labels on the unit.

BendPak recommends referring to the ANSI/ALI ALIS Standard *Safety Requirements for Installation and Service* for more information about safely installing, using, and servicing your Lift.

Only fully trained personnel should be involved in installing this equipment. **Always pay attention.** Use appropriate tools and equipment. Stay clear of moving parts.

⚠ WARNING You must always wear protective equipment during the installation: leather gloves, steel-toed work boots, eye protection, back belts, and hearing protection.

Electrical Work

You will need to have a licensed, certified Electrician available at some point during the installation.

⚠ DANGER All wiring **must** be performed by a licensed Electrician in accordance with all applicable national, state, and local electrical codes.

The Electrician needs to:

1. **Connect the Power Unit to a 220 VAC power source.** This is generally done near the end of the installation. Note that installing the Power Unit and connecting the Power Unit are separate procedures; while anyone can install the Power Unit, the Electrician **must** connect the Power Unit to Power. The Electrician must provide a Power Cord with an appropriate plug.
2. **Install a Power Disconnect Switch.** A Power Disconnect Switch gives you a way to shut down the Lift in the event of an electrical circuit fault or emergency. Refer to [Install a Power Disconnect Switch](#) for more information.

-
3. **Install a Thermal Disconnect Switch.** A Thermal Disconnect Switch automatically shuts down the Lift in the event of an overload or an overheated motor. Refer to [Install a Thermal Disconnect Switch](#) for more information.

Tools

You may need some or all of the following tools:

- Rotary Hammer Drill or similar
- 3/4", 3/8", 1 1/4" Masonry Drill Bits
- Hammer
- Open-end Wrench set: 1/2", 15/16" – 1 1/8"
- Socket and ratchet set, 1 1/8"
- Medium adjustable wrench
- White lithium grease
- Crowbar
- Chalk line
- Medium flat screwdriver
- Tape measure (25-foot recommended)
- Forklift or Shop Crane
- Quikrete® Fastset® or equal structural grout

Select a Site

Keep the following in mind when selecting a site for your Lift:

 **DANGER** **Risk of explosion.** This equipment has internal arcing or sparking parts which should not be exposed to flammable vapors.

- **Clearance.** You must have adequate space on all sides, plus enough space above for the Vehicles you will be raising. See [Clearance Around the Lift](#) for more information.
- **No overhead obstructions.** The site must be free of overhead obstructions.
- **Operator.** The operator at the Console **must** have a full, unobstructed view of the SP-7XE.
- **Console.** The Console must be positioned near the Lift; the Hydraulic Hoses that are supplied with the SP-7XE models support up to 40 inches between the Lift and the Console.
- **Concrete specifications. BendPak strongly recommends consulting a Concrete Specialist early in your planning process for Lift installations. The recommendations presented in this manual are generic in nature and cannot cover all situations. A Concrete Specialist will adjust these recommendations to account for national, state, and local building codes as well as local weather conditions, soil composition, base preparation, load bearing, seismic requirements and any other structural concerns that may arise.**

Evaluate the concrete at the installation location, Do **not** install the Lift on cracked or defective concrete. It is critical to determine the thickness and compression strength of the existing Concrete floor. Concrete floors must have a compression strength of at least 3,000 psi to support the Lift. A minimum of 4.25 in. / 108 mm of concrete is required **under** the Lift Frames. Drill and test a core sample to determine if the Concrete in your location meets the minimum requirements specified here. Concrete must be cured for at least 28 days (if newly poured). Verify the floor is defect-free, dry, and level. Note that for Flush-Mount models SP-7XEF require a greater depth of concrete; there must be 4.25 inches of Concrete **below the bottom of the Concrete Cutout**. If you intend to run the Hydraulic and Air Lines to some location farther than 40 inches from the Lift,

consult with your Concrete Specialist to determine the size, depth, and location of the conduits needed for the Hydraulic and Air Lines. No Lift Anchor Bolt should be closer than 6-inches to any inconsistency in the concrete (e.g., expansion joints or cracks).

⚠ WARNING Do not install the Lift on a surface with a slope greater than 3°. A slope in excess of 3° could lead to an unstable vehicle resulting falling and resulting in property damage, personal injury, or death.

- **SP-7XEF installations.** BendPak *strongly* recommends early consultation with a Concrete Specialist to plan and create the Concrete Cutouts for your Flush-Mount Lift.
- **Power.** The Lift requires a 208 to 240 VAC, single phase power source available near the Console. If electrical power is to be run to the Console under New Pour Concrete, consult with a licensed Electrician to ensure the correct location, depth, size, and type of electrical conduit are installed according to national and local electrical codes.
- **Operating temperature.** The Lift is designed to be used between temperatures of 41° to 104°F (5° to 40°C).
- **Outdoor installation.** The SP-7XE/XEF Lifts are designed and approved for indoor installation and use only. **Outdoor installation is prohibited.**
- **Second floor installations.** Do not install the Lift on a second floor or elevated floor without first consulting the building architect and receiving approval.
- **Set up Chalk Line Guides.** Create Chalk Line Guides or tape lines to verify the Lift will function in your chosen location. BendPak strongly suggests a dry run using a vehicle to verify the Lift approach and exit will be safe and efficient in this location.

Create a Floor Plan

Make sure to plan out, *in advance*, where the Lift and Console will be installed:

- **Clearance.** Verify there is adequate clearance on all sides and above the Lift.
- **Console.** The Console must be near the Lift; it can be installed on either side of the Lift, but only on the Cylinder-end of the Platforms. The supplied Hydraulic Hoses can support up to 40 inches between the Lift and the Console.
- **Operator.** The Operator at the Console **must** have a full, unobstructed view of the Lift while raising and lowering vehicles.
- **Power.** The Console **must** be positioned near an appropriate power source.
- **Create Chalk Lines.** Create Chalk Lines or tape lines for the Lift to verify it is properly aligned in the location.

Clearances around and above the Lift

For safety purposes, a reasonable amount of clear space around and above the Lift is **required**, as depicted in the figure below.

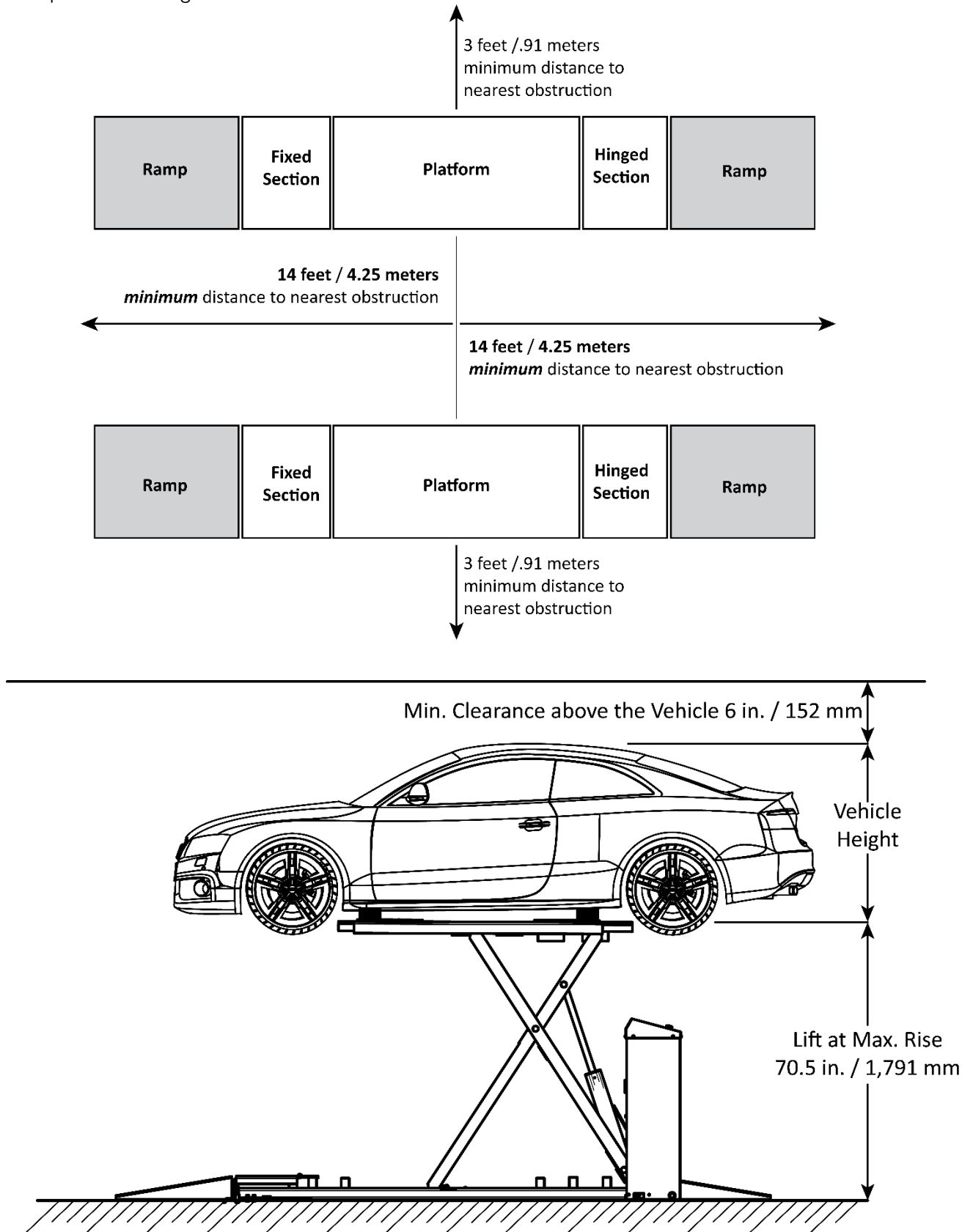

New Concrete Slab Requirements

If your existing Concrete does not meet the requirements previously listed, then a New Concrete Slab may be required.

⚠ CAUTION BendPak strongly recommends working with a Concrete Specialist to plan and create Concrete Cutouts and/or new Slabs for the **SP-7XE and SP-7XEF** model.

All properties of the New Concrete Slab are **mandatory** and **must** conform to the following requirements:

- New Concrete Slabs **must** have a *minimum* compression strength of 4,000 PSI, cured for at least 28 days, and a surface slope not exceeding 3°.
- New Concrete Slabs **must** have a *minimum* thickness of 4.25 in. **SP-7XE** (11 in. **SP-7XEF**).
- New Concrete Slabs **must** be fully surrounded by and flush with the existing Concrete Floor.
- New Concrete Slabs **must** be “Keyed-in” around the perimeter **or** may be “Tied-in.”
- Locate reinforcing bars away from any Anchor positions or at an elevation that allows you to avoid drilling into reinforcing steel while installing the Expansion Anchors for the Lift.
- Certified strength documentation for New Pours should be obtained from the firm who supplies the Concrete Mixture at the time of the Pour.
- **Never** install the Lift over an expansion joint.
- **Never** install the Lift on hand-mixed concrete.
- **Never** install the Lift on a secondary floor level without written authorization from the building Architect and prior approval from BendPak.
- **Never** drill or cut into a post-tensioned slab. Contact qualified personnel prior to drilling or cutting to check your floor for the possibility of it being a post-tensioned slab.

Key-In / Tie-In Details

New Concrete Pour must be connected to the existing concrete surrounding it. Two methods are recommended here, Key-in and Tie in. **There is no need to complete both methods, choose one or the other.**

- **Key-in.** This key-in method undercuts the existing concrete by **6 in. / 152 mm** around the perimeter of the New Pour, effectively locking the New Pour into the existing concrete.
- **Tie-in.** This tie-in method uses Anchor Dowels and the New Pour. Anchor Dowels are to be **#4 Rebar x 18 in. / 457 mm long**. These Anchor Dowels are then embedded **3 in. / 76 mm** minimum into the existing Concrete and spaced **18 in. / 457 mm** apart around the perimeter of the New Pour.

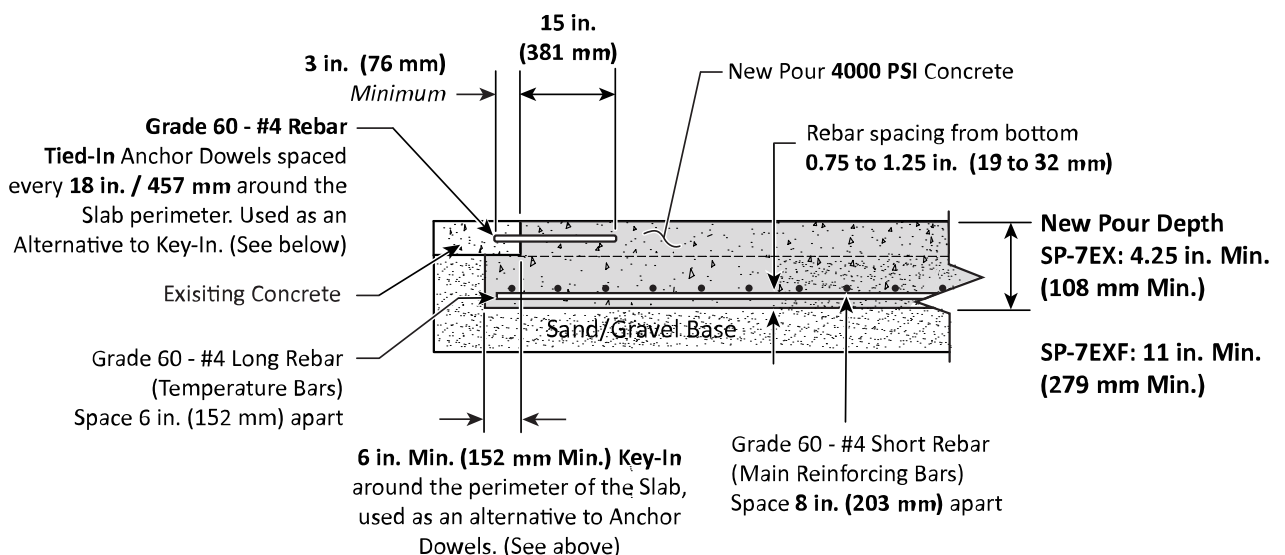

Prepare the Concrete Cutouts: SP-7XEF Only

Important: BendPak *strongly* recommends working with a Concrete Specialist to plan and create the Concrete Cutouts for your Flush-Mount Lift.

It is important to understand the following **before** creating the Concrete Cutouts for your Lift:

- **Planning ahead. Before** creating Concrete Cutouts for the Lift, decide where the Lift is to be installed, which side of the Lift will the Console be installed on, how far away from the Lift will the Console be, and how far apart the two Bases will be. These decisions need to be incorporated into the plan created with your Concrete Specialist.
- **Concrete Cutouts.** The Lift Bases of a Flush-Mount Lift are installed in a recessed section of the floor, called a *Concrete Cutout*. This cutout may be made in the existing concrete if it meets the thickness, compression, and condition requirements listed in this section. If not, then a reinforced New Pour is required.
- **Depth of the Concrete Cutouts.** Concrete Cutouts must be a specific depth below floor level so that when the Lift is put down into the Concrete Cutout, the top of the Lift's Platforms are flush with the existing floor.
- **Concrete Curing Time.** New Concrete Pour must cure for a minimum of 28 days before they are strong enough to support Anchor Bolts.
- **Floor Material.** Concrete Cutouts and New Pour must be surrounded by and created in a **Concrete** floor; no other surface (asphalt, dirt, anything else) is acceptable.
- **Cutout Size.** Concrete Cutouts need to be slightly larger than the Bases. The values listed at the end of this section add **0.5 inch / 2.75 mm** on all four sides to the Length and Width of the Bases.

- **Concrete Depth.** The Concrete depth **below the bottom** of the Concrete Cutouts must be deep enough for the Anchor Bolts; a **minimum** of 4.25 in. / 108 mm is required.
- **Air and Hydraulic Lines:** Your plans for the Concrete Cutouts must account for how these Air and Hydraulic Lines will be routed to the Console.

PVC Conduit with a 2.5-inch minimum diameter is commonly used to route the Hydraulic and Air Lines between the two Frame Assemblies and the Console. If you plan to cut in existing concrete, then plan for cutting channels between the Frame Assemblies and the Console to fit the PVC Conduit and then cover with Concrete.

Both Bases include rectangular openings for routing the Hydraulic and Air Lines already created; there are two per Base, both on the Cylinder end. These opening are available they are not required to be used.

- **Lift Location.** Use care when selecting a location for a Flush-Mount Lift. Once you create your Concrete Cutouts, the Lift location is permanent. Choose a location that allows a straight approach to the Lift, without obstructions, and allows access to air and the power source.
- **Console Location.** The Console can go on either side of the Lift, but at the Cylinder end of the Frame Assemblies. The supplied Hydraulic Hoses support up to 40 inches / 1,016 mm away from the closest Frame Assembly. You can mount the Console farther away, but this will require custom-length Hydraulic Hoses, longer Air Lines and more Hydraulic Fluid. Remember to create a path through the Concrete towards the Console for routing the Hydraulic and Air Lines.
- **Distance between Bases.** The Bases can be a variable distance apart, allowing you to pick the best width for the Vehicles you will be lifting.
- **Diagram.** Use the dimensions shown in the following diagram as a guide for your Concrete Cutouts.

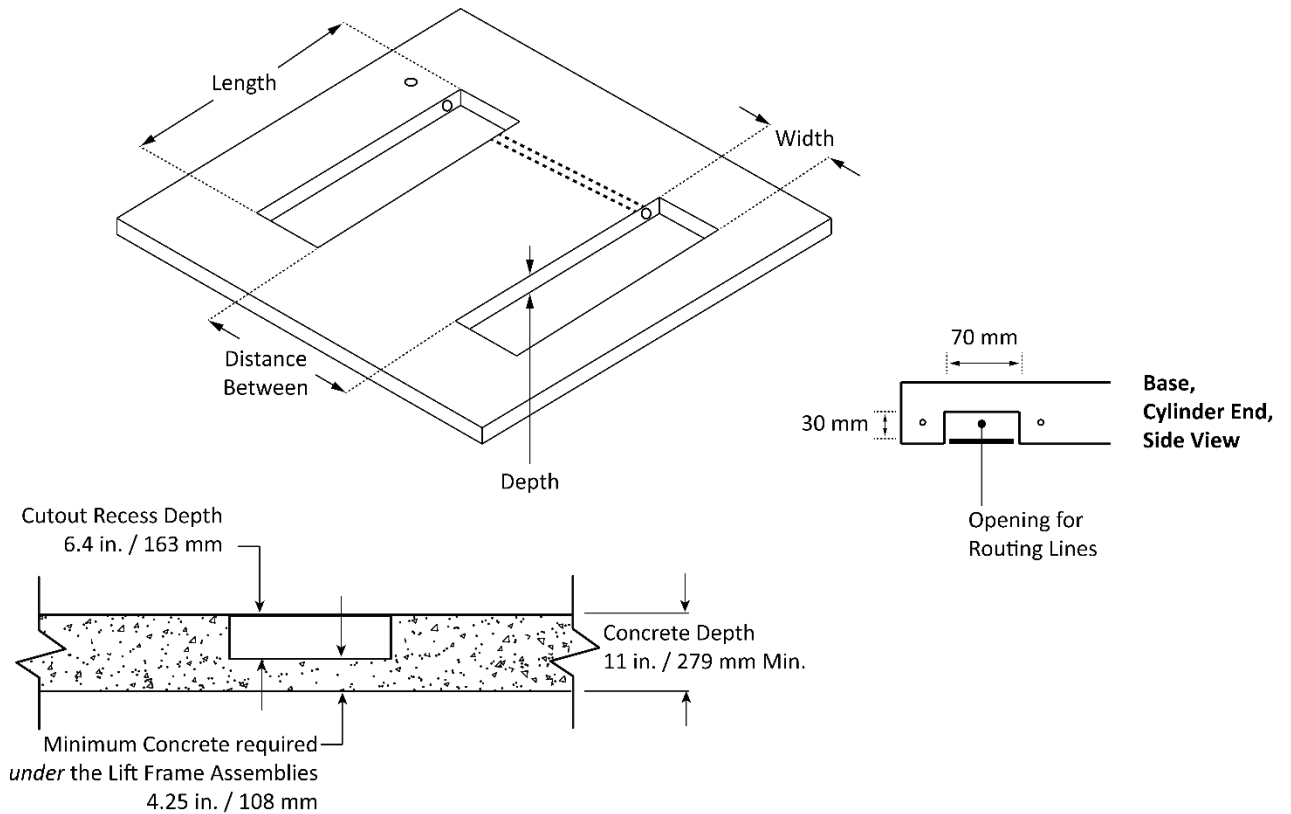

*Not all components shown. There must be 4.25 inches of Concrete **below** the bottom of the Concrete Cutouts. In this drawing, the Console would be on the left.*

The Flush-Mount Lift settings for the **SP-7XEF** are:

- **Length.** The Length of each SP-7XEF Frame Base is 106 inches / 2,692 mm; make the cutout 1 in. / 25 mm longer to get **≈107 inches / 2,718 mm**.
- **Width.** The Width of each SP-7XEF Frame Base is 22 inches / 559 mm; make the cutout 1 in. / 25 mm wider to get **≈23 inches / 584 mm**.
- **Depth.** The Lowered height of each SP-7XEF Frame is **6.4 inches / 163 mm**. Do **not** add an extra inch to this value.
- **Distance Between.** The two SP-7XEF Bases can be from **38 to 44 inches / 965 to 1,118 mm** apart. You do **not** add an extra inch to this value.
- **Important:** If you are installing the SP-7XEF over a pit, **do not** set the **Distance Between** to the width of the pit if the width of the pit is less than 38 inches or more than 44 inches. The two Bases must be from 38 to 44 inches apart, even if installed over a Service Pit.
- **Distance to the Console.** The supplied Hydraulic Hoses allow the Console to be up to **40 inches / 1016 mm** from the nearest Base. Do **not** add an extra inch to this value.

⚠ CAUTION

If you create your Concrete Cutouts and then change your mind about the Distance Between or find out you made a mistake with one of the dimensions, it is very difficult to fix. **BendPak strongly recommends checking your plans several times before cutting and pouring your Concrete Cutouts.**

Create Chalk Line Guides SP-7XE Only

Create Chalk Line Guides to make sure the Frames are parallel and in the desired location. The following drawing shows the Alignment Chalk Lines to create for your Lift.

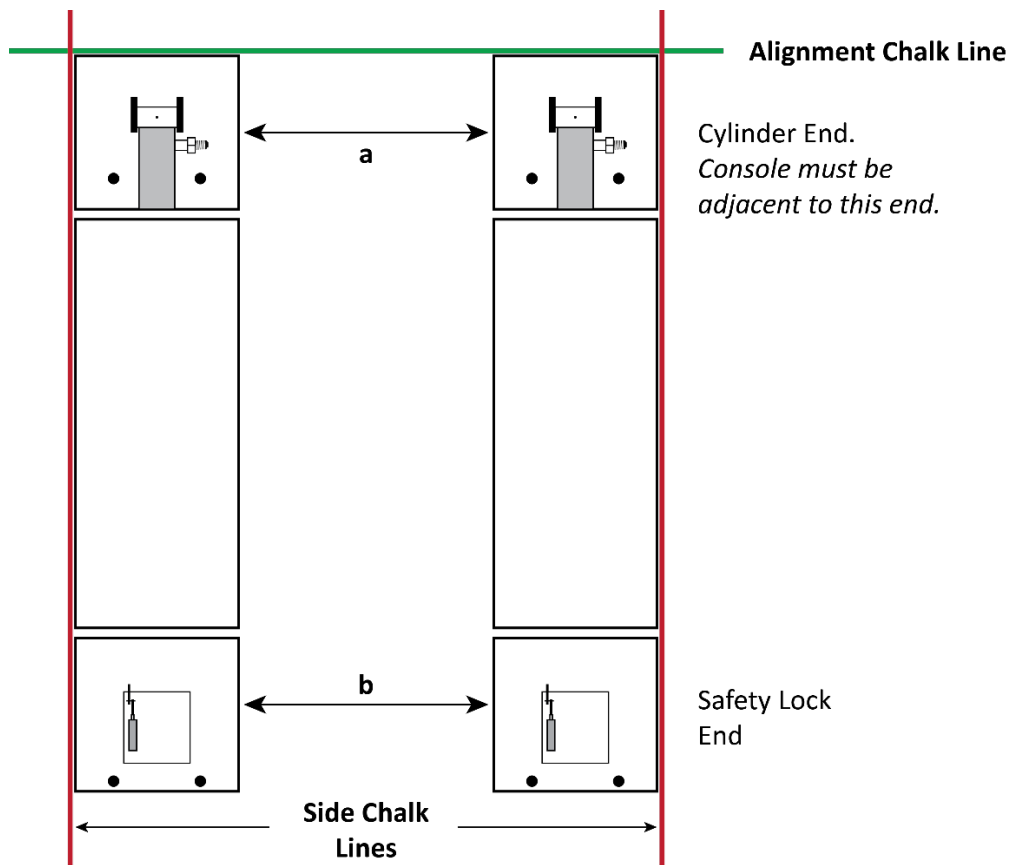

To add Chalk Line Guides:

1. Decide where the Lift is to be located.
2. Refer to the figure above. Create an Alignment Chalk Line for one end of the **SP-7XE**.
Make the Alignment Chalk Line **longer** than the **Overall Width** and the space between them.
3. Create two additional Side Chalk Lines: they need to be perpendicular to the Alignment Chalk Line, parallel to each other, and the correct distance apart (38 in. to 44 in. / 965 mm to 1,118 mm plus the width of the two Frames, 44 in. / 1,118 mm).
4. Move each Frame into position, into the corners created by the four Chalk Lines.

NOTICE The Hydraulic Cylinder ends of both Frames must be positioned adjacent to the Console.

5. Measure the distance between the two Frames at points **a** and **b**; they need to be the same distance apart at both ends.

Important: If **a** and **b** are not the same, adjust the position of the Frames to make them the same; **a** and **b must** be the same distance apart and parallel to each other.

6. When the Frames are in the correct location, move to the next section.

Lift the Platforms Off the Bases SP-7XE/XEF

Raise the Platforms off the Bases to access the anchor points. **When you raise the Lift Platforms make sure to leave it engaged on a Safety Lock.**

NOTICE

BendPak strongly recommends raising the Platforms to the Top Safety Lock, to provide enough room under the Platform to install the Anchor Bolts and make the Hydraulic and pneumatic connections.

⚠️ WARNING

Do not place any part of your body under the Platform while it is being raised. Use a wood 2 x 4 or other suitable device to hold the Base in position until the Platform is secure on a Safety Lock.

⚠️ WARNING

You must always wear OSHA-approved (Publication 3151) Personal Protective Equipment when installing the Lift: leather gloves, steel-toed boots, eye protection, back belts, and hearing protection are **mandatory**.

To lift the Platforms off the Bases:

1. Use Crowbars to lift the Platforms off their Bases, then carefully, slip a rope, chain, or industrial strap (sling) under each end of the Platform.



Tip Once the Platform and Base are separated by more than .5 in. (≈ 13 mm), you may use industrial slings (straps) around each end to continue raising the Platform off the Base.

⚠️ WARNING

Beware of all pinch points and crush hazards. Always keep hands and feet clear.

⚠️ WARNING

BendPak strongly recommends using **at least three people** to lift the Platforms off their Bases: one person on each end to hold down the Base and one person to operate the Forklift or Shop Crane to raise the Platform. **Use care when raising the Platforms off their Bases; they are heavy and difficult to hold.**



⚠️ WARNING

You **must** always wear OSHA-approved (publication 3151) Personal Protective Equipment when installing the Lift: leather gloves, steel-toed boots, eye protection, back belts, and hearing protection are **mandatory**.

2. Using a Forklift or Shop Crane, carefully raise the Platform off its Base.
3. When the Platform is raised to the Top Safety Lock, lower it back down and leave the platform on that **Top Safety Lock**.

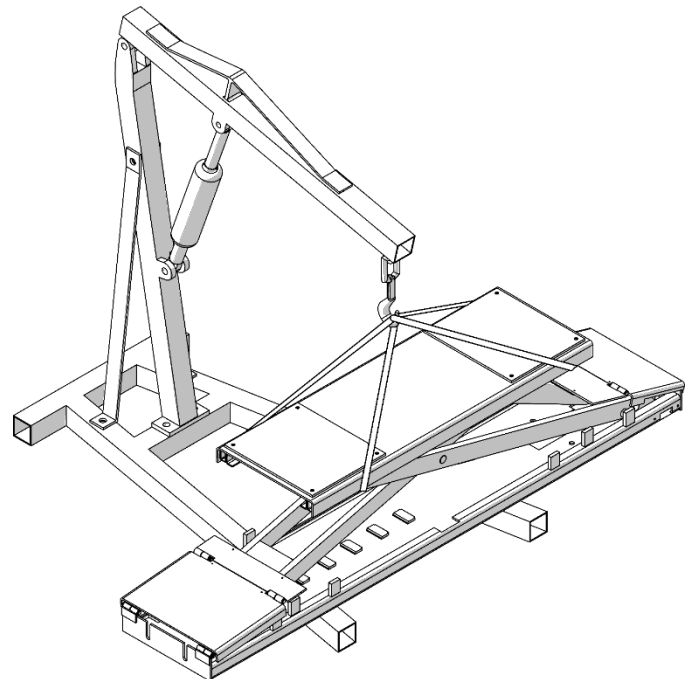

⚠ WARNING Never work under a platform or vehicle unless the platform is safely engaged on a safety Lock.

⚠ WARNING The Lifting Frame Assemblies are heavy. Do not lift the Platforms without assistance.

4. When the Platform is above the top Safety Lock, lower it back down onto the top Safety Lock. Leave the platform on that **Top Safety Lock**.
5. Repeat the same procedure on the second Platform.
6. Verify the bases are within the chalk line guides before proceeding.

Anchor the Bases SP-7XE/XEF

Each Base provides four holes for anchoring. Anchor Bolt Assembly Part Number 5530456 are provided with the Lift.

⚠ CAUTION Once the Anchor Bolts are torqued into position, they are not easily removed. BendPak strongly recommends making sure the Frames are in the correct location **before** anchoring them into place.

Anchor Bolt specifications are:

- **Length:** 4.75 inches
- **Diameter:** .75 inch
- **Effective embedment depth:** 2.75 inches, minimum
- **Anchor torque:** 85 – 95 ft. lbs.

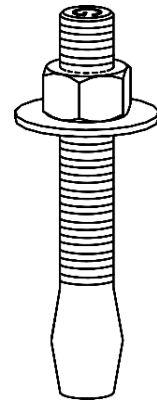

⚠ WARNING Use only the ALI-certified Anchor Bolts that came with your Lift. If you use components from a different source, you void your warranty and compromise the safety of everyone who installs or uses the Lift.

The figure below details the locations of the Anchor Bolt locations in each SP-7XE/F Base.

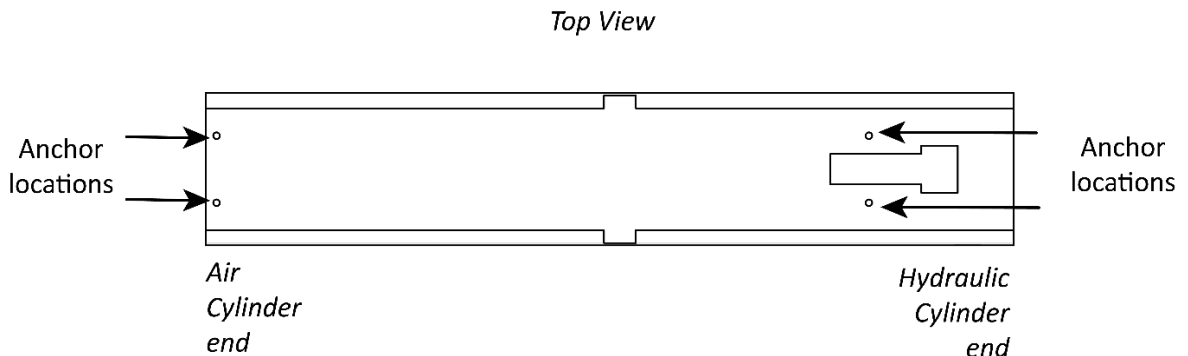

To anchor and level your Bases:

Both Ramps **must** be resting on the Top Safety Lock to perform this procedure.

1. Make sure the Bases are in the correct location, then use the holes in the Bases as guides, drill the holes for the Anchor Bolts. Four Anchor Bolt openings are located on the Base of the Frame.

Note: If you prefer, you can mark the Anchor Bolt hole locations, move the Frames out of the way, drill the holes, and then move the Frames back into position.

 **WARNING** Always wear appropriate eye protection and protective gear.

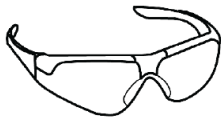

Drill in straight and perpendicular; do not let the drill wobble.

Use a carbide bit for concrete and hammer drilling applications (conforming to ANSI B212.15).

The diameter of the drill bit **must** be the same as the diameter of the Anchor Bolt. So, if you are using a 3/4 inch diameter Anchor Bolt, for example, use a 3/4 inch diameter drill bit. *Check the diameter of the drill bit before you begin!*

Note: BendPak recommends drilling a pilot hole first. If the final hole size is to be Ø.75 in. / Ø19 mm, drill a Ø.375 in. to Ø.5 in. (Ø9.5 mm to Ø12.7 mm) pilot hole first.

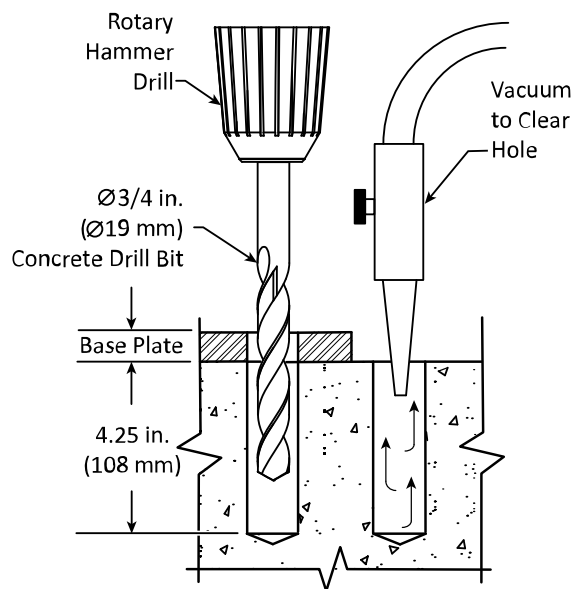

Pilot holes allow straighter drilling by removing the material directly in the center of the final drill. This reduces the amount of force required to keep the drill straight and perpendicular to the floor. Verify the drill flutes are at least 4.25 in / 108 mm long to aid in removal of the debris from the drill hole.

2. Use a vacuum to thoroughly clean each hole. If a Vacuum is not available, use a wire brush, hand pump, or compressed air.

Do not ream the hole. Do not make the hole any wider than the drill bit made it.

3. Do **not** immediately hammer the Anchor all the way in. Verify the Washer and Nut are in place, then insert the Anchor Bolt into the hole. You want approximately 1/4 inch to 1/3 inch (6 to 8 mm) of thread visible above the Nut. Tap it in until the threads are just entering the Base.

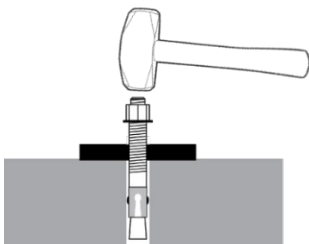

The Expansion Sleeve may prevent the Anchor Bolt from passing through the hole in the Base; this is normal. Use a hammer or mallet to lightly tap the Expansion Sleeve through the Base and down into the hole.

Even using a hammer or mallet, the Anchor Bolt should only go into the hole part of the way; this is normal. If the Anchor Bolt drops all the way in with little or no resistance, the hole is too wide.

The Lift Platforms must be parallel and square to each other before leveling and shimming can be effective.

4. **SP-7XE only:** Verify the Frame Assemblies are still within the chalk lines and parallel to each other by measuring the A and B dimensions from the chalk lines procedure. Drilling may have moved the bases. Adjust their positions until the A and B dimensions are equal.
5. **SP-7XE/XEF:** Begin by leveling front to back. The Frame Assemblies will be leveled to the highest point on the concrete floor. To find the highest point, use a four-foot level across the top of the Ramps or across the base of the Lift Ramps. Observe the bubble position to determine the direction and magnitude of the slope pointing to the highest area.
6. Beginning at the corner closest to the highest point, place a slotted shim under the Frame and around the closest Anchor Bolt to correct the out of level condition until each Frame Assembly is Level front to back. Do not shim more than 0.5 in. (12 mm) on any one Anchor.

Important: Use the slotted Shims provided with your Lift around the Anchor Bolt locations as required. Refer to the figures below.

7. Once the Ramp Assemblies are level front to back, level the Ramp Assemblies laterally across the Ramp Assemblies.

 **WARNING** Do not install your Lift on a surface with a slope greater than or equal to 3°. A slope exceeding 3° can lead to property damage, personal injury, or death. Small differences in floor level may be compensated for by proper shimming, but any slope in excess of 3° will have a negative effect on the Lift. If the concrete at the installation site has an excessive slope, create a concrete cutout, and pour a new concrete slab. Consult a concrete specialist in such a case.

8. Hammer or mallet the Wedge Anchors the rest of the way down into the hole. Stop hammering when the Washer is snug against the Base.
9. Torque each anchor to ≈85 - 95 ft. lbs.
10. Verify the Lift is still level. Adjust the number and position of shims if required.

Level the Lift Platforms

The Lift Ramp Assemblies must be parallel and square to each other before leveling and shimming can be effective. Both Ramps **must** be resting on the Top Safety Lock to perform this procedure.

To Level the Platforms:

1. Verify the Ramp Assemblies are still within the chalk lines and parallel to each other by measuring the A and B dimensions. Adjust their positions until the A and B dimensions are equal. Refer to the figure on the right.

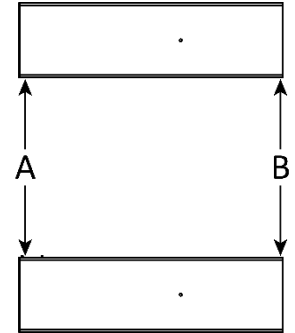

2. Begin by leveling lengthwise front to back. The Lift Ramps will be leveled to the highest point on the concrete floor. To find the highest point, use a four-foot level across the top of the Ramps or across the base of the Lift Ramps. Observe the bubble position to determine the direction and magnitude of the slope pointing to the highest area.

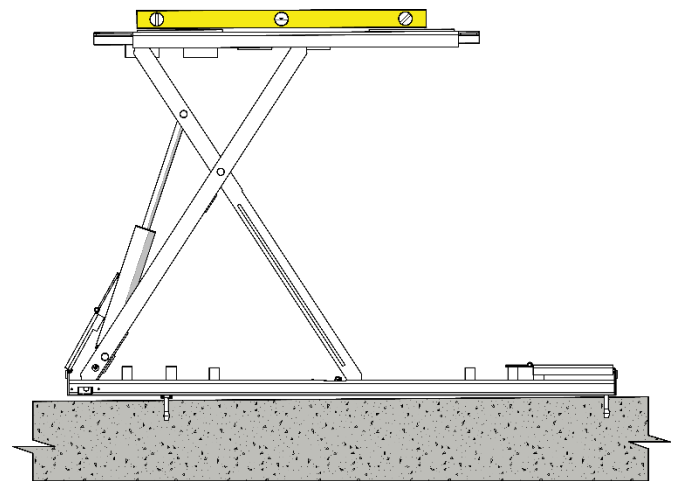

3. Beginning at the corner closest to the highest point, shim each Anchor Bolt hole location until each Lift Ramp is Level front to back.

Four Anchor Bolt openings are located on the Base of the Ramps, two at the rear and one at the front of each frame.

Important: Use slotted Shims around each Anchor Bolt location to help prevent the concrete from cracking near the Anchor Bolts. Refer to the figures on the right.

Level both Lift platforms.

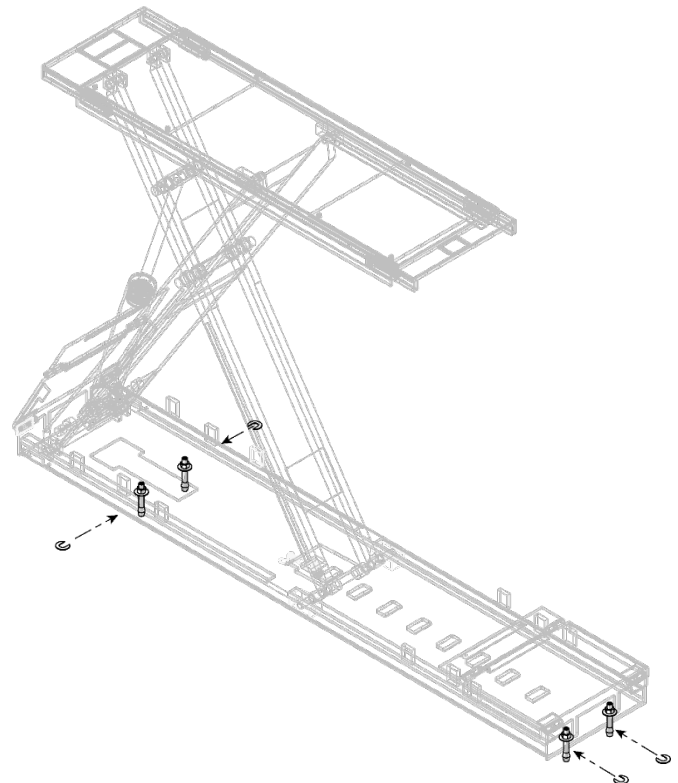

-
- Once the Ramp Assemblies are level front to back, level each Lift Platform laterally across the inside and outside of the Ramp Assemblies.

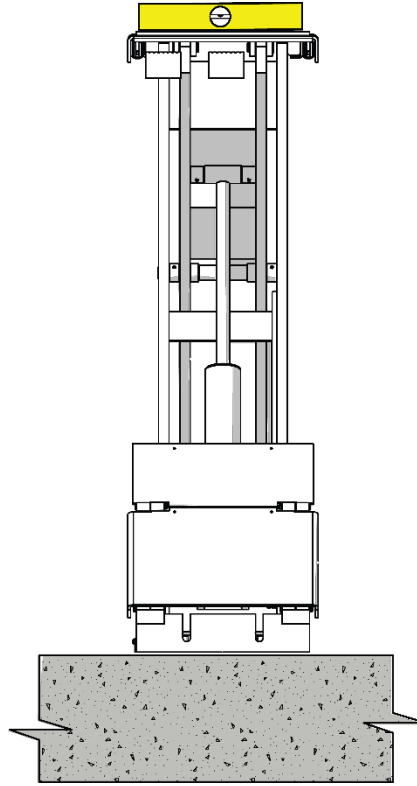

- Then verify the level condition across the platforms and correct with shims as required.

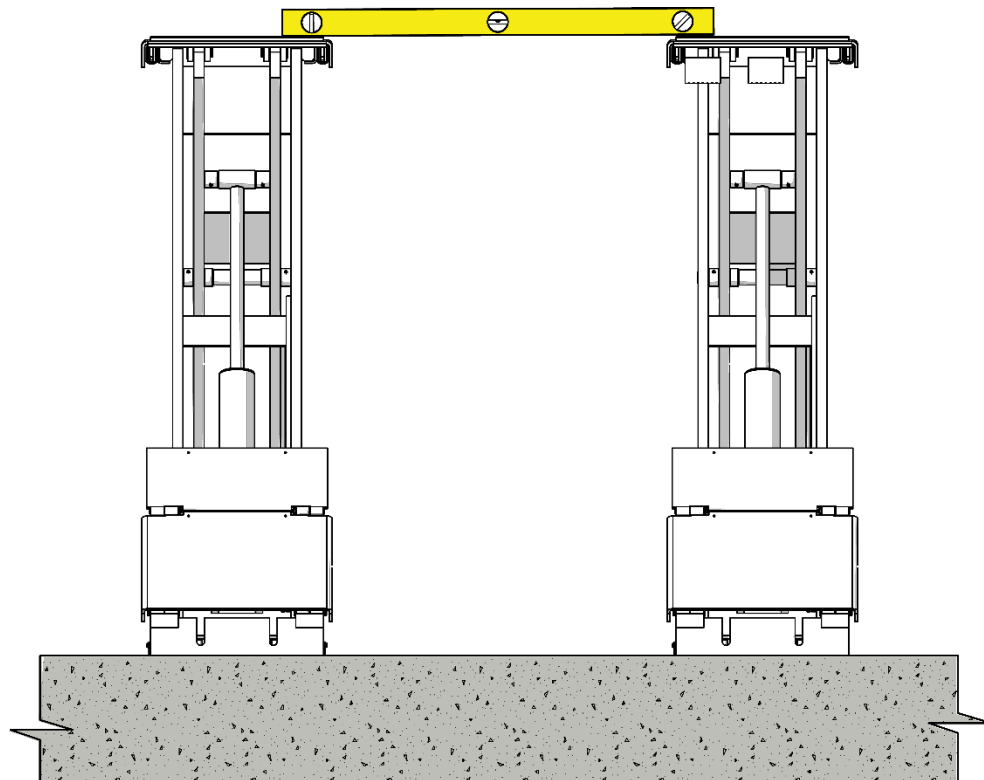

6. Wrench each Nut **clockwise** to the recommended installation torque, 85 – 95 ft-lbs. using a Torque Wrench.

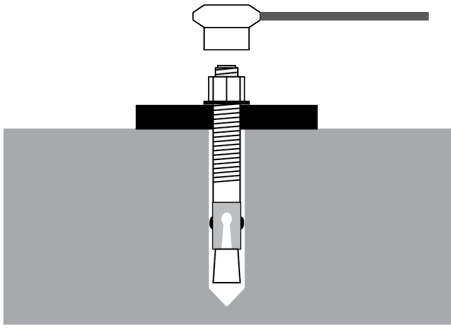

Important: Do **not** use an impact wrench to torque the Anchor Bolts.

Wrenching the Nut forces the Wedge up, pushing out the Expansion Sleeve and pressing it tightly against the Concrete.

Grouting the Lift Bases

If no shims were used, there is no requirement to grout the Bases of the Lift. Using Shims to level the Lift Platforms will create a void between the Lift Base and the existing concrete. These voids must be filled to support the downward force exerted by the Slide Blocks as they travel along the base. Tuck point a non-shrinking structural grout or cement to fill the voids and provide this support. A variety of structural grouts and cements are available: Quikrete® Fast Set® non-shrink grout is one such option.

Allow the material to cure to the manufacturer's specifications before applying weight to the Lift.

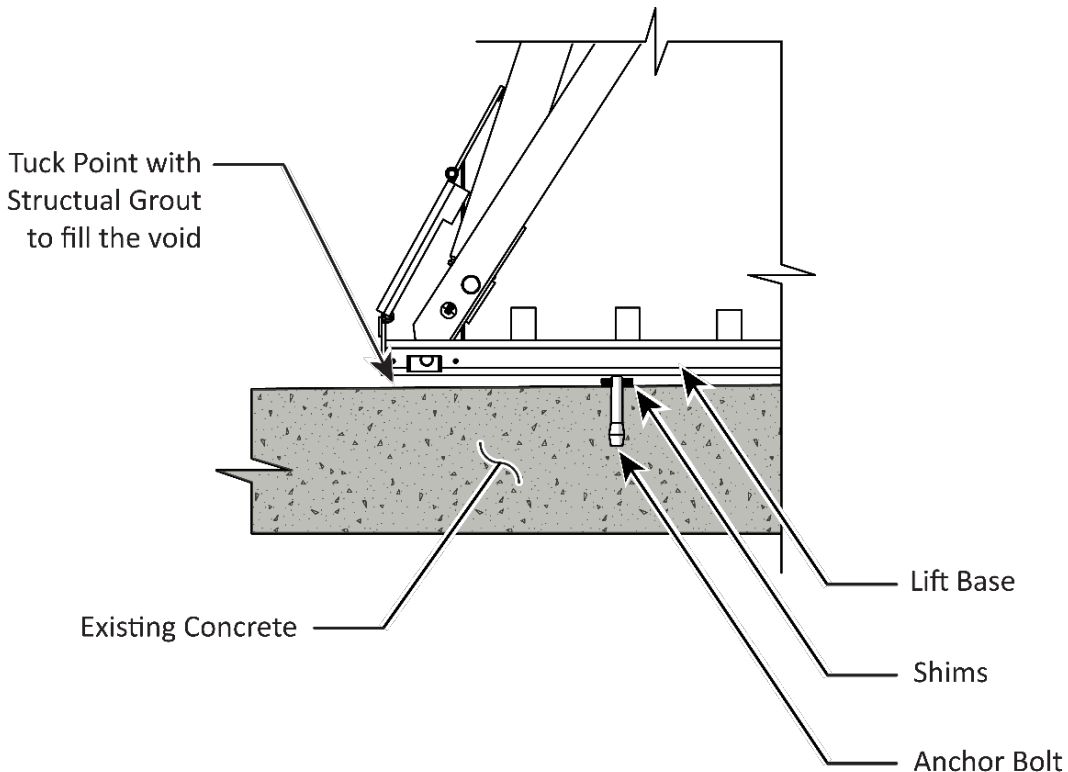

Assemble the Console and Attach the Power Unit

Some Consoles are shipped assembled, and others are not.

The included Hydraulic Hoses require the Console to be within 40 inches of the Lift.



Tip

If the Console is positioned farther than 40 inches from your Lift, Hydraulic Hoses that are long enough to reach the Lift from the desired location are required. You may be able to obtain these Hydraulic Hoses from a local hydraulics shop certified to fabricate Hydraulic Hoses, provide measurements to the local hydraulics shop. Longer Air Lines will also be required.



WARNING

If the Hydraulic Hose lengths are changed, **the new hose lengths must be within 5% of each other**. The SP-7XE/F Lift is a Hydraulically Balanced Lift. If the hose lengths vary by more than 5% there is a risk of the Platforms rising unevenly. Choose a certified Hydraulic Hose fabrication facility to assemble the replacement hoses.

The following illustration details the main components of the Console.

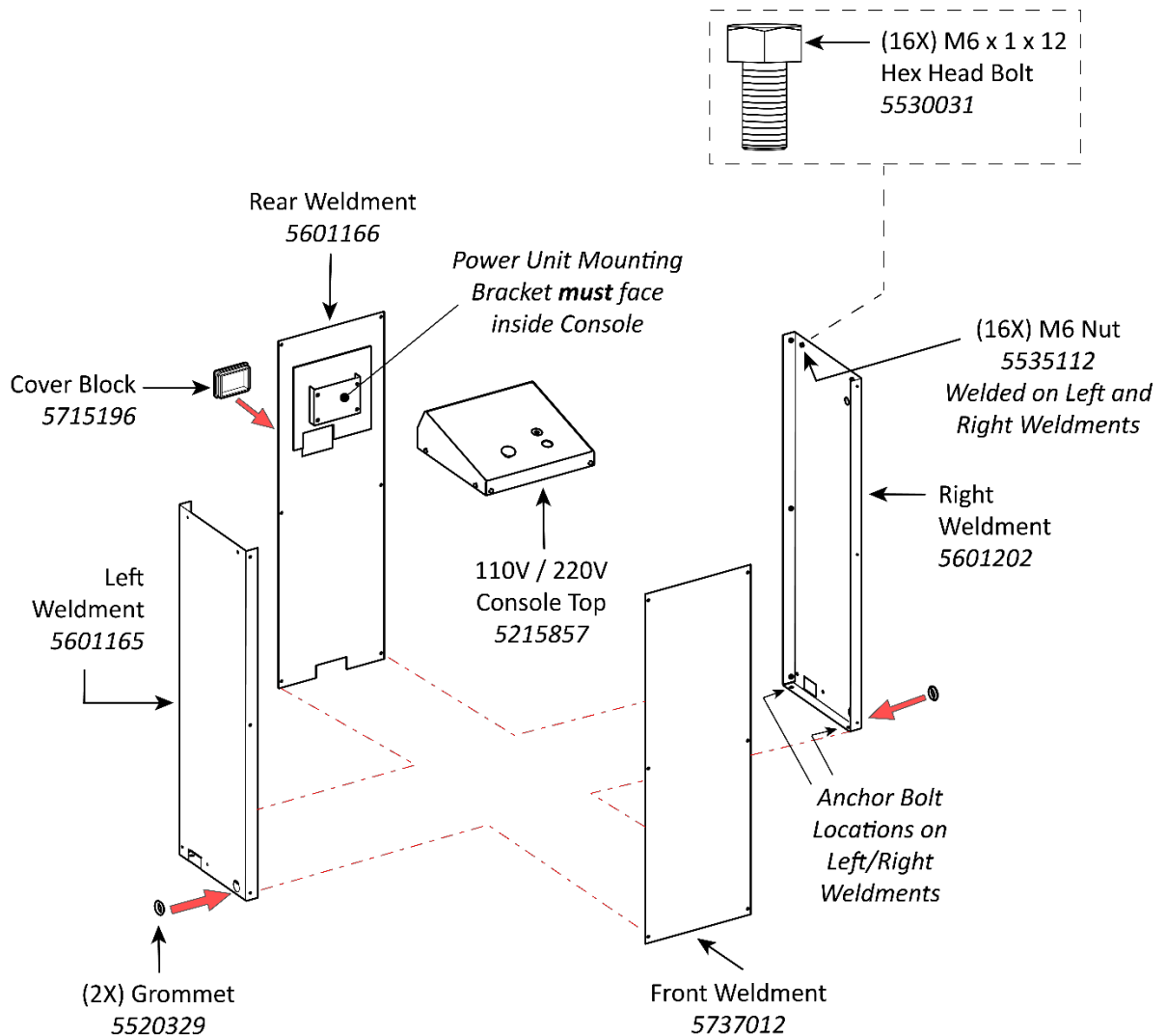

To assemble the Console and attach the Power Unit:

1. Select a site for the Console that permits operators to have a full, unobstructed view of the Lift.
If you are going to use the included Hydraulic Hoses, the Console can go on either side of the Lift, up to 40 inches away from the closest Frame.
2. Arrange all the Console components near where you are going to assemble them.
3. Install the Grommets into place near the bottom of the Left and Right Weldments.
4. Put the Left Side on the left and the Right Side on the right, then attach both to the Rear Weldment, making sure to orient the Rear Weldment so that the **Power Unit Mounting Bracket is on the inside**.

The Rear Weldment attaches on the *outside* of the two sides.

NOTICE Do not attach the Nuts at the top of the sides or the Rear Weldment at this point; these will be attached later when you are ready to attach the Console Top.

5. Remove the Power Unit from the shipping material.
6. Attach the Power Unit to the Power Unit Plate on the inside back of the Console using the supplied Nuts and Bolts.

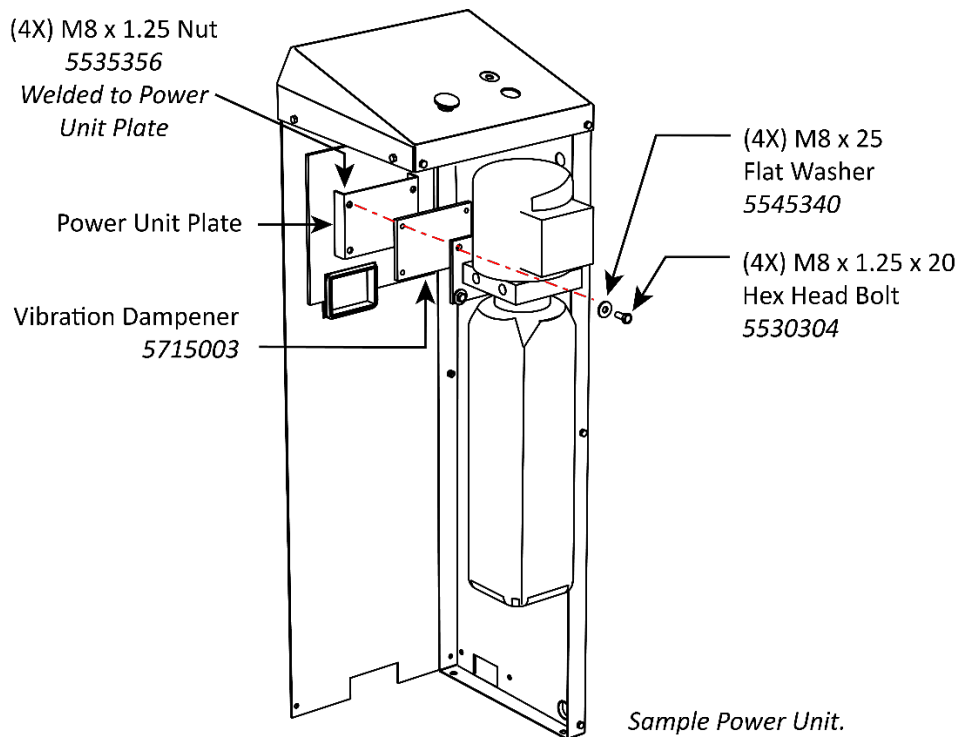

CAUTION

The Power Unit is heavy. BendPak recommends having one person hold the Power Unit in place while another person bolts it into place.

Important:

Do not connect the Power Unit to the power source at this point.

Anchor the Console

The following procedure includes instructions for anchoring the Console into place. If you prefer, you can defer anchoring the Console.

Anchoring the Console is a permanent decision. Delaying the anchoring allows you to evaluate how well the first choice performs. It is easier to change the Console location later if it is not anchored.

The Console may be mounted on either the Left or Right side of the Lift, *up to 40 inches away*. The Console must be on the Cylinder end of the Frames in a direct line from the rectangular opening in the Lift Base used for routing the Hydraulic and Air Lines.

When you are ready to anchor the Console into place, return to this section and follow the instructions.

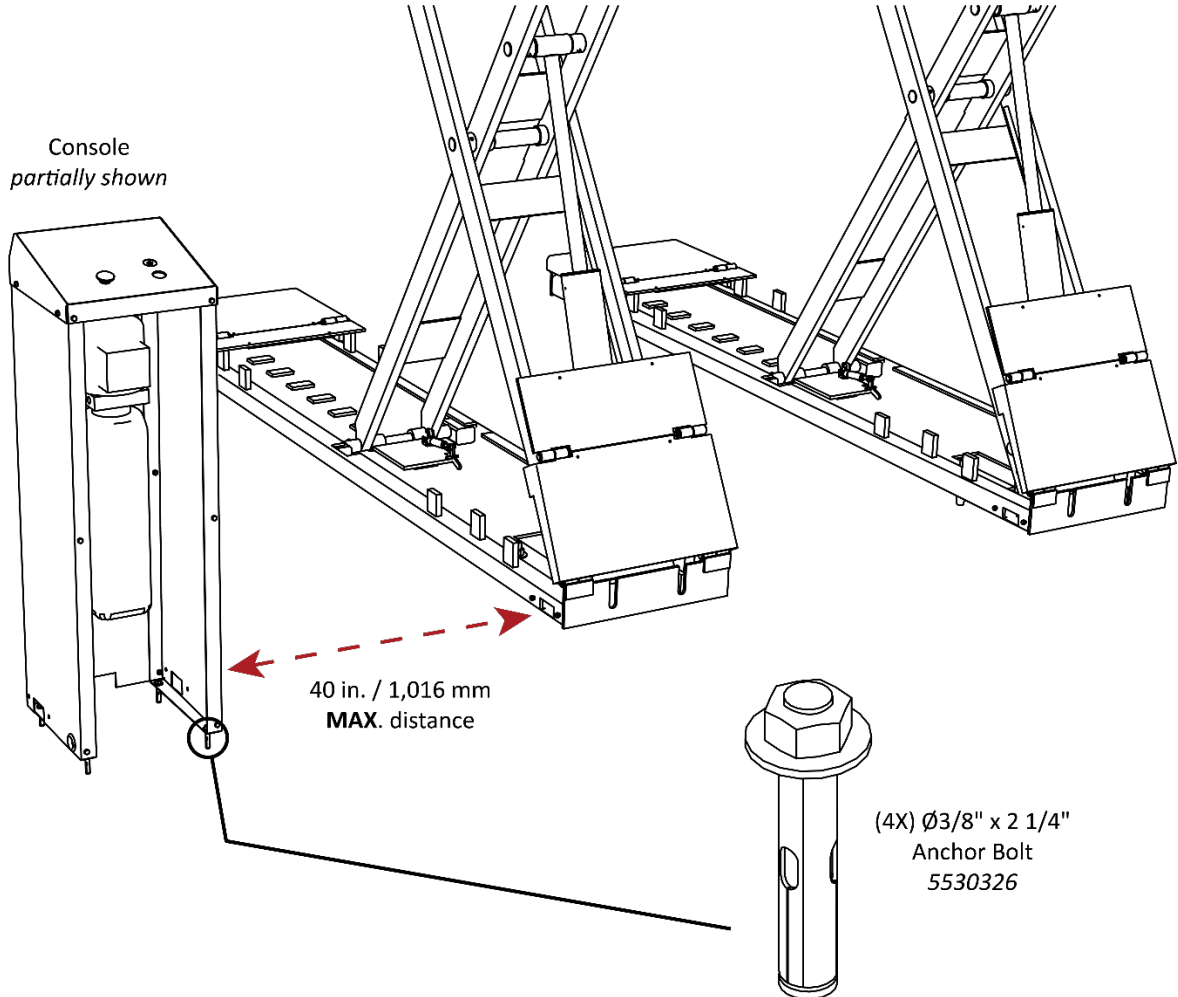

To Anchor the Console:

1. Remove the Front Console Weldment and the four M6 Hex Head Bolts that hold it in place; this allows access to the inside of the Console to insert the Anchors.
Keep the components nearby, you will need them again soon.
2. Locate the mounting holes on the bottom of the Left and Right Console Weldments (on the inside). The Anchor Bolts go into these holes.

Important: BendPak recommends marking the holes with the Drill through the Console Base, then moving the Base out of the way to finish drilling the holes to the 3 in. depth.













3. Using the holes in the Console Base as a guide, drill the holes $\text{\O}3/8$ in. diameter by 3 in. deep into the Concrete.
Go in straight; do not let the drill wobble. Use a carbide bit for concrete applications (conforming to ANSI B212.15).

 **WARNING** Always wear the appropriate eye protection and protective equipment.

4. Remove all dust and debris from the holes.
Use a wire brush, vacuum, hand pump, or compressed air. Do **not** ream the hole. Do **not** make the hole any wider than the drill bit made it.
5. Move the Console back over the drilled holes.
6. Retrieve the four Anchor Bolts from the Parts Bag, make sure the Washer and Nut are in place, then insert the anchor Bolt into the mounting hole in the Console and through the drilled hole in the Concrete.
7. Hammer or mallet the Wedge Anchor the rest of the way down into the hole.
Stop hammering when the Washer is snug against the Console Base.
8. Wrench the Nut **clockwise** to the recommended installation torque, 10-15 ft. lbs., using a Torque Wrench.

 **CAUTION** Do not use an impact wrench to torque the Anchor Bolts.

Hydraulic System Warnings

-  **DANGER** Failure to observe these warnings can result in serious personal injury including, in rare cases, death.
-  **WARNING** The Hydraulic Hoses and connections **must** be inspected before any attempt to raise a Vehicle is made.
-  **WARNING** Double check to **verify** all Hydraulic Hose connections and fittings, including unused auxiliary port plugs on the Power Unit, the Flow Divider, the Cylinders and anywhere else in the Hydraulic System are tightened.
-  **WARNING** The Power Unit is a Hydraulic Pump capable of developing pressures in excess of 5,000 psi (345 BAR). A pressure relief valve is used to set the pressure to the desired level. Tampering with, adjusting, modifying, or removing the relief valve is extremely dangerous and is not recommended. Only trained Hydraulics Technicians should make adjustments to the relief valve, using calibrated Hydraulic Pressure gauges to assure the proper pressure setting is achieved.
-  **WARNING** Changes to the output pressure may render the power unit incompatible with pressure limitations of other components in the Hydraulic Circuit. This may cause catastrophic failure of those components, and could result in property damage, serious personal injury, or death.
-  **DANGER** The Hydraulic System can contain high pressure which, if suddenly released, can cause severe injury or death.
-  **WARNING** Do **not** attempt to connect or disconnect Hydraulic Hoses while the equipment is loaded or while a Vehicle is on the Lift, or the Hydraulic System is under pressure.
-  **WARNING** Keep bare hands away from Hydraulic Fluid; always wear gloves when handling Hydraulic Fluid, Cylinders or Hydraulic Hoses.
-  **WARNING** When handling Hydraulic Fluid, always observe the safety instructions from the manufacturer.
-  **WARNING** **Always** promptly clean any Hydraulic Fluid spills. If a leak is the source of the spill, lock out the Lift to prevent use until the Hydraulic System is repaired.
-  **WARNING** Do **not** attempt to service the Power Unit through the rear panel. Only access the Power unit through the Front of the Console.
-  **WARNING** If you choose to change the Hydraulic Hose lengths, **the two hose lengths must be within 5% of each other**. The SP-7XE/F Lift is a Hydraulically Balanced Lift. If the hose lengths vary by more than 5% there is a risk that the Platforms will rise unevenly. Choose a certified Hydraulic Hose fabrication facility to assemble any replacement hoses.



IMPORTANT! PLEASE READ NOW



Hydraulic Fluid Contamination poses a serious issue for your Lift; contaminants such as water, dirt, or other debris can get into the Hydraulic Hoses and Fittings on the Lift, making your new Lift inoperable and unusable.

The Lift is shipped with clean components; however, BendPak strongly recommends that you take secondary precautions and clean all Hydraulic Hoses and Fittings prior to making connections. It is better and less costly to take these extra steps now so that you do not need to take your Lift out of service later to fix issues that could have been prevented at the time of installation.

There are several ways to clean Hydraulic Hoses and Fittings:

- **Compressed Air.** Use an air compressor to blow out contaminants from each Hydraulic Hose and Fitting prior to installation. Clean, dry air is preferred. Wear ANSI-approved eye protection (safety glasses, goggles, or face shield) when using compressed air for cleaning. Never point an air hose nozzle at any part of your body or any other person.
- **Fluid Flushing.** If the Hydraulic Fluid is clean and compatible with the system fluid, you can flush Hoses and Fittings to create turbulent flow and remove particulates. Always ensure that the fluid itself is contaminant-free. Some additional steps that will help keep the Hydraulic Fluid clean:
- **Remove old thread seal tape.** Some ports on the Hydraulic Cylinders are shipped with temporary plugs secured with thread seal tape, so make sure to thoroughly remove any leftover thread seal tape that may inadvertently enter the Hydraulic System.
- **Use a liquid thread sealant only.** Liquid thread sealant (Loctite™ 5452 or similar) is recommended. Do not use thread seal tape on any fitting. Liquid thread sealant is recommended for NPT connections, fine for JIC connections, but *not* necessary for O-ring (ORB) connections.
- **Always use clean equipment.** If you use a dirty bucket or funnel to transfer the Hydraulic Fluid into the Hydraulic Fluid Reservoir, the contaminants will likely be introduced into the Fluid. When using cleaning rags, use a lint-free rag.
- **Proper storage.** Keep the Hydraulic Fluid sealed in its container until ready for use; store the Fluid in a clean, dry, and cool area.
- **Cover the Hoses and Fittings.** Before installation, do not leave the ends of the Fittings exposed; the same applies for the Hydraulic Hoses. As a rule, keep the Hydraulic Hoses and Fittings capped and in a clean area until ready for use.
- **Filter the new Hydraulic Fluid.** Just because it is new does not necessarily mean it is *clean*. Use an offline filtration cart or kidney loop system to make sure the Hydraulic Fluid is clean before being transferred into the Hydraulic Fluid Reservoir (even using a heavy-duty nylon mesh screen is better than trusting what is left at the bottom of the barrel).
- **Avoid mixing different types of Hydraulic Fluid.** If Hydraulic Fluid needs to be replaced, make sure to flush the Hydraulic System of the old Hydraulic Fluid before you add the replacement Fluid; do not mix the two together.

About Thread Sealants

Liquid Thread Sealant lubricates and fills the gaps between the Fitting threads and leaves no residue that could contaminate the Hydraulic Fluid.

Other types of Thread Sealants (like Teflon Tape) can shred during installation or removal and eventually enter the Hydraulic System.

Thread Sealant can be used with most Hydraulic Fittings, although you only need to use it with NPT connectors.

Apply the thread sealant when the ambient temperature is between +46.5°F to +70°F (+8°C to 21°C)



To apply Thread Sealant:

1. Make sure the Fittings and connectors you are going to use are clean and dry.
If you are adding Thread Sealant to a Fitting or connector that has already been used with a different sealant, use a wire brush to thoroughly remove the old sealant before adding more.
2. Skipping the first thread, apply a small amount of Thread Sealant to the next four threads of the Fitting.

⚠ WARNING Always wear the proper protective equipment when handling Thread Sealant.

You only need a small amount because the sealant spreads to the other threads as it is tightened into place.

If you put too much, the excess liquid will be pushed out when the Fitting is tightened; use a rag to wipe the excess.

3. Tighten the Fitting into the connector; do **not** over tighten the Fitting.
4. Allow the **24-hour** manufacturer-recommended curing time before pressurizing the system.

Connect the Hydraulic Hoses

The SP-7XE Lifts come with two Hydraulic Hoses, both of which are routed from one of the two Hydraulic Power Ports on the Power Unit to one of the Hydraulic Cylinders. The two Hydraulic Hoses are the same length, so it does not matter which Lift Frame they attach to.

Note: Hydraulic Hoses and Fittings are different from Compression Lines and Fittings. This section covers Hydraulic Hoses and Fittings only.

The following illustration shows how to route the Hydraulic Hoses from the Console to the Hydraulic Cylinders.

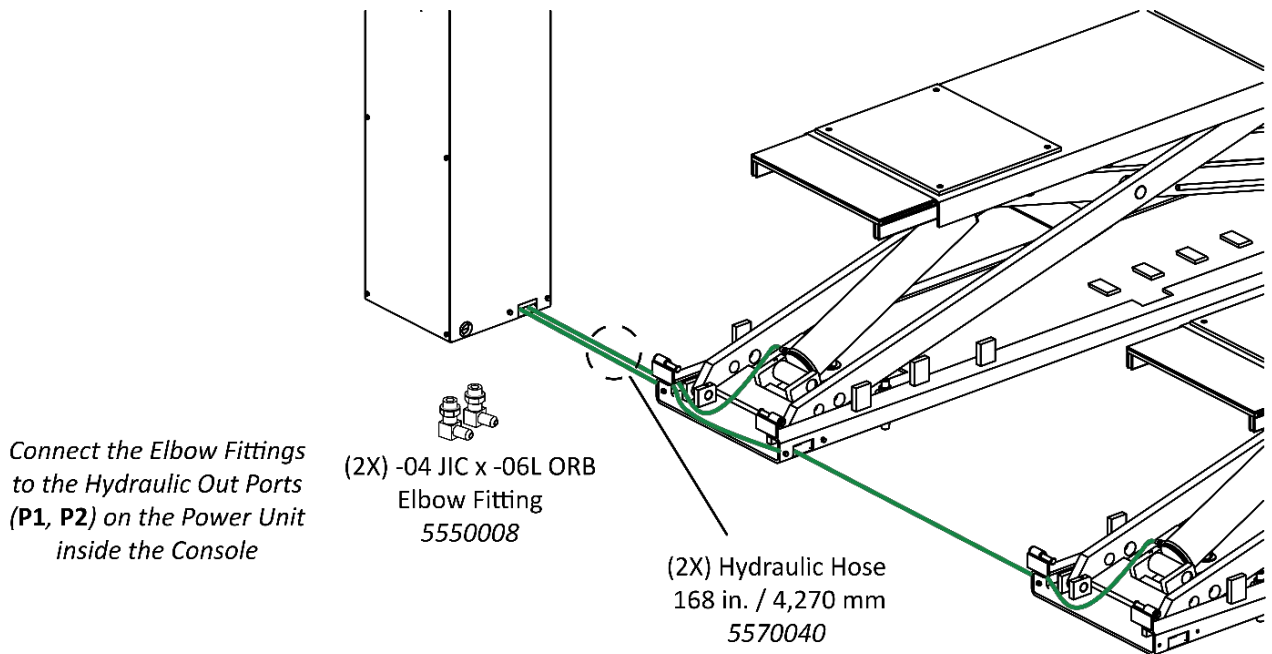

The following illustration shows a detail of the connections to the Hydraulic Cylinders.

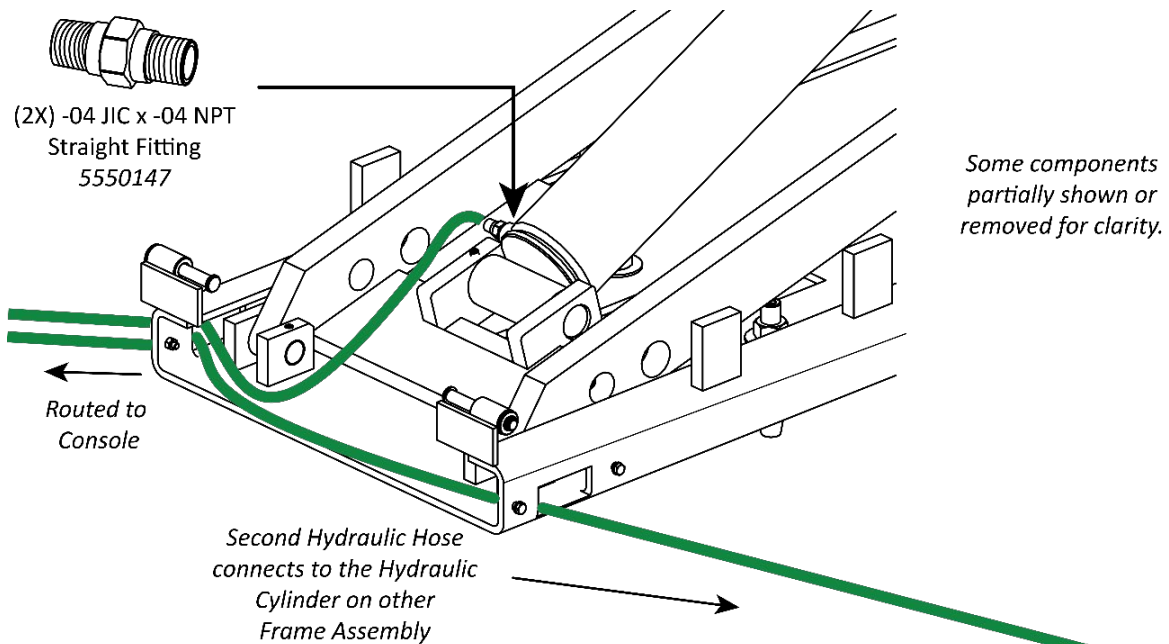

To connect the Hydraulic Hoses:

1. Locate the two Hydraulic Elbow Fittings (5550008), two Hydraulic Hoses (5570040), and two Hydraulic Straight Fittings (5550147).
2. Remove the Shipping Plugs from the two Hydraulic Pressure Ports on the Power Unit, (labelled **P1** and **P2**), then attach a Hydraulic Elbow Fitting to each Hydraulic Power Port.
See **Wiring Diagrams** for the Hydraulic Port locations on your Power Unit.
3. Remove the Shipping Plugs from the Hydraulic Port at the bottom of each Hydraulic Cylinder, then visually inspect and clean the Port threads.
4. Attach a Hydraulic Straight Fitting to each of the Hydraulic Ports.

Use Thread Sealant on NPT Threads only.

5. Attach one of the Hydraulic Hoses to one of the Hydraulic Elbow Fittings on the Power Unit, then attach the other end of the same Hydraulic Hose to a Hydraulic Straight Fitting at the bottom of one of the Hydraulic Cylinders.

NOTICE Make sure to route the Hydraulic Hose through the rectangular openings in the Cylinder end of the Bases. Both Hydraulic Hoses and the air line will route through these openings.

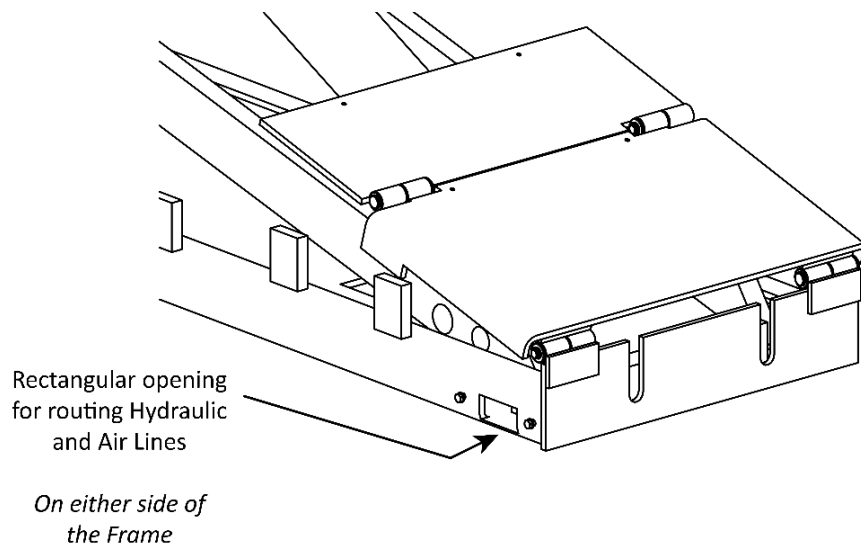

If you are attaching the Hydraulic Hose that goes to the *closest* Hydraulic Cylinder, there will be extra length; just coil up the extra length and leave it inside the Console.

Finger tighten the connections.

6. Attach the second Hydraulic Hose to the other Hydraulic Elbow Fitting on the Power Unit, then attach the other end to the Hydraulic Straight Fitting at the bottom of the other Hydraulic Cylinder.

Finger tighten the connections.

7. Make sure both Hydraulic Hoses are correctly routed and do not have any kinks, then use appropriate tools to **securely** tighten the connections.

Working with Compression Fittings and Tubing

Your Lift comes with a roll of ¼ inch, black, polyethylene Tubing (also called Poly-Flo® Tubing) that is used with Compression Fittings to attach to the Air Cylinders and the Air Assist Connectors.

Note: Compression Fittings are different from Hydraulic Fittings. **This section covers Compression Fittings only.**

The components involved with Compression Fittings include:

8. **¼ inch, black, polyethylene Tubing.** The Air Lines require multiple Tubing pieces to make the necessary connections. Create the Tubing pieces by cutting lengths from the long roll of Tubing supplied with your Lift.
9. **Straight Compression Fittings.** The Air Line uses two Straight Compression Fittings, one at the top of each Hydraulic Cylinder.
10. **Elbow Compression Fittings.** The Air Line uses two Elbow Compression Fittings, one on each Air Cylinder.
11. **Tee Compression Fittings.** The Air Line requires three Tee Compression Fittings.
12. **Nuts, Ferrules, Rods, and Threads.** Each connector on Straight, Elbow, and Tee Compression Fittings have a Nut, Ferrule, Rod, and Threads (see drawing below). The Nut holds the Tubing and Fitting together. The Ferrule compresses when you tighten the Nut on the Threads to make a secure connection. The Rod goes inside the Tubing so that nothing leaks out.

The following drawing shows the components of a connector on a Tee Compression Fitting.



Important: **Ferrules can only be tightened once.** When you tighten the Nut on the Threads, the Ferrule gets compressed; it literally changes shape and **cannot** be used again.

To connect Tubing to a Compression Fitting:

1. Push the Tubing through the Nut and over the Rod.
Do not push hard; you only need the Tubing to travel a small distance over the Rod. You cannot see the Ferrule at this point, but the Tubing must thread through the Ferrule and over the Rod.
2. Slide the Nut on the Tubing **away from the Fitting**; if the Nut is still on the Threads, unscrew it from the Threads and then slide it away from the Fitting. See the figure above.
3. Slide the Ferrule over the Tubing, away from the Fitting and towards the Nut.
4. With the Nut and the Ferrule out of the way, push the Tubing farther over the Rod until it stops.
5. Slide the Ferrule and the Nut back to the Threads on the Fitting.

The Ferrule goes around the Rod and under the Threads. The Nut rotates onto the Threads.

6. Tighten the Nut.

Remember that the Ferrule can only be used once; do not tighten the Nut until everything is ready.

Connect the Air Line

The SP-7XE Lifts use hydraulic pressure to move the platforms off the Safety Locks. Air Pressure is used to raise and lower the Safety Latch Weldments away from the Safety Lock Blocks freeing the Platform to be raised or lowered.

NOTICE It is the owner's responsibility to provide an air supply with a minimum of 30 psi / 3 CFM, regulated to a maximum of 125 psi).

The air pressure supply is distributed to the Air Cylinders using ¼ inch, black, polyethylene Tubing (also called Poly-Flo® Tubing), supplied with the Lift. Cut the tubing into appropriate lengths. Three sections of tubing are required.



Tip BendPak recommends planning out and measuring the path of the Air Line **before** cutting the tubing.

The following figure details the route the Air Lines take from the Console to the Air Cylinders.

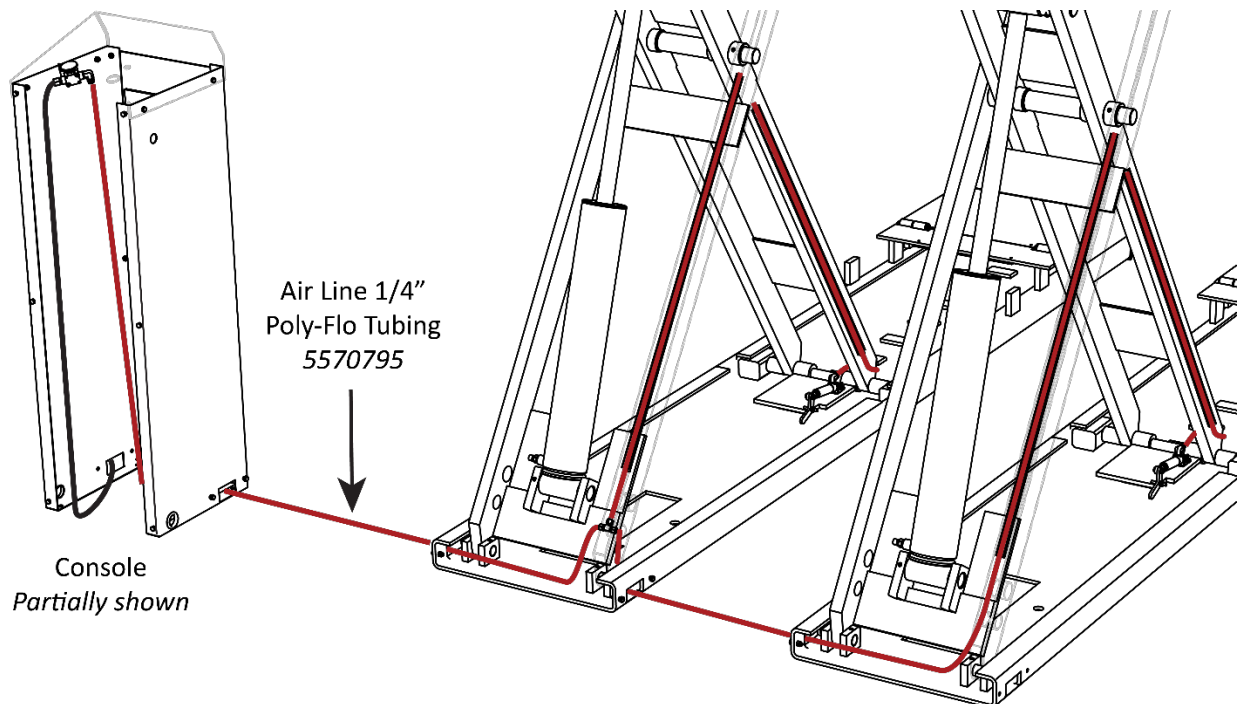

To connect the Air Line:

1. If the two Elbow Compression Fittings (5550087) are not already connected to the top of the Air Cylinders, connect them now.

Use Thread Sealant on NPT Threads only.

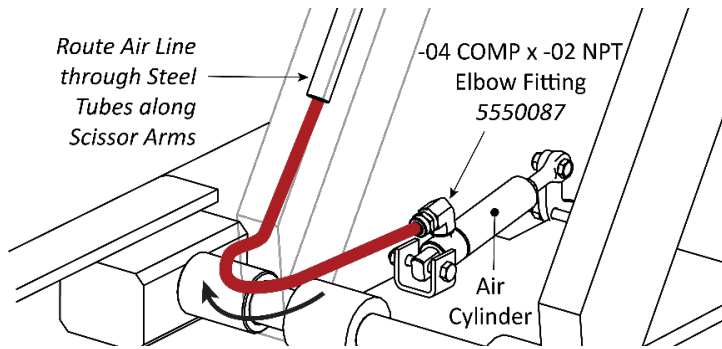

2. Locate the roll of ¼ inch, black, polyethylene Tubing and the Tee Compression Fitting (5550395).
3. Cut the tubing into three sections of appropriate lengths for your installation. See the drawing on the previous page for additional information.
4. Connect the three tubing sections and Tee Compression Fitting to the Compression Fittings on the Air Cylinders, routing the Air Line through the Steel Tubes along the Scissor Arms on the Lift.

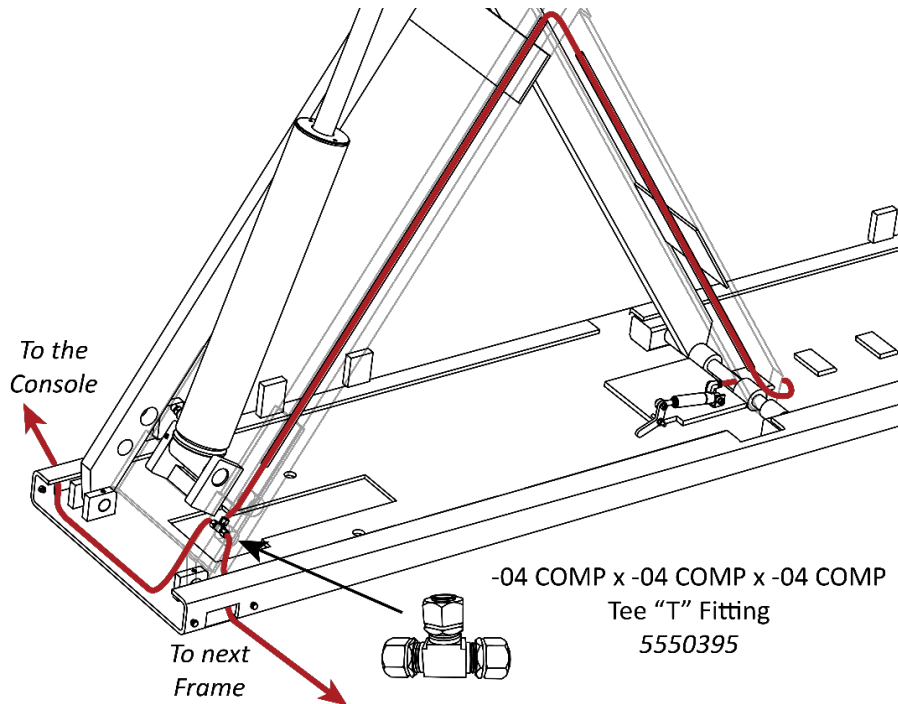

5. On the underside of the Console Top, attach the male end of a Compression Elbow Fitting to the CYL connector on the Pushbutton Air Valve, then connect the final Air Line tubing section to the compression end of the Elbow Compression Fitting you just installed.

Use Thread Sealant on NPT Threads only.

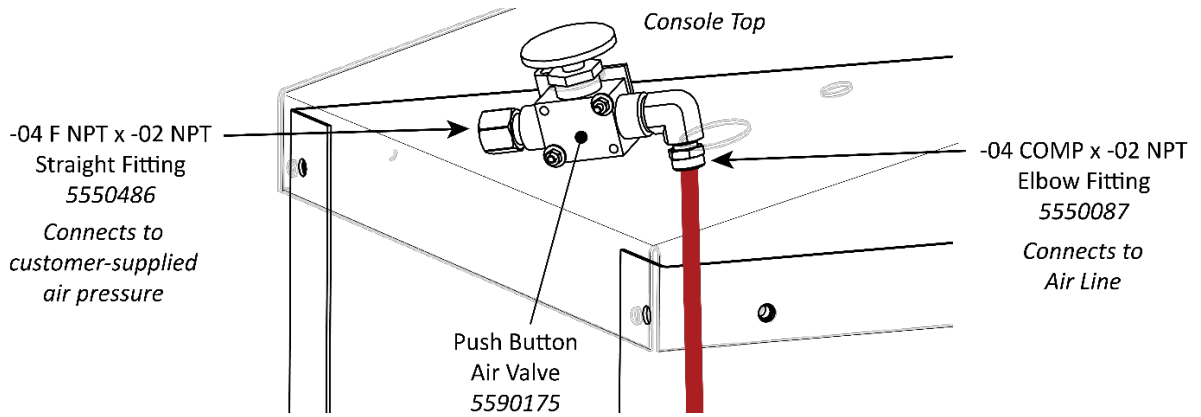

Pushbutton is above the Console Top; all other components are under the Console Top.

6. On the underside of the Console Top, attach the male end of a Straight Pipe Fitting to the **IN** connector on the underside of the Pushbutton Air Valve, then connect the customer-supplied air pressure to the other end of the Straight Pipe Fitting.

Install the Hose Covers

The Hose Covers are required to protect the Hydraulic Hoses and Air Line from damage.

The Inner Hose Cover is positioned between the Frame Assemblies; the Hose Cover is adjustable 40 – 46 inches / 1,016 – 1,168 mm.

The Outer Hose Cover is positioned between the Console and the closest Frame Assembly; it is **not** adjustable for length. The Outer Hose Cover measures 40.25 in. / 1,022 mm long.

To install the Hose Covers:

1. Locate the Inner and Outer Hose Covers, eight M6 Hex Head Bolts, M6 Flat Washers, and M6 Nyloc Nuts.
2. Position the Inner Hose Cover between the Frame Assemblies, making sure to cover the Hydraulic Hoses and Air Line, and then secure it to the Frame Bases using four M6 Hex Head Bolts, M6 Washers, and M6 Nuts.

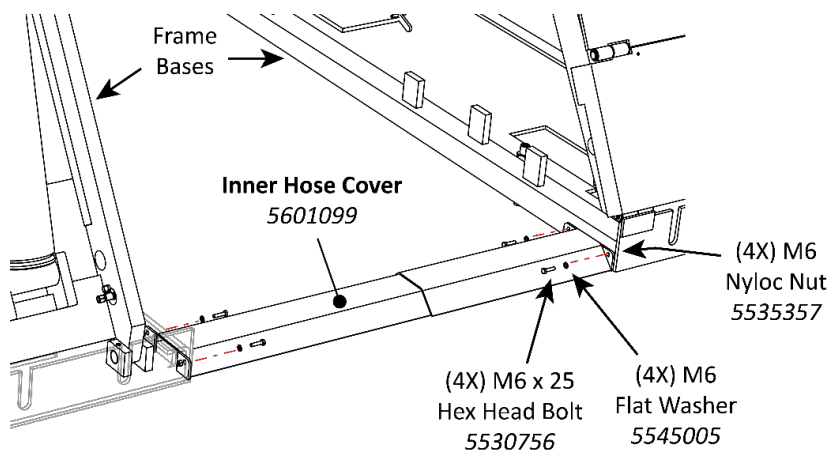

CAUTION

Use care to not crush or pierce the Hydraulic Hoses and Air Line underneath the Hose Covers.

3. Position the Outer Hose Covers between the Console and the nearest Frame Assembly, making sure to cover the Hydraulic Hoses and Air Line, and then secure it to the Console Base and Frame Base using four more M6 Hex Head Bolts, M6 Washers, and M6 Nuts.

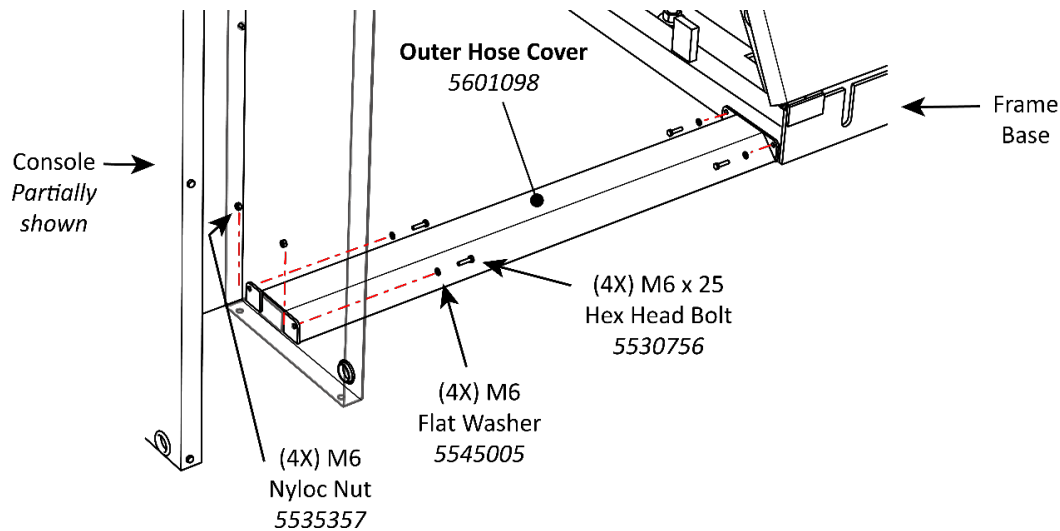

Electrical and Thermal Disconnect and Facility Power

The Power Unit requires no assembly. Attach the Power Unit to the back of the Console (described in [Set Up the Console and Attach the Power Unit](#)) and then an Electrician will make the connections, described in this section.

The Standard Power Unit for your Lift is 208-240 VAC, 50/60 Hz, 1 phase.

⚠ DANGER A licensed Electrician must perform all wiring. Do not perform **any** maintenance or installation on the lift without first verifying that main electrical power has been disconnected from the lift, locked out or tagged out and **cannot** be re-energized until all procedures are complete.

The Power Unit has multiple connections:

- **Hydraulic Hoses.** The Lift has two. They both connect to the Power Unit on one of its two Hydraulic Power Out Ports. *They should already be connected.*
- Refer to [Connect the Hydraulic Hoses](#) for full details.
- **Console Buttons.** Power Unit controls connect to the top of the Console enabling the **Raise** and **Lower** buttons. The **Safety Lock Release** is also on the top of the Console, but it is not connected to the Power Unit.
- **Power Source.** The Power Unit connects to an appropriate, incoming power source. A licensed Electrician is **required** to make this connection.

To connect the Power Unit to Electrical Power:

1. The Electrician will route and protect wiring from the facility power to the Lift Console, in accordance with national, state, and local electrical codes.
2. Remove the Console Top if it is currently in place.
3. For the Control Buttons on the Console, the wiring is connected to the appropriate Button at the factory. Simply connect them mechanically to the Console Top.
4. The Electrician will install a Power Disconnect Switch.

⚠ WARNING A Power Disconnect Switch is **not** provided with this equipment. This is a National Electrical Code (NEC) requirement. They are designed to interrupt main electrical power in the event of an electrical circuit fault, emergency, or when equipment is undergoing service or maintenance.

Only install a Power Disconnect Switch that is properly rated for the incoming power source.

Your Power Disconnect Switch must be installed so that it is within **easy reach of the operator** or in their line of sight. The Power Disconnect Switch must be **clearly marked** to indicate its purpose.

If you are not clear where to install the Power Disconnect Switch, consult with your Electrician.

⚠ DANGER Installing a Power Disconnect Switch **must** be performed by a licensed, Electrician in accordance with all applicable local electrical codes.

Have the Electrician select a **UL-listed** Power Disconnect Switch.

5. The Electrician will locate the Electrical Junction Box on the Power Unit Motor, open the Box, remove the Pigtail, and then wire to the Power unit motor to the Power Disconnect Switch. Alternatively, the Electrician could connect directly to the facility electrical system protected by an appropriate circuit breaker.

The Power Cord and Plug are **not** supplied with the Lift.

Refer to the **Wiring Diagrams** for proper wiring information.

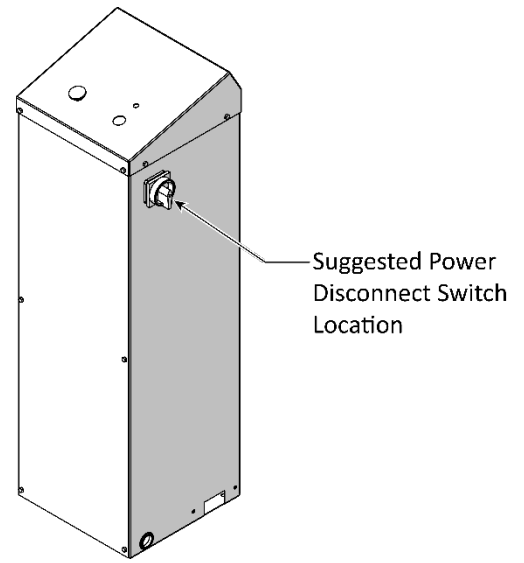

Important electrical information:

6. Improper electrical installation can damage the Power Unit motor; this damage is not covered under warranty.
7. Use a separate circuit breaker for each Power Unit. Protect each circuit with a time-delay fuse or circuit breaker. Refer to the **Wiring Diagrams** for Voltage and current information.

Install a Thermal Disconnect

⚠ WARNING A thermal disconnect is not included with the Lift. The Electrician will supply an appropriate thermal disconnect. The motor on the Power Unit includes no thermal overload protection.

Have the Electrician connect a Thermal Disconnect Switch or overload device that will shut down the equipment in the event of an overload or an overheated motor.

⚠ DANGER A licensed Electrician must install a Thermal Disconnect Switch in accordance with all applicable national, state, and local electrical codes. Do not perform **any** maintenance or installation on the Lift without first making sure that the main electrical power has been disconnected from the Lift and **cannot** be re-energized until all procedures are complete.

High electrical current that exceeds the motor's full load amps (FLA) rating may result in permanent damage to the motor. **Do not exceed the rated duty cycle of the motor.**

Lubricate the Lift

There are several Lubrication areas on **each** Lift Frame:

- **Lubrication areas along the Base Weldment** where the Slide Blocks travel only.
- **Lubrication areas under the Platform** where the Slide Blocks travel only.
- **Lubricate all scissor pivot points**

Use a small amount of White Lithium Grease or similar on each Lubrication Area before you use the Lift and monthly after putting the Lift into service. Refer to the figures below for the Lubrication areas.

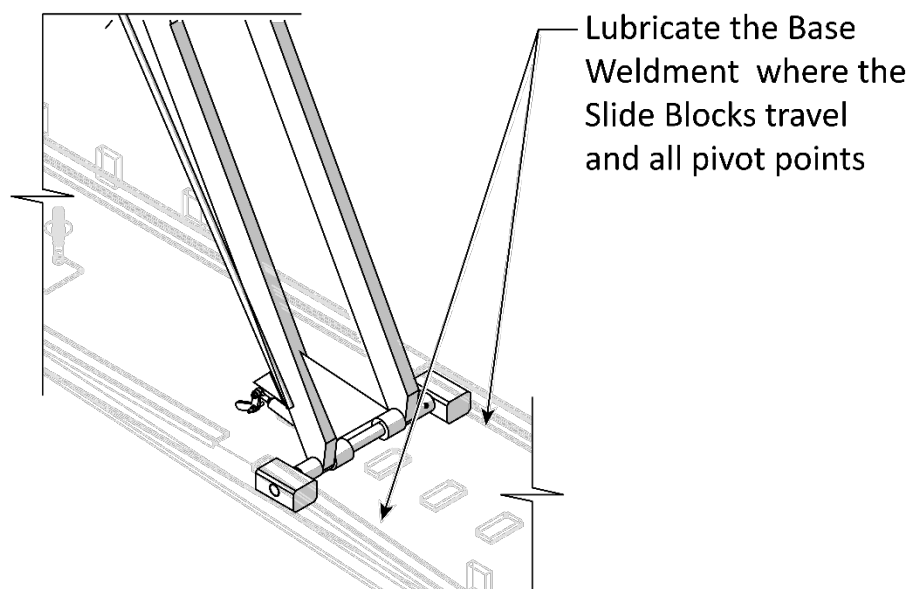
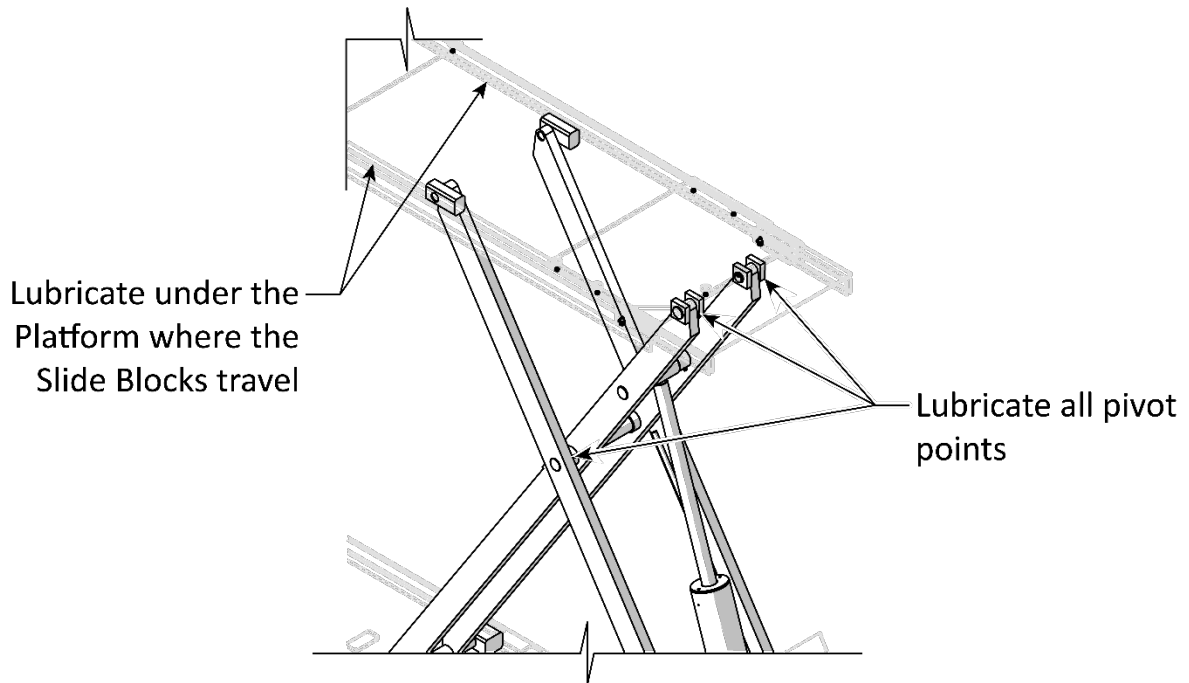

Drawing not to scale. Not all components shown.

Fill the Hydraulic Fluid Reservoir

The Hydraulic Fluid Reservoir on the Power Unit must be filled with Hydraulic Fluid or automatic transmission fluid before you **begin** normal operation of the Lift. When you receive the Lift, the Hydraulic Fluid Reservoir is empty. The Power Unit will not work correctly until it is filled with approved fluids.

The Hydraulic Fluid Reservoir holds 3.5 – 3.7 gallons (13.25 – 14 liters) of fluid, depending on the Power Unit.

 **WARNING** Do **not** run your Power Unit without Hydraulic Fluid; you will damage it.

Approved Hydraulic Fluids are any general-purpose ISO-32, ISO-46, or ISO-68 hydraulic oil or approved automatic transmission fluids such as Dexron III, Dexron VI, Mercon V, Mercon LV, Shell Tellus S4 / S3 / S2, or any synthetic multi-vehicle automatic transmission fluid.

To fill the Hydraulic Fluid Reservoir:

1. Remove the Reservoir Cap from the top of the Hydraulic Fluid Reservoir and set it aside.

Take care to **keep contaminants out** of the Hydraulic Fluid Reservoir.

2. If the Hydraulic Fluid Reservoir is not full, use a clean funnel with a 60-micron filter to fill it with approved fluid.

The Reservoir holds approximately 3.5 gallons / 13.25 liters of Hydraulic Fluid.

3. When the Reservoir is filled, put the Reservoir Cap back on.

Important: Typically, the Platforms are up on the first Safety Lock at this point. Keep in mind that you will need to refill the Reservoir during the Operational Test. The Hydraulic Cylinders and Hydraulic Hoses will take up a considerable amount of fluid. If you have installed longer Hydraulic Hoses, then more than the specified typical amount will be required.

Perform an Operational Test

Before putting your Lift into normal operation, we recommend raising and lowering it two or three times. This will help the operator acquire experience operating the controls and help remove any residual air from the Hydraulic System (sometimes called “bleeding” the system).



Tip

Residual air in the Hydraulic System can cause the Lift to shake, move erratically, or squeak; this is normal when you first start using the Lift. It will soon stop doing this, as the Hydraulic System is self-bleeding.

The Drive-up Ramps do not need to be installed to test the Lift, nor do you need a Vehicle on it.

To test your Lift:

1. Check the area around and above the Lift for obstructions; move them away if you find any.
2. Press and hold the **Raise**.
The Platforms begin rising.
3. When the Platforms move past the first Safety Lock, release **Raise**.
The Platforms stop rising.
4. Press and hold **Safety Lock Release** and **Lower**.
The Platforms start lowering.
5. When the Platforms will stop when they return to the ground. Release **Safety Lock Release** and **Lower** buttons.
6. Wait for one minute.

 **WARNING** The Power Unit is not a constant duty motor; **it cannot be run continuously**. If you run it too long, it will overheat.

7. Repeat the process, this time raising the Lift to the top Safety Lock and then lowering it back down to the ground.
8. If the Lift is working without shaking, moving erratically, or squeaking, there is no need to repeat the procedure.

If the Lift is shaking, moving erratically, or squeaking, repeat the procedure one more time.

If you continue to have issues, refer to **Troubleshooting** for assistance.

Add the Ramp Extensions

The Ramp Extensions add length to the Platforms for use with Long Wheelbase Vehicles.

There are two Ramp Extensions of different lengths; the Short Ramp Extension (5601614) attaches at the Safety Lock end of the Platform, and the Long Ramp Extension (5601615) attaches at the Cylinder end of the Platform.

⚠ DANGER The maximum load capacity for the Ramp Extensions must **not** exceed 25% of the Lift's rated capacity (1,750 lbs. / 793 kg.). Overloading the Ramp Extensions can result in damage to the Lift or the Vehicle, cause serious bodily injury or death, and voids the warranty.

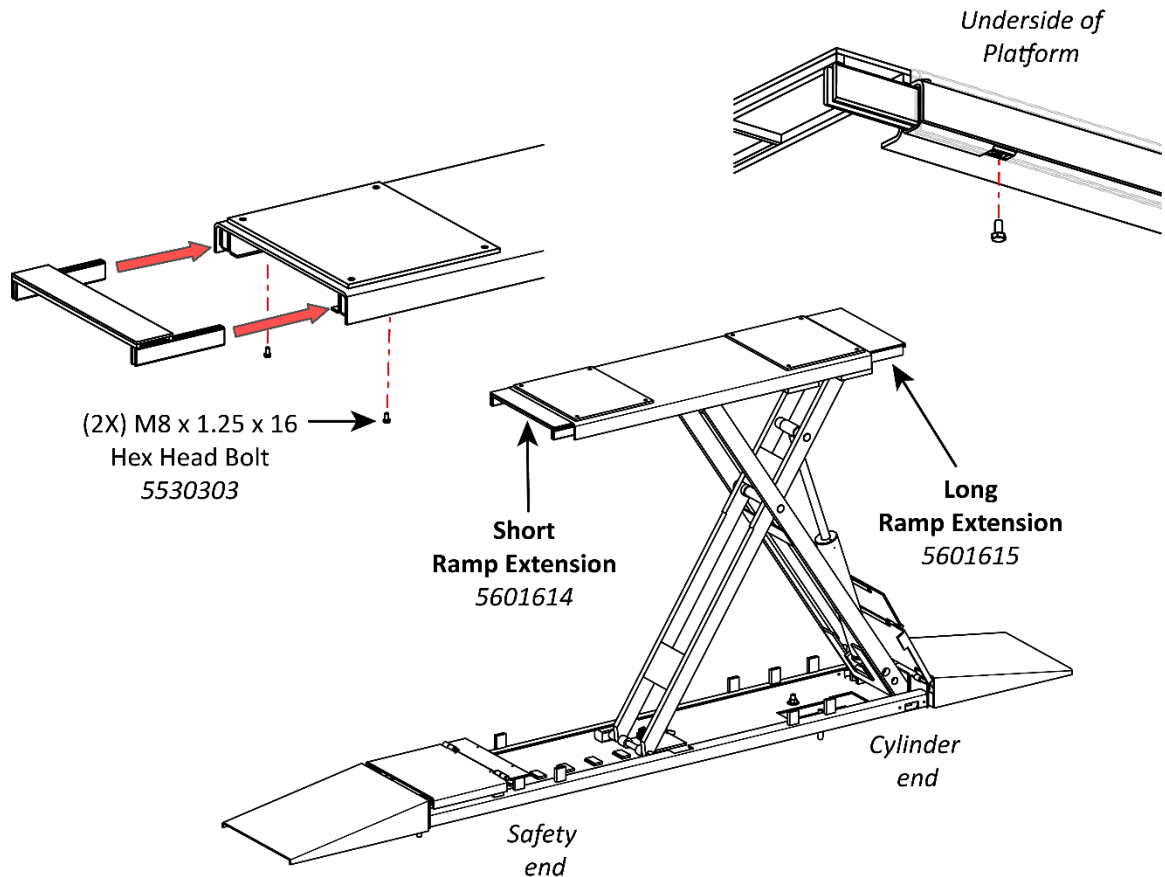

To add the Ramp Extensions:

1. Determine which Ramp Extension you want to start with first, then move to the corresponding end of the Platform.

The Short Ramp Extension attaches to the Safety Lock end, the Long Ramp Extension attaches to the Cylinder end of the Platform.

2. Slide the Ramp Extension into the slots near the end of the Platform, then secure on each side of the Ramp Extension from underneath using a M8 Hex Head Bolt.
3. Repeat the same steps for the other Ramp Extension on the other end of other Platform.

Add the Drive-up Ramps: SP-7XE only

The SP-7XE includes four Drive-up Ramps: two per Frame. The SP-7XEF does not include Drive-up Ramps, as it is flush mount.

You can attach the Drive-up Ramps in any configuration you want; they are all the same, so it does not matter where you put them.

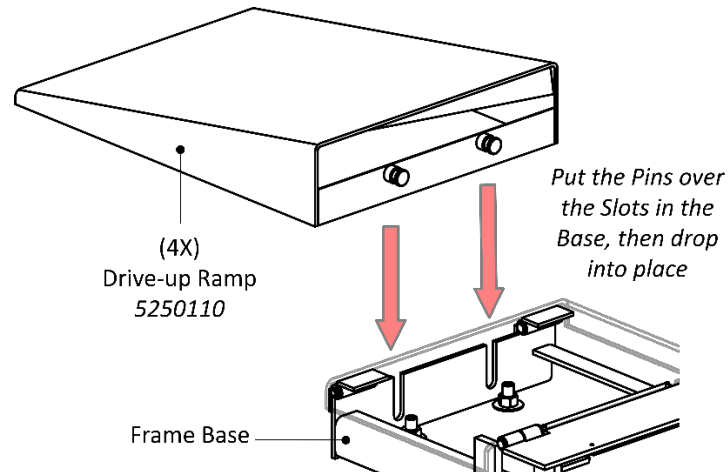

To put a Drive-up Ramp into position:

1. Put the pins over the slots in the Base, then move them down into the slots.
All four Ramps come with pins that fit into slots in the Base.
2. Double check to make sure they are correctly seated.

Final Checklist Before Operation

Make sure these things have been done before using your Lift:

3. Review the [Installation Checklist](#) to make sure all steps have been performed.
4. Make sure the Power Unit is receiving power from the power source.
5. Check the Hydraulic Fluid reservoir; it must be full of approved Hydraulic Fluid or automatic transmission fluid. **You can harm the motor by running it without enough fluid.**
6. Check the Hydraulic System for leaks. Verify all Hydraulic Hoses connections, Hydraulic Fittings, and Auxiliary Port Plugs on the Lift and Power Unit are tight.
7. Check to see that all Anchor Bolts are appropriately shimmed and correctly torqued.
8. Make sure that all Safety Locks are cleared and free.

Leave the Manual with the Owner/Operator

Make sure to leave the *Installation and Operation Manual* with the owner/operator so that it is available for anyone who needs to read it.



Operation

This section describes how to operate your Lift.

 **WARNING** Use care around the Lift. **When the Lift is moving, keep everyone at least 30 feet away from it.**

Lift Operation Safety

BendPak recommends referring to the ANSI/ALI ALIS Standard *Safety Requirements for Installation and Service* **available from ALI** for more information about safely installing, using, and servicing the Lift.

Before you raise or lower a Vehicle using your Lift, do the following:

- **Check the lift.** Check the Lift for any missing, heavily worn, or damaged parts. Do not operate the Lift if you find any issues; instead, take it out of service, then contact your dealer, email support@bendpak.com, visit bendpak.com/support, or call **(800) 253-2363**, select option 7 then 4.
- **Check the area.** Check the area around the Lift for obstructions; anything that might block the Lift. Do not forget to check **above** the Lift. If you find an obstruction, move it out of the way. Do not allow anyone within 30 feet of the Lift while it is in motion.
- **Check the operators.** Make sure everyone who is going to operate the Lift has been trained in its use, has read the labels on the unit, and has read the manual. Only the operator at the Console should be within 30 feet of the Lift when it is in motion.
- **Check for safety.** Make sure everyone who is going to be walking near the Lift is aware and takes appropriate safety measures. Only put Vehicles on the Lift. **When raising the Lift, do not leave it until it is engaged on a Safety Lock.** When lowering the Lift, do not leave it until it is fully lowered. Do not allow children to operate the Lift. Do not allow anyone under the influence of drugs or alcohol to operate the Lift.
- **Check the Vehicle.** Never exceed the Lift's weight rating. Do not allow people inside a Vehicle you are going to raise. Make sure the Vehicle is not overbalanced on either end. Make sure you know and use the manufacturer's recommended Lifting Points for the Vehicle. Never raise just one side, one corner, or one end of a Vehicle.

About Lifting Points and Lift Blocks

The raised Vehicle must be balanced on Lifting Blocks that ride on the Lift Platform.

 **WARNING** You **must** use all four Lift Blocks when raising a Vehicle. Never use just one, two, or three Lift Blocks to raise a Vehicle. The Vehicle will be unstable and could slip off the Lift, possibly damaging the Lift, damaging the Vehicle, and injuring anyone under it.

 **WARNING** Do not 'eyeball' the best location for the Adapters. **You must use the manufacturer's recommended Lifting Points.** If you do not, the Vehicle could become unstable and fall, which could damage the Vehicle, damage the Lift, or injure or even kill anyone under the Vehicle.

⚠ WARNING Many specialty or modified Vehicles or Vehicles with unusually short or long wheelbases cannot be on raised on a Frame Engaging Lift. Contact the Vehicle's manufacturer for Raising or Jacking guidance.

To balance a Vehicle on a full-rise frame-engaging Lift, the Lift Blocks must contact the Vehicle on the manufacturer's recommended Lifting Points. When you raise a Vehicle by its Lifting Points, the Vehicle is balanced.

NOTICE The manufacturer's recommended Lifting Points do not take into consideration any major changes that might have been made to the Vehicle. If the motor is removed, or there is a 5,000 pound / 2,268 kg weight in the trunk, the Vehicle's Lifting Points will not be the best balancing points.

Some vehicles may have the manufacturers' recommended Service Garage Lift Point locations identified by a triangle mark on the underside of the vehicle, reference SAE J2184- (Current Edition). On some vehicles, specific Lifting Points are indicated by a label located on the driver's side door jamb. Your best approach is to find the Vehicle in the *Vehicle Lifting Points for Frame Engaging Lifts* guide **available from ALI** (pg. 75) or contact the manufacturer of the Vehicle. This guide includes a page of safe lifting suggestions, which everyone who uses the Lift should read. The *Lifting it Right: A Safety Manual from the Automotive Lift Institute* is also **available from ALI** (pg. 75) and includes a wide variety of information about Lifts and how to use them safely

Typical Lifting Points:

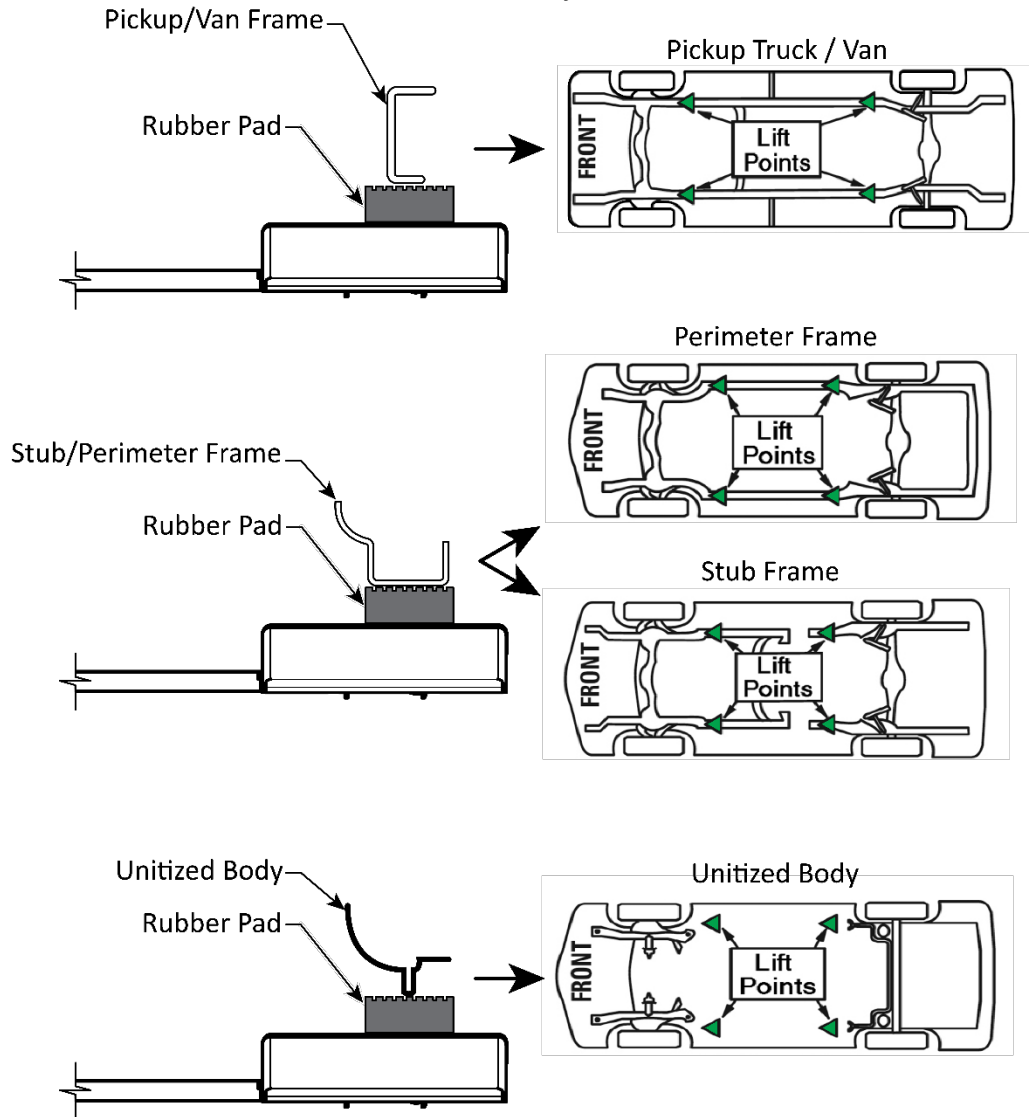

The Console

Operation of the Lift is controlled via the Console.

About Safety Locks

The Lift is supplied with multiple Safety Lock positions; they serve two important functions:

- Safety.** Safety Locks hold the SP-7XE/F Platforms in place. Once your Lift is engaged on the desired Safety Lock, the weight of the Vehicle holds the Platforms in place. If the power goes out, the Safety Locks still hold the Platforms, and anything on them, in place.

⚠ WARNING

Always leave your Lift on a Safety Lock or fully lowered. Although rare, it is possible

for Hydraulic Fluid in the Hydraulic Cylinders to leak, causing the Platforms to slowly lower. **Always leave your Lift either fully lowered or engaged on a Safety Lock. Never work under a vehicle unless the platform is fully engaged on a Safety Lock.**

- Adjustable height.** Having multiple Safety Locks means you can raise the Vehicle to just the right height for the work to be performed.

Additional Operation Safety Information

Read and understand the following instructions **before** operating your SP-7XE Series Lift:

- Never** exceed the rated capacity of the Lift, 7,000 lbs. / 3,175 kg.
- Never** exceed the maximum load of 3,500 lbs. / 1,587 kg per each Platform.
- Always** center the load evenly on the Platforms.
- Never** operate the Lift with any person or equipment under the Lift.
- Always** use the Lift in the proper manner. Never use the Lift Adapters in any way other than what is approved by the manufacturer.
- Always** keep a clear visual line of sight on the Lift and Vehicle.
- Always** verify the Vehicle is centered and stable prior to operating the Lift Controls.
- Always** verify the Safety Locks are engaged before working on or near any Vehicle.
- Never** leave the Lift in an elevated position unless both Safety Locks are securely engaged and resting on a Safety Lock at the same height.

⚠ WARNING

FAILURE TO READ, UNDERSTAND, AND FOLLOW INSTRUCTIONS AND WARNINGS MAY RESULT IN SERIOUS PERSONAL INJURY AND/OR PROPERTY DAMAGE.

✓ Never exceed rated capacity of lift.

✓ DO NOT operate lift if any component is found to be defective or worn.

✓ Never operate lift with any person or equipment below.

✓ Always ensure load is centered and stable prior to operating controls.

✓ Always verify safety locks are engaged before working on or near vehicle.

✓ Never leave lift in an elevated position unless all safety locks are engaged.

✓ Do not permit electric motor to get wet! Mo or damage caused by dampness is not covered under warranty.

OPERATING INSTRUCTIONS

Model	Max. Lifting Capacity	TO RAISE LIFT	TO LOWER LIFT
MDS-SEP	6,000 lbs. / 2,722 kg	1. Position vehicle's center of gravity over center of lifting platform.	1. Before lowering vehicle, be sure all personnel, tools and equipment are clear of lift and surrounding area.
MDS-ILPF		2. Do not pull up cable and wire steel block to hold vehicle in position.	2. Raise lift by pressing RAISE button. Elevate lift at least two inches to allow adequate clearance for locks to slide.
MDS-SEXT		3. Before raising vehicle, be sure all personnel are clear of lift and surrounding area. Pay special attention to overhead clearance.	3. Press and HOLD SAFETY LOCK RELEASE button.
MDS-SEXTF	7,000 lbs. / 3,175 kg	4. Raise lift to desired height by pressing RAISE button.	4. Lower vehicle by pressing LOWER button until lift has descended completely.
SP-7XL		5. Monitor visual contact with vehicle and surrounding area at all times while raising or lowering lift.	5. When lowering lift, MAKE SURE that all personnel and objects are kept clear of lift and surrounding area.
SP-7XLF	8,000 lbs. / 4,082 kg	6. STOP IMMEDIATELY if load shifts or becomes unlevel.	6. ALWAYS keep visual line of sight on lift at ALL TIMES.
PROBOLT		7. After vehicle is raised to desired height, lower lift onto the second safety lock.	7. ALWAYS make sure that ALL LOCKS are disengaged. If one of the locks is not completely engaged, disengage lift and/or vehicle until lift is fully lowered to ground.
PROBOLTF		8. ALWAYS ENSURE ALL SAFETY LOCKS ARE ENGAGED before entering work area.	



SAFETY FIRST

RAISE

LIFT OPERATION

LOWER

BP BendPak

TEL: 805-953-9970 • www.bendpak.com
1802 Eisenhower Dr. • Brea, CA 92606
ENGINEERED BY BENDPAK USA • MADE IN CHINA

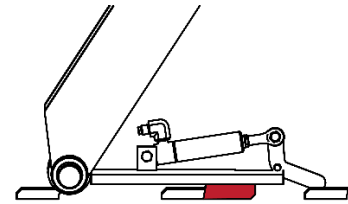

Locked

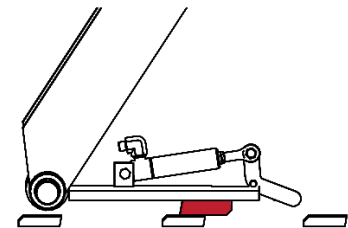

Passing

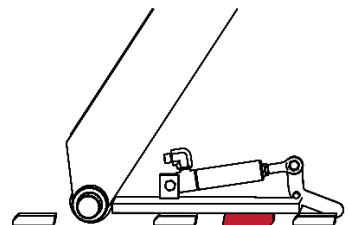

Unlocked

- **Never** leave the Controls while the Lift is still in motion.
- Do **not** rock the Vehicle while on the Lift or remove any heavy component from Vehicle that may cause excessive weight shift.
- Do **not** permit the Power Unit to become wet. The motor can be damaged and water damage is not covered under the product warranty.
- Always allow a minimum of 2 seconds delay between motor starts. Failure to comply may cause Switch and/or Motor burnout. This could cause serious damage to the equipment.
- If any part of the Vehicle's Lifting Points are **not** completely over the Platform, carefully drive the Vehicle back off the Lift and then drive it back on to reposition it, making sure to keep the Wheels in the middle of the Platforms.

⚠ WARNING You **must** use the Vehicle manufacturer's recommended Lifting Points. If you fail to do so, the Vehicle may become unstable and fall off the Pads and/or the Lift which could damage the Vehicle, the Lift, or injure or kill anyone under the Vehicle.

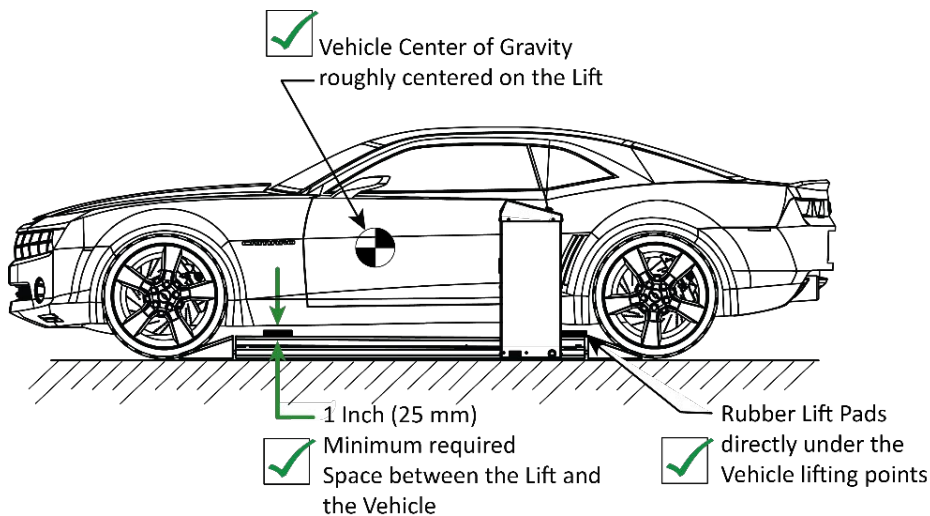

⚠ WARNING Before raising a Vehicle, verify there is at least 1 inch / 25 mm of clearance between the Lift Pads and the Vehicle. The Lift cannot raise a full load from a completely flat starting position, and attempting to lift in this manner will damage the Lift and could injure persons nearby.

⚠ WARNING Do **not** lower a Vehicle all the way to the floor with the wheels removed. **Failure to comply with these instructions will void the product warranty.** BendPak will assume no liability for loss or damage of any kind, expressed or implied resulting from improper installation or use of this product.

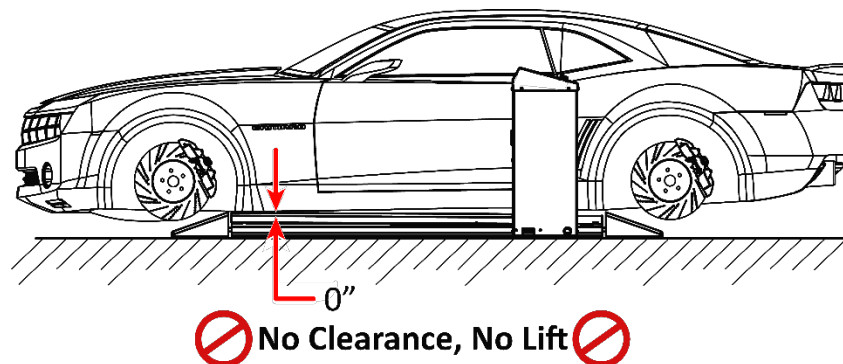

⚠ WARNING Never raise a Vehicle with the center of Gravity shifted off the Platforms.

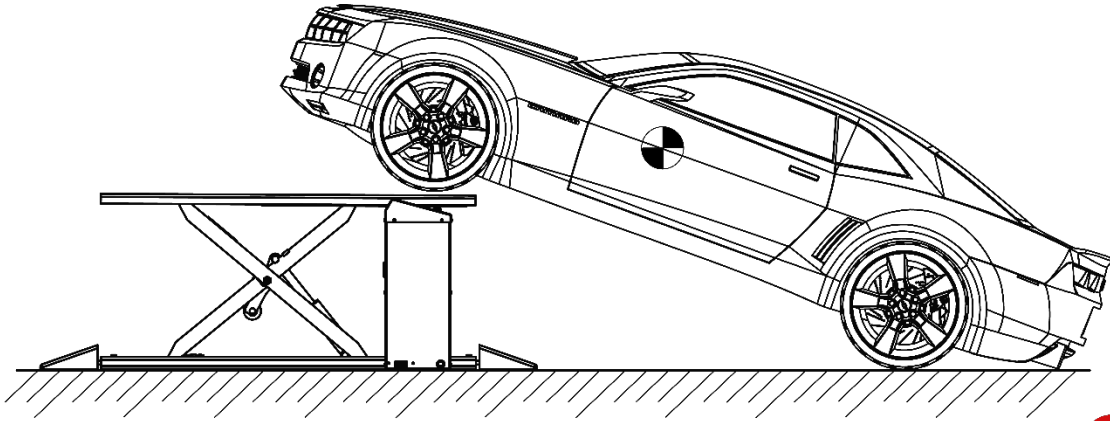

⊘ Never lift a Vehicle with the Center of Gravity shifted off the Lift Platforms. ⊘

Raising a Vehicle

This section describes how to position a Vehicle on the Lift and raise it.

⚠ WARNING Always use care when you are around the Lift. When it is in a lowered position, be careful not to trip over it. When it is raised, be careful not to bang into a Drive-up Ramp or a Platform. **When the Lift is moving, keep all people, animals, and objects at least 30 feet away from it.**

To raise a Vehicle:

1. Check the items listed in **Lift Operation Safety**.
If you find any issues, resolve them **before** raising the Vehicle.
2. Make sure both Platforms are on the ground.
3. Drive the Vehicle over the Platforms and center it on the Platforms.
4. Put the Vehicle in park, put on the parking brake, and turn off the Vehicle.
If the Vehicle is a manual transmission, put it into first gear before turning it off.
5. Walk around the Vehicle and make sure there are no obstructions or any other issues that will interfere with the raising of the Platforms.
6. At the Console, press and hold the **Raise** button.
7. Watch the Vehicle and the Platforms as they rise.
If the Lift becomes unstable or the Vehicle starts moving, release the **Raise** button immediately.

⚠ WARNING Do not raise the Lift any farther until you are certain the Vehicle on the Lift is both stable and balanced. If the Vehicle is not stable and balanced, it could fall, which could damage the Vehicle, damage the Lift, or injure or kill anyone under the Lift.

8. When the Platforms are just past the desired height, release the **Raise** button.
9. Press the **Lower** button briefly to move the Platforms back down, which engages them on the most recently passed Safety Lock.

If you do not go far enough past the desired Safety Lock and then lower the Platforms, you may miss engaging on the Safety Lock. This means that if you continue to hold the **Lower** button, the Platforms will go all the way back to the ground.

If you miss the desired Safety Lock, press and hold **Raise** again and go somewhat farther past the desired Safety Lock. Release **Raise**, then hold **Lower** again to lower the Platforms onto the desired Safety Lock.

Lowering a Vehicle

This section describes how to lower a Vehicle from a raised position.

To lower a vehicle:

1. Check the items listed in Lift Operation Safety.

If you find any issues, resolve them before lowering the vehicle.

2. At the Console, press and hold the **Raise** button for a second or two.

This moves the Platforms off the engaged Safety Lock.

3. Press and hold **Safety Lock Release**, then press and hold **Lower**.

If you do not press and hold the Safety Lock Release, the Lift will engage on the next Safety Lock.

 **WARNING** Always verify both Safety Locks disengage when the Safety Lock Release button is pressed. If one of the Safety Locks inadvertently engages on descent, the Lift and Vehicle may become unbalanced and can cause severe injury or death.

4. Carefully drive the Vehicle off the Platforms.

Optional Lift Arm Kit

If you purchased the optional Lift Arm Kit, this section describes how to use it.

The Kit is supplied with four Lift Arms. Hook them on the outside edge of a Platform, and install the desired Pads, drive the Vehicle over the Lift, and then position the Pads under the manufacturer's recommended Lifting Points for the Vehicle being raised.

⚠ DANGER The maximum Vehicle weight allowed using all four Lift Arms (which must always be used four at a time) is 4,800 lb. / 2,177 kg. Do **not** raise a Vehicle that weighs more than this; if you do, you could damage the Lift or the Vehicle, you put at risk everyone near the Lift, and you void your warranty. Each Lift Arm is rated for a **maximum** of 1,200 lb. / 544 kg; **never exceed this weight** on one Lift Arm.

Position the Pads by sliding the Lift Arms along the outside edge of the Platform.

Each Lift Arm can be fitted with either a Short Pad or a Tall Pad/Adapter/Base combination, all of which come with the Lift Arm Kit.

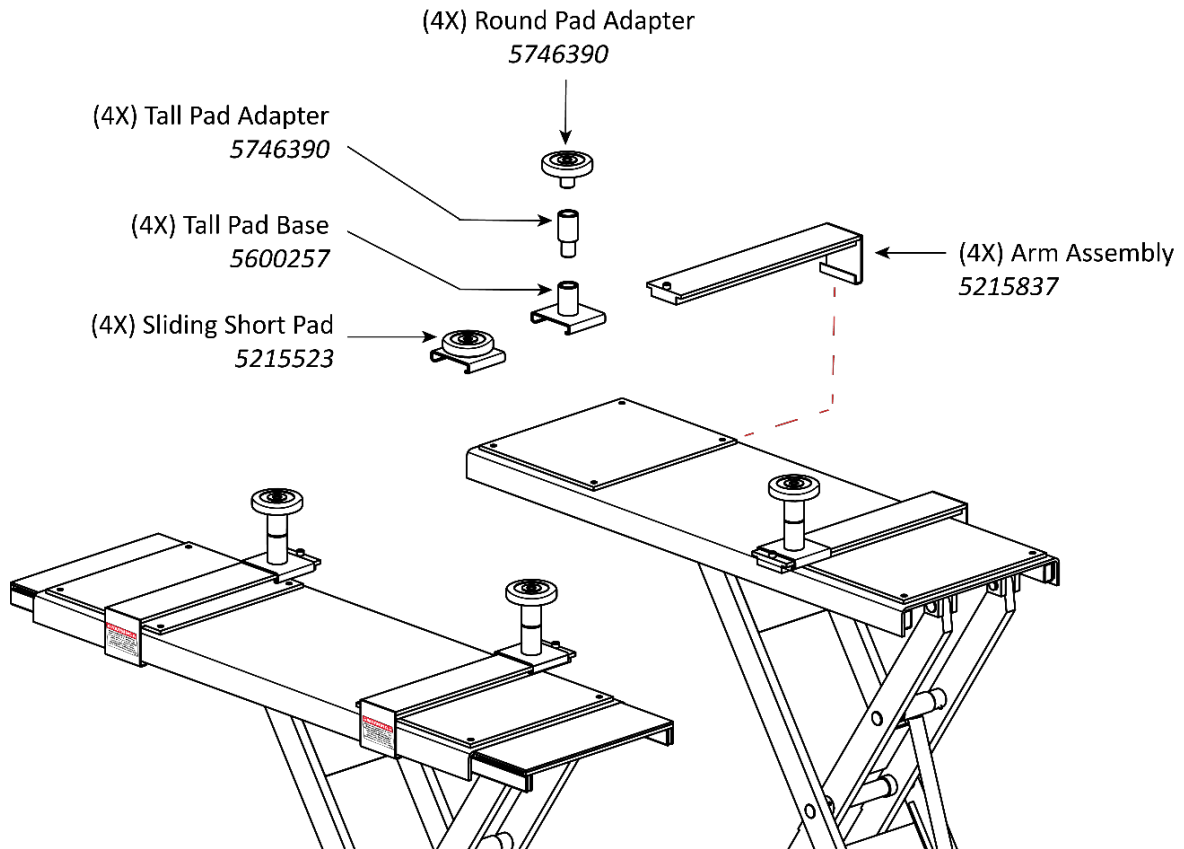

Important: When raising Vehicles with **body-on-frame** construction (compared to **unibody** construction), BendPak recommends purchasing 35 mm Frame Cradle Pads for safer lifting. These are available on the [BendPak website in the Car Lift Accessories section](#). Make sure to order the **35 mm Pin Diameter** option.

The Frame Cradle Pads replace the Tall Pad in the Tall Pad/Adapter/Base combination.

To switch between Short Pads and the Tall Pad/Adapter/Base, remove the Lock Screw on the end of the Lift Arm, remove the current Pad, slide on the desired Pad, and then replace the Lock Screw.

If you are using the Tall Pad/Adapter/Base combination, you can use it with or without the Adapter.

Optional Extended Drive-Up Ramp Kit

Extended Drive-Up Ramps (5210306) are available for the SP-7XE. The extended Ramps are 12.87 in. / 327 mm longer and a drop-in replacement for the standard ramps delivered with the SP-7XE.

The Extended Drive-Up Ramp Kit includes four Ramps.

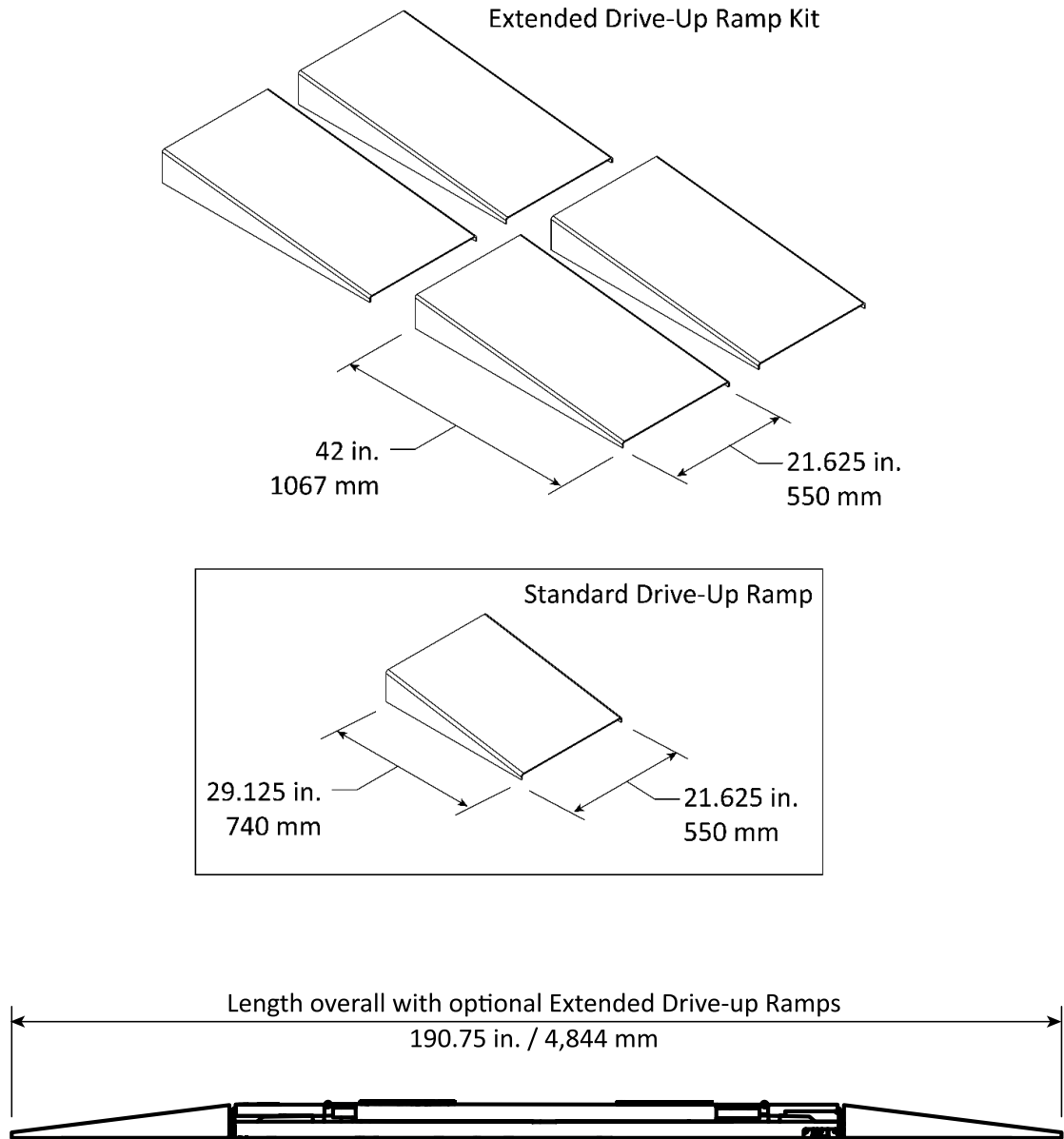

Visit the Web Technical support and service is available from your dealer, on the Web at bendpak.com, by email at support@bendpak.com, or by phone at **(800) 253-2363**, option 7, then 5.

Maintenance

⚠ DANGER Before performing any maintenance, make sure the Lift is completely disconnected from power and **cannot** be re-energized until all maintenance is complete. BendPak strongly recommends using your Power Disconnect Switch during maintenance.

To maintain your Lift:

- **Daily:** Keep the Lift clean. Wipe up any oil spills, clean and remove dirt and debris.
- **Daily:** Make a visual inspection of all moving parts and check for damage or excessive wear. If you find any damaged or worn parts, take the Lift out of service until they are replaced.
- **Daily:** Make sure the Safety Locks are in good operating condition. If you find that the Safety Locks are damaged or excessively worn, take the Lift out of service until they are replaced. **Do not use your Lift if the Safety Locks are damaged or excessively worn.**
- **Weekly:** Check all controls to verify they are functioning normally.
- **Weekly:** Check all labels on the unit. Replace them if they are illegible or missing.
- **Monthly:** Lubricate all slide block travel zones and scissor pivot points with white lithium grease or equal.
- **Monthly:** Check the Power Unit's Hydraulic Fluid levels. Refill if low.

⚠ WARNING **Never** open the back of the Console to access the Power Unit. Severe injury and component damage are possible. Always access the Power Unit through the Console's front panel. The power unit is heavy, and the back panel is not designed to hold the power unit without support from the Console's side panels.

- **Monthly:** If the Lift has experienced little or no use during the month, run the Lift up and down several times. This action will wet the Cylinder Seals and improve their long-term elasticity.
- **Every two months:** Check all Anchor Bolts to make sure they are tight. If not, tighten them.

⚠ WARNING Do not operate your Lift if you find issues; instead, take the lift out of service, then contact your dealer, email support@bendpak.com, visit bendpak.com/support, or call **(800) 253-2363**, select option 7 then 4

Disposing of Used Hydraulic Fluid

Used Hydraulic Fluid cannot be disposed of by dropping it into the trash or dumping into the street. Hydraulic Fluid has toxic ingredients that are harmful to the environment. Either recycle the Hydraulic Fluid or drop it off at a hazardous waste collection facility. Dirty or contaminated fluid must be treated as hazardous waste. Rags and/or granular absorbents that have soaked up Hydraulic Fluid should be treated like hazardous waste and be disposed of at a hazardous waste collection facility.

To find an appropriate facility:

- Local automotive parts stores, auto care facilities, or automobile dealerships may accept fluid for recycling or, in some cases, for disposal. Contact them for more information.
- Cities, counties, and states often support both recycling facilities and hazardous waste collection facilities. Contact them to see if and where they have these programs.

If you are unable to find an appropriate facility, the website earth911.com has resources that may be of help.

SP-7XE and SP-7XEF Lift Disposal - End of Service Life

Once your Lift has reached the end of its service life it must be disposed of properly. Metal recyclers will be able to advise on methods and costs to remove the Lift and will *reuse* the materials, diverting them from landfills. The best option is to contact a metal recycling center and discuss the size and weight of the Lift to determine if the facility can deconstruct and recover the usable components and metals.

The Hydraulic Cylinders, Hoses, Fittings, and the Power Unit itself must be disposed of in accordance with current national, state, and local regulations governing the use and disposal of hazardous materials. These components and any used Hydraulic Fluid *must not* be disposed of by dropping it into the trash or dumping it into the street. The Hydraulic Fluid contains toxic ingredients that are harmful to the environment.

These components and the Hydraulic Fluid are required to be recycled or must be delivered to a hazardous waste collection facility.

If you have substantial amounts of Hydraulic Fluid, consider contacting a commercial waste disposal company. In all cases, the best approach is to find an appropriate facility and contact them — in advance — to ask them: what kinds of fluids and materials they accept, what kind of containers it must be in, what hours they are open, their location, and any other information specific to their facility.

If you are unable to find an appropriate facility, the website [earth911.com](https://www.earth911.com) has resources that may be of help.

Troubleshooting

This section describes how to troubleshoot your Lift.

Note: If your Lift is not functioning correctly, you must take it out of service until it is fixed.

Important: Qualified personnel must perform all repair work.

Issue	Action to Take
Platforms move erratically or squeak when in use.	Move the Platforms up and down a few times, with a break between each; there could be residual air in the Hydraulic System. The Hydraulic Cylinders are self-bleeding.
Platforms are stuck in the up position and will not lower with the Vehicle on the Lift.	Verify the Power Unit is being supplied electrical power and that none of the Hydraulic Hoses are pinched or leaking. Verify there is sufficient Hydraulic Fluid in the Reservoir on the Power Unit. Contact BendPak Service bendpak.com/support , or call (800) 253-2363 , option 7 then 4.
Hydraulic Fluid is old or dirty.	Replace the dirty fluid with clean, approved Hydraulic Fluids, such as Dexron III, Dexron VI, Mercon V, Mercon LV, Shell Tellus S4 / S3 / S2, or comparable.
Platforms make odd noises when in use.	Lubricate hinge points using white lithium grease. Lubricate the Platforms where the Slide Blocks travel using White Lithium Grease.
Platforms are slowly lowering on their own.	Make sure both Platforms are on Safety Locks (if not, Hydraulic Fluid is being pushed back into the reservoir, lowering the Platforms). <i>Only leave the Lift either fully lowered or engaged on a Safety Lock.</i>

If you continue to have problems with your Lift, contact your dealer, visit bendpak.com/support, email support@bendpak.com, or call **(800) 253-2363**, option 7, then 4.

Vehicles with No Tires – Fully Lowered

When the SP-7XE Series Lift is completely flat with a vehicle directly on the Platforms, there is no room to develop any mechanical upward force. The weight on the Lift must be reduced by at least half or raise the Vehicle off the Lift Platform or Lift Pads in some other manner.

Methods that have resolved this issue include:

- Use a floor jack to raise the Vehicle from 4 to 6 inches.
- Using lifting equipment to raise the Vehicle. If you are still unable to raise your Vehicle, contact BendPak Technical Support for assistance.

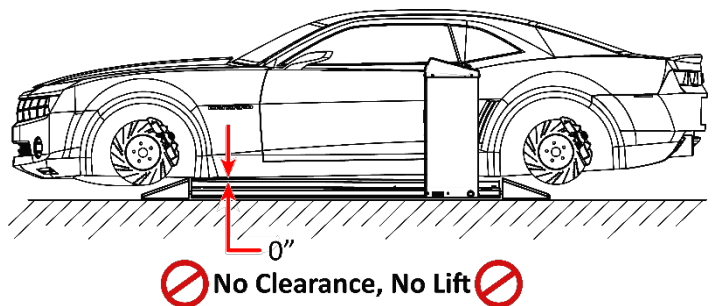

Disposing of Used Hydraulic Fluid

Used Hydraulic Fluid cannot be disposed of by dropping it into the trash or dumping into the street. Hydraulic Fluid has toxic ingredients that are harmful to the environment. Either recycle the Hydraulic Fluid or drop it off at a hazardous waste collection facility. Dirty or contaminated fluid must be treated as hazardous waste. Rags and/or granular absorbents that have soaked up Hydraulic Fluid should be treated like hazardous waste and be disposed of at a hazardous waste collection facility.

To find an appropriate facility:

- Local automotive parts stores, auto care facilities, or automobile dealerships may accept fluid for recycling or, in some cases, for disposal. Contact them for more information.
- Cities, counties, and states often support both recycling facilities and hazardous waste collection facilities. Contact them to see if and where they have these programs.

If you are unable to find an appropriate facility, the website [earth911.com](https://www.earth911.com) has resources that may be of help.

SP-7XE and SP-7XEF Lift Disposal - End of Service Life

Once your Lift has reached the end of its service life it must be disposed of properly. Metal recyclers will be able to advise on methods and costs to remove the Lift and will *reuse* the materials, diverting them from landfills. The best option is to contact a metal recycling center and discuss the size and weight of the Lift to determine if the facility can deconstruct and recover the usable components and metals.

The Hydraulic Cylinders, Hoses, Fittings, and the Power Unit itself must be disposed of in accordance with current national, state, and local regulations governing the use and disposal of hazardous materials. These components and any used Hydraulic Fluid *must not* be disposed of by dropping it into the trash or dumping it into the street. The Hydraulic Fluid contains toxic ingredients that are harmful to the environment.

These components and the Hydraulic Fluid are required to be recycled or must be delivered to a hazardous waste collection facility.

If you have substantial amounts of Hydraulic Fluid, consider contacting a commercial waste disposal company. In all cases, the best approach is to find an appropriate facility and contact them — in advance — to ask them: what kinds of fluids and materials they accept, what kind of containers it must be in, what hours they are open, their location, and any other information specific to their facility.

If you are unable to find an appropriate facility, the website [earth911.com](https://www.earth911.com) has resources that may be of help.

Wiring Diagrams



WARNING

All electrical work must be performed by a licensed Electrician in accordance with all applicable local and national electrical codes. **Damage caused by improper electrical installation may void your warranty.**

5585442

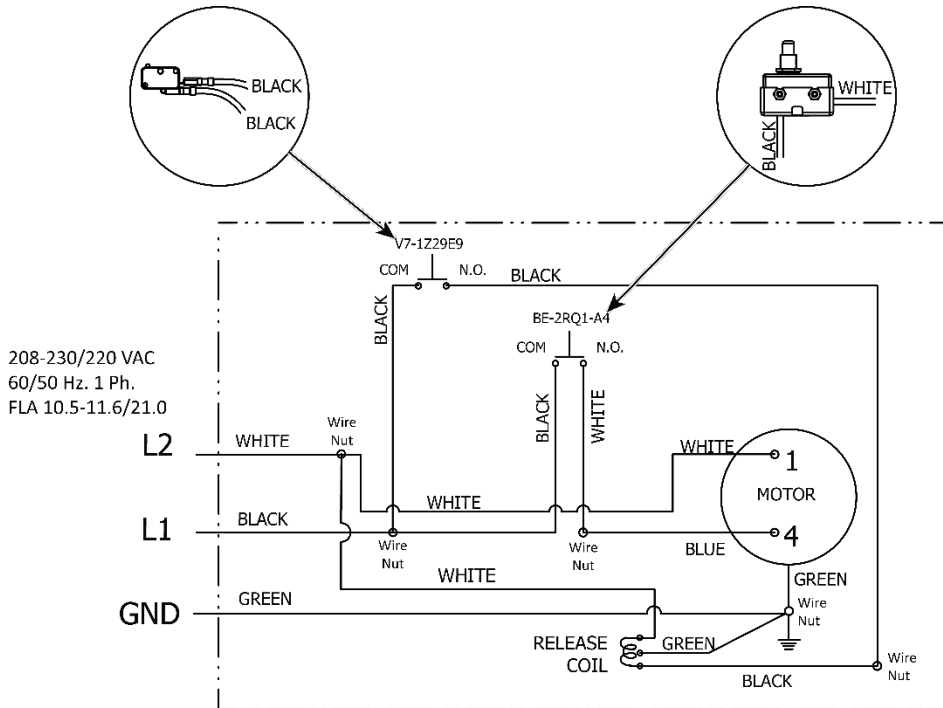

Electrical Schematic

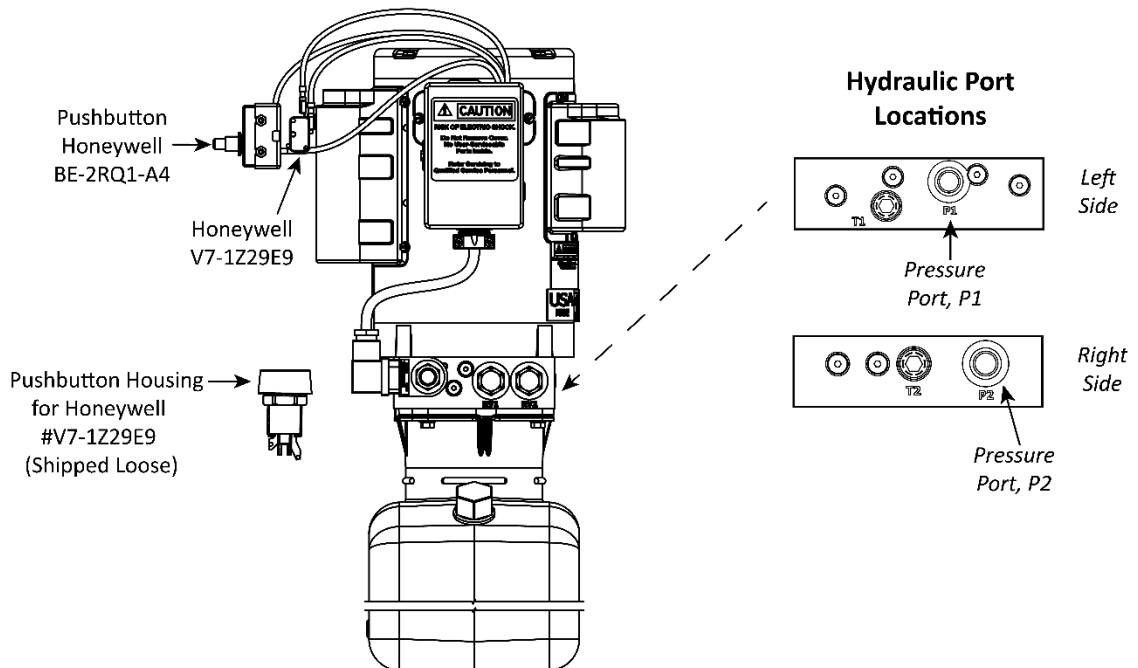

⚠ WARNING

All electrical work must be performed by a licensed Electrician in accordance with all applicable local and national electrical codes. **Damage caused by improper electrical installation may void your warranty.**

5585022

208-240VAC
1 Ph., 50/60Hz. 3HP

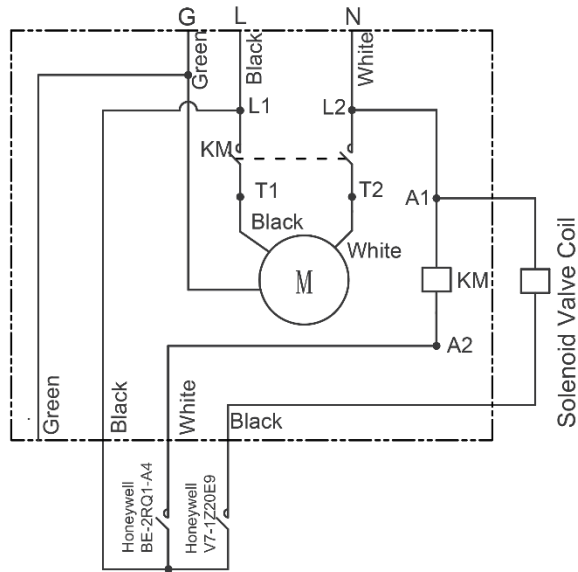

Electrical Schematic

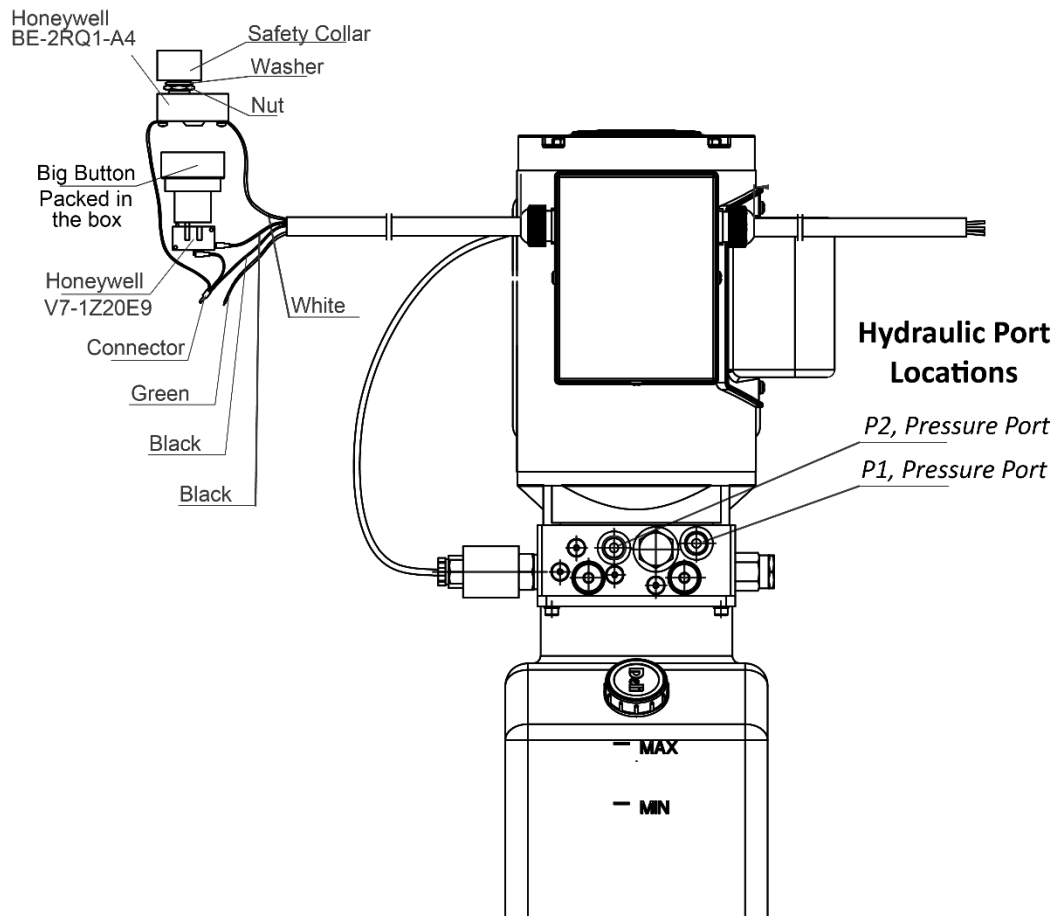

Labels

A

⚠ WARNING

FAILURE TO READ, UNDERSTAND, AND FOLLOW INSTRUCTIONS AND WARNINGS MAY RESULT IN SERIOUS PERSONAL INJURY AND/OR PROPERTY DAMAGE.

- ✓ Never exceed rated capacity or lift.
- ✓ DO NOT operate lift if any component is found to be defective or worn.
- ✓ Never operate lift with a person or equipment inside.
- ✓ Always ensure load is centered and stable prior to operating scissor.
- ✓ Always verify safety codes are engaged when working on or near vehicle.
- ✓ Never raise lift in a restricted position unless all safety locks are engaged.
- ✓ Do not permit weights inside to get over height damage caused by emergency lift not lowered under warranty.

OPERATING INSTRUCTIONS

Model	Max. Lifting Capacity
MDS-5L	6,000 lbs. / 2,722 kg
MDS-5LF	
MDS-5EXT	
MDS-6EXT	7,000 lbs. / 3,175 kg
MDS-6EXTF	
SP-7XL	9,000 lbs. / 4,082 kg
SP-7XLF	
PRODUCT	
PRODUCT	

TO RAISE LIFT

- Position vehicle on level or gently sloped surface of lifting platform.
- Set parking brake and use wheel chock on both vehicle front wheels.
- Before raising vehicle, be sure all persons are out of lift and surrounding area. Pay close attention to overhead clearances.
- Follow lift's descent handle, depressing RAISE button.
- Maximize crane capacity with full lift and a handling area at different lifting or lowering lift.

STOP IMMEDIATELY if load shifts or becomes unbalanced.

At all vehicle in raised to desired height, lower all four vehicle safety locks.

ALWAYS ENGAGE ALL SAFETY LOCKS ARE ENGAGED before or during work area.

TO LOWER LIFT

- Before lowering vehicle, be sure all personnel, tools and equipment are clear of crane, into, and around crane.
- Lower lift by pressing RAISE > then, Release lift > push the release to allow 25% lift and lower the lift to 25%.
- Press and HOLD SAFETY LOCK RELEASE button.
- Lower on lift by pressing LOWER button until lift has descended completely.
- When lowering lift, **MAKE SURE** that all personnel and objects are not in the lift's surrounding area.
- ALWAYS** keep a visual line of sight on lift **AT ALL TIMES**.
- ALWAYS** make sure that ALL LOCKS are disengaged if one of the locks is damaged by a person or object, or if one of the lifts is damaged during the time of work.

SAFETY FIRST

RAISE

LIFT OPERATION

LOWER

SAFETY LOCK RELEASE

BP BendPak

TEL: 800-623-9970 • www.bendpak.com
 1045 Lummiswood Dr. • Santa Paula, CA 91360
 ENGINEERED BY BENDPAK USA • MADE IN CHINA

B



C

CAUTION!

Maximum load on scissor lifts should **NOT** exceed 3,500 pounds per side. Always center the load evenly. **NEVER** attempt to work on or near a vehicle when it is raised on the scissors unless the safety latches are engaged on each scissor unit.

P/N 5905524

D

BP BendPak Santa Paula, CA USA
www.bendpak.com

MODEL NUMBER _____

DESCRIPTION _____

LIFT CAPACITY _____ DATE CODE _____

VOLTAGE	SERIAL NUMBER
<input type="checkbox"/> 110-120V, 50-60 Hz, 1 Ph	_____
<input type="checkbox"/> 208-240V, 50-60 Hz, 1 Ph	
<input type="checkbox"/> 380-415V, 50-60 Hz, 3 Ph	
<input type="checkbox"/> 208-440V, 50-60 Hz, 3 Ph	
UPC _____	

⚠ DANGER!
Disconnect Power Before Servicing

ERC

MADE IN CHINA WARRANTY VOID IF DATA PLATE IS REMOVED P/N 5905561

E

BP BendPak SANTA PAULA, CA USA
WWW.BENDPAK.COM

LIFT TYPE: SURFACE MOUNT CAP: MED/HVY DTY MFG. BPK SEE DATA PLATE FOR PRODUCT DETAILS

POWER: ELECTRIC/HYDRAULIC INSTALLATION - SEE OWNERS GUIDE OR CONTACT FACTORY

SAFETY INSTRUCTIONS: IF ATTACHMENTS, ACCESSORIES OR CONFIGURATION, MODIFYING COMPONENTS THAT ARE LOCATED IN THE LOAD PATH, AFFECT OPERATION OF THE LIFT, AFFECT THE LIFT ELECTRICAL LISTING OR AFFECT INTENDED VEHICLE ACCOMMODATION ARE USED ON THIS LIFT AND IF THEY ARE NOT CERTIFIED FOR USE ON THIS LIFT, THEN THE CERTIFICATION OF THIS LIFT SHALL BECOME NULL AND VOID. CONTACT THE PARTICIPANT FOR INFORMATION PERTAINING TO CERTIFIED ATTACHMENTS, ACCESSORIES OR CONFIGURATION/MODIFYING COMPONENTS.

BENDPAK LIFTS ARE SUPPLIED WITH CONCRETE FASTENERS MEETING THE CRITERIA AS PRESCRIBED BY ASTM E188 - 08(2009). LIFT BUYERS ARE RESPONSIBLE FOR ANY SPECIAL, REGIONAL, STRUCTURAL AND/OR SEISMIC ANCHORING REQUIREMENTS SPECIFIED BY ANY OTHER AGENCIES AND/OR CODES SUCH AS THE INTERNATIONAL BUILDING CODE (IBC) AND/OR INTERNATIONAL BUILDING CODE (IBC).

THE MANUFACTURE, USE, SALE OR IMPORT OF THIS PRODUCT MAY BE SUBJECT TO ONE OR MORE UNITED STATES PATENTS, OR PENDING APPLICATIONS, OWNED BY BENDPAK, INC.

DO NOT REMOVE ENGINEERED BY BENDPAK INC. USA MADE IN CHINA

F

⚠ WARNING

SLIPPERY WHEN WET OR ICY

Use caution when driving onto wet or icy drive-up ramps and platforms. **DO NOT** walk on lift surfaces that are wet or icy.

⚠ AVERTISSEMENT

GLISSANT LORSQU'IL EST MOUILLÉ OU GLACÉ

Soyez prudent lorsque vous conduisez sur des rampes d'accès mouillées ou verglacées et les plateformes. **NE PAS** marcher sur des surfaces de levage humides ou glacées.

G



CALIFORNIA PROPOSITION 65

⚠ WARNING ⚠

WARNING! This product can expose you to chemicals including styrene and vinyl chloride which are on the list of over 900 chemicals identified by the State of California to cause cancer, birth defects or reproductive harm. **ALWAYS** use this product in accordance with the manufacturer's instructions.

For more information, go to www.p65warnings.ca.gov. P/N 5905775

**Prop 65 on packaging*

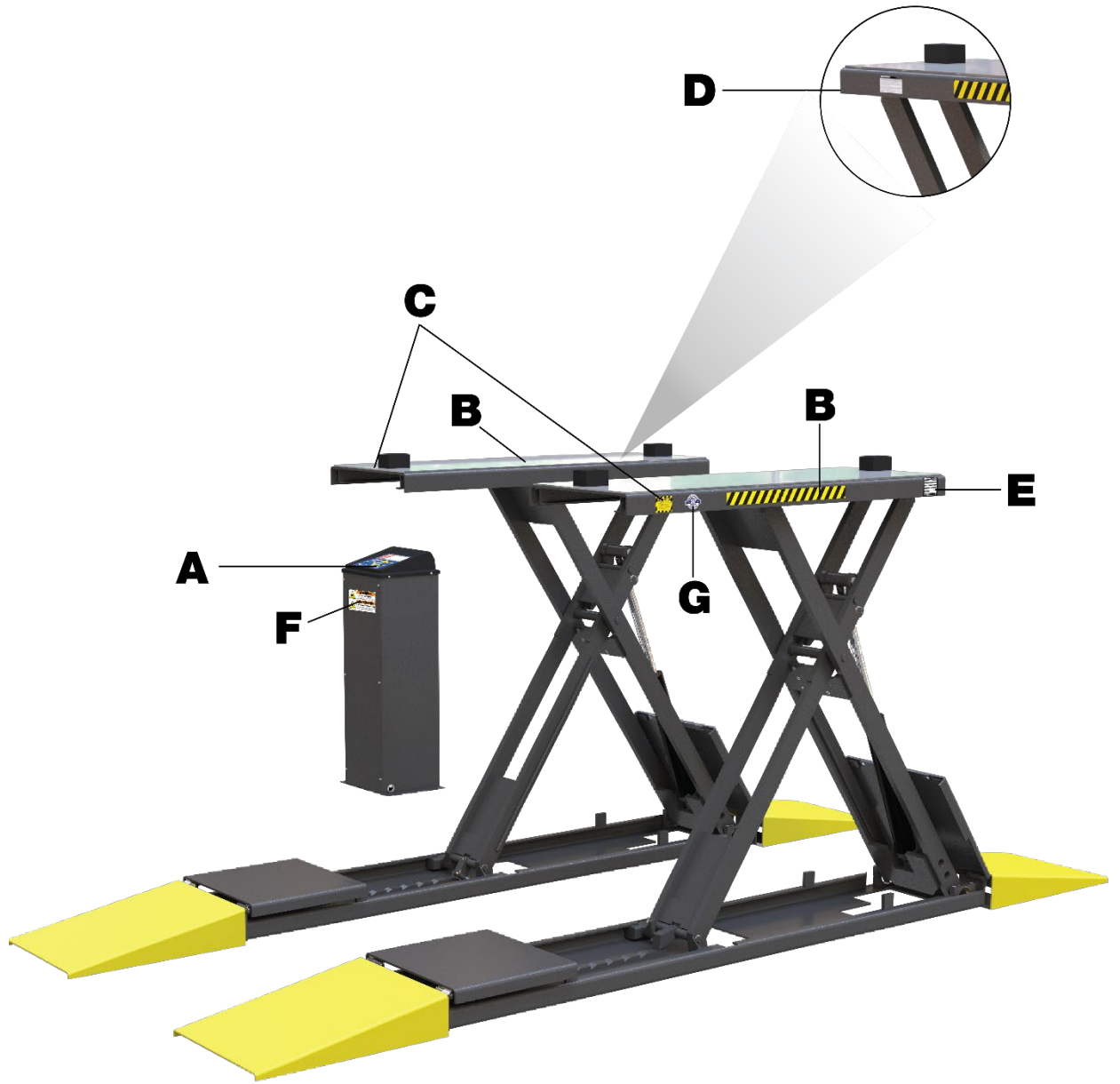

Parts Diagrams

ITEM NO	PART NUMBER	DESCRIPTION	QTY	REV
1	5216132	SP-7XE RAMP ASSEMBLY	2	C
2	5250110	SP-7XE PARTS BOX	1	G
3	5600263	SP-7XE DRIVE UP RAMP WELDMENT	4	C
4	5215781	TALL POWER UNIT CONSOLE ASSEMBLY	1	F
5	5601099	MDS-6/SP-7XE INNER FLOOR TROUGH WELDMENT	1	D
6	5601098	SP-7XE/MDS-6EXT/LP OUTER FLOOR TROUGH WELDMENT	1	C
7	5210257	SP-7XE RAMP EXTENSION KIT	2	A

DO NOT SCALE DRAWINGS				
DRAWN	TM	03/30/2022	845 LEWIS WOOD DR SANTA PAULA, CA 95890	
CHECKED			TITLE: SP-7XE PRODUCTION LIFT VER B	
DIMENSIONS ARE IN MM			THIRD ANGLE PROJECTION	SIZE: DWG. NO. 5260681 REV C
			PROPRIETARY AND CONFIDENTIAL ALL INFORMATION CONTAINED HEREIN IS THE PROPERTY OF BENDPAK INC. AND IS TO BE KEPT IN STRICT CONFIDENCE. ANY UNAUTHORIZED DISCLOSURE OR REPRODUCTION OF THIS INFORMATION IS STRICTLY PROHIBITED.	
			SCALE: 1:28	SHEET 1 OF 3

Full Rise: 70.473in (1790.0mm) height, 3.937in (100.0mm) offset, 7.500in (190.5mm) offset, 62.598 MIN - 74.035in MAX (1590.0 MIN - 1880.5mm MAX) width.

Top Lock: 69.792in (1772.7mm) height.

Lowest Lock: 24.513in (622.6mm) height.

Fully Lowered: 6.351in (161.3mm) height.

TITLE: SP-7XE PRODUCTION LIFT VER B		
SIZE: DWG. NO. A	5260681	REV C
SCALE: 1:30		
SHEET 2 OF 3		

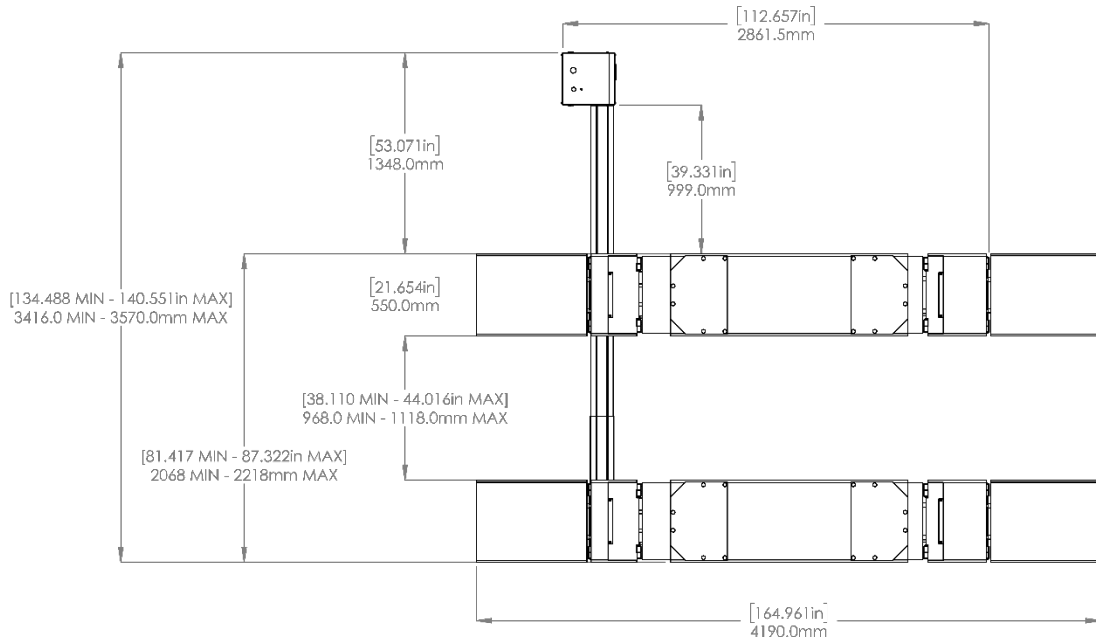

BP BendPak
 1645 LEMONWOOD DR.
 SANTA PAULA, CA 93060

TITLE: **SP-7XE PRODUCTION LIFT VER B**

SIZE DWG. NO. **A 5260681** REV **C**

SCALE: 1:30 SHEET 3 OF 3

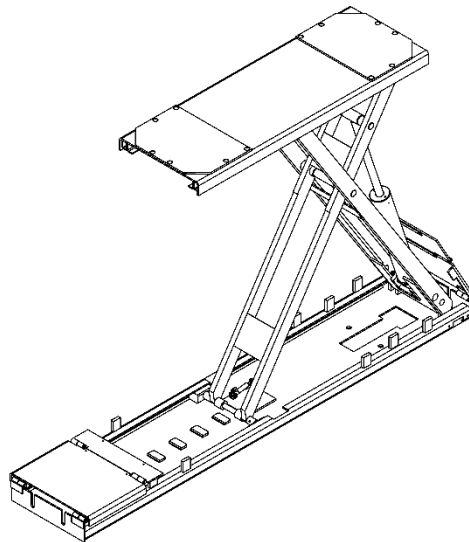

WHERE USED
 SP-7XE SERIES

ITEM NO	PART NUMBER	DESCRIPTION	QTY	REV
1	5601804	SP-7XE BASE WELDMENT	1	B
2	5620278	SP-7XE OUTER SCISSOR ARM WELDMENT	1	C
3	5746449	SP-7XE CYLINDER BOTTOM PIN	1	A
4	5215495	SP-7XE INNER ARM ASSEMBLY	1	C
5	5716150	SP-7XE SLIDE BLOCK, BOTTOM	2	C
6	5737243	SP-7XE SAFETY ROCKER ARM	1	A
7	5550087	FTG ELB .04 COMP x .02 NPT	1	---
8	5502195	AIR CYLINDER: Ø19mm x 25 STROKE	1	---
9	5503625	FEMALE ROD END M6 x 33	1	---
10	5545005	WASHER, M6 x 12mm FLAT	2	---
11	5535357	NUT M6 x 1.0, NL, CLB	15	---
12	5530093	HBB M6 x 1.0 x 20mm	1	---
13	5530757	HBB M6 x 1.0 x 40	1	---
14	5716155	SP-7XE SLIDE BLOCK, TOP	2	B
15	5505727	SP-7XE MAIN SCISSOR PIVOT PIN	1	A
16	5502091	CYLINDER ASSEMBLY Ø33.5 x 20.49	1	F
17	5746448	SP-7XE CYLINDER TOP PIN	1	A
18	5601653	SP-7XE RAMP WELDMENT	1	B
19	5746610	SP-7XE RAMP ANCHOR PIN	2	B
20	5216040	SP-7XE RAMP COVER ASSEMBLY, CYLINDER SIDE	1	A
21	5216041	SP-7XE RAMP COVER ASSEMBLY, SAFETY SIDE	1	A
22	5540006	SNAP RING TRUARC 5103-100	2	---
23	5505716	SP-7XE RAMP COVER HINGE PIN	4	B
24	5540116	TRUARC Ø12mm 5103-50	4	---
25	5545347	WASHER M12 x 24mm FLAT, CL 8.8	4	---
26	5550395	FTG TEE .04 COMP x .04 COMP x .04 COMP	1	---
27	5530392	SSS M6 x 1.25 x 30 EXTENDED NL	1	B
28	5755145	TUBE, Ø44 x Ø38 x 138mm	1	B
29	5746450	SP-7XE SCISSOR BOTTOM PIN	2	A
30	5715050	SP-7 RAMP BOLT ON RUBBER PAD	2	A
31	5530466	ELEVATOR BOLT M6 x 1.0 x 30	8	---
32	5530364	ELEVATOR BOLT M6 x 1.0 x 25	4	---

DO NOT SCALE DRAWING

DESIGNER: NAME: DATE: **03/30/2022**

CHECKED: TM: **BP BendPak**
 1645 LEMONWOOD DR.
 SANTA PAULA, CA 93060

THIRD ANGLE PROJECTION

UNITS: DIMENSIONS ARE IN: **MM**

PROPERTY AND CONFIDENTIALITY NOTICE: THIS DRAWING IS THE PROPERTY OF BENDPAK INC. AND IS NOT TO BE REPRODUCED OR TRANSMITTED IN ANY FORM OR BY ANY MEANS, ELECTRONIC OR MECHANICAL, INCLUDING PHOTOCOPYING, RECORDING, OR BY ANY INFORMATION STORAGE AND RETRIEVAL SYSTEM.

TITLE: **SP-7XE RAMP ASSEMBLY**

SIZE DWG. NO. **A 5216132** REV **C**

SCALE: 1:20 SHEET 3 OF 3

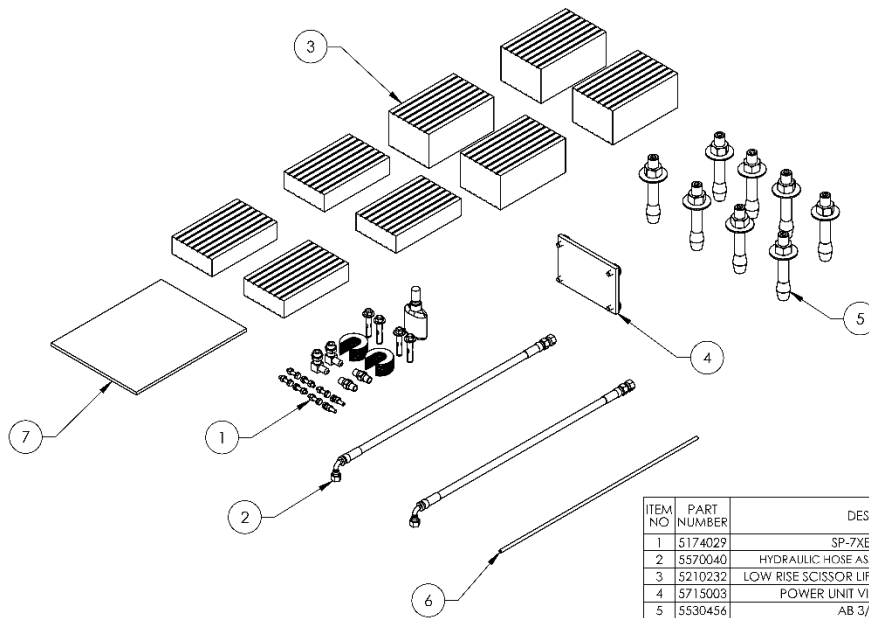
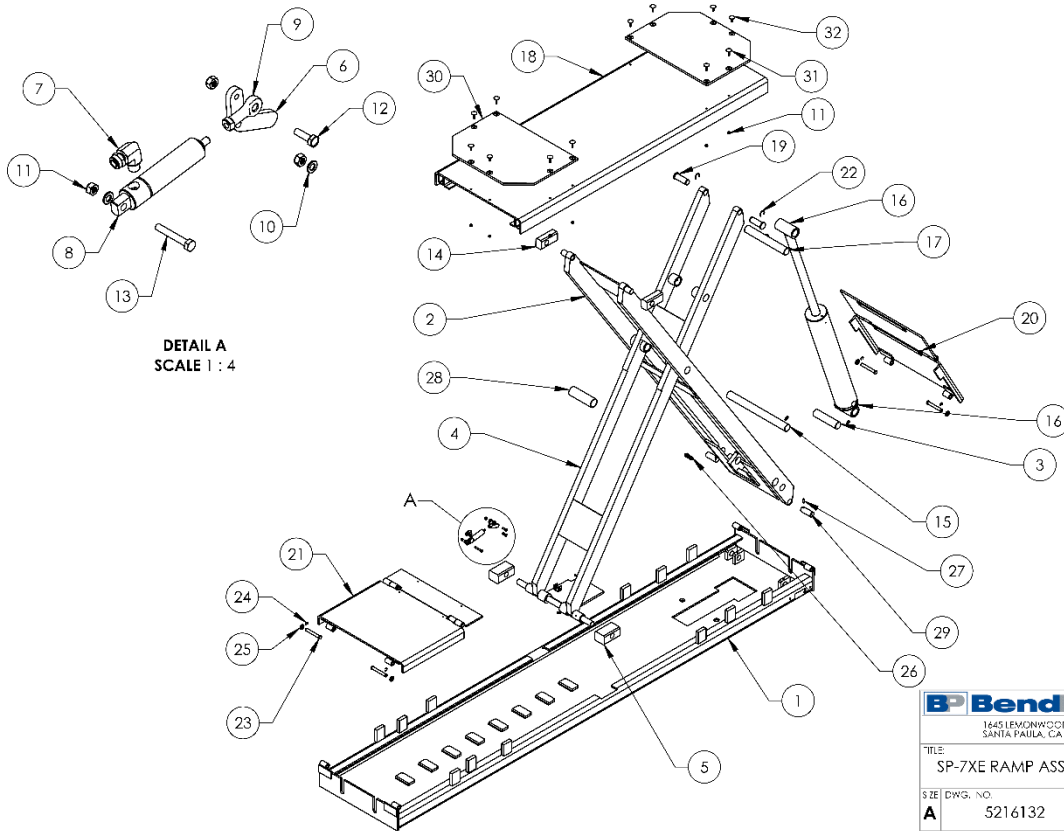

ITEM NO	PART NUMBER	DESCRIPTION	QTY	REV
1	5174029	SP-7XE PARTS BAG	1	F
2	5570040	HYDRAULIC HOSE ASSEMBLY Ø6.35 x 4270mm SB	2	D
3	5210232	LOW RISE SCISSOR LIFT RUBBER PAD KIT, SET OF 8	1	A
4	5715003	POWER UNIT VIBRATION DAMPENER	1	B
5	5530456	AB 3/4" x 4 - 3/4"	8	-
6	5570795	1/4" POLY-FLO TUBING	10820mm*	-
7	5900010	SP-7XE INSTALLATION MANUAL	1	-

WHERE USED
SP-7XE

NOTE: UNLESS OTHERWISE SPECIFIED...
1. SEE SHIPPING INSTRUCTIONS FOR FINAL PACKAGING
2. (*) LENGTH FOR REFERENCE ONLY

DO NOT SCALE DRAWING

DRAWN	IM	DATE	06/19/2017
CHECKED	OR	DATE	07/01/2021

THIRD ANGLE PROJECTION

BP BendPak
1645 LEMO WOOD DR
SANTA PAULA, CA 95660

TITLE: SP-7XE PARTS BOX

SIZE: A, DWG. NO.: 5250110, REV: G

SCALE: 1:8, SHEET 1 OF 1

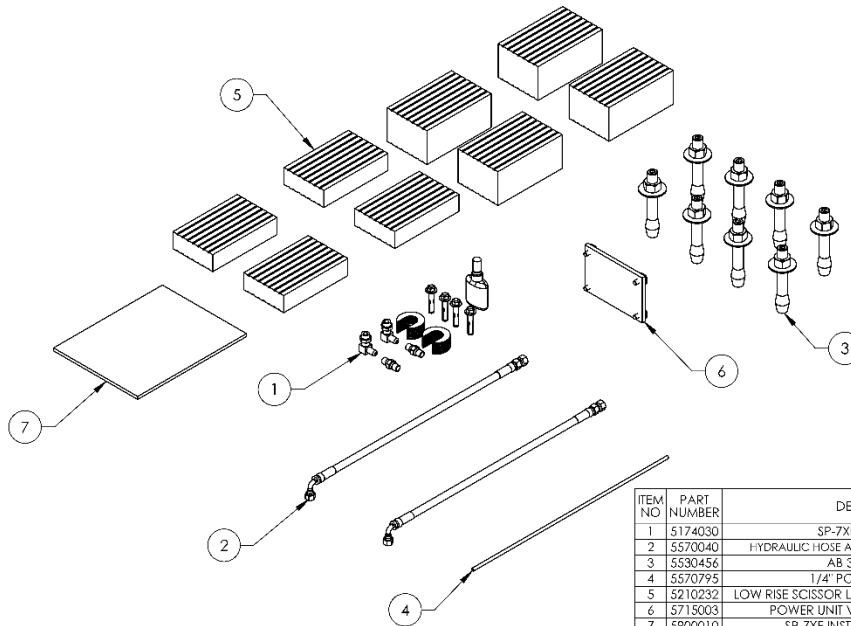

WHERE USED
SP-7XEF

ITEM NO	PART NUMBER	DESCRIPTION	QTY	REV
1	5174030	SP-7XEF PARTS BAG	1	F
2	5570040	HYDRAULIC HOSE ASSEMBLY Ø6.35 x 4270mm 5B	2	D
3	5530456	AB 3/4" x 4 - 3/4"	8	-
4	5570795	1/4" POLY-FLO TUBING	10820mm*	-
5	5210232	LOW RISE SCISSOR LIFT RUBBER PAD KIT, SET OF 8	1	A
6	5715003	POWER UNIT VIBRATION DAMPENER	1	B
7	5900010	SP-7XE INSTALLATION MANUAL	1	-

DO NOT SCALE DRAWING	NAME	DATE	 1645 LEMONWOOD DR. SANTA PAULA, CA 93060
	DRAWN	TM	
	CHECKED	CR	04/14/2020
THIRD ANGLE PROJECTION 	TITLE		SP-7XEF PARTS BOX
 PROPRIETARY AND CONFIDENTIAL INFORMATION. IT IS THE PROPERTY OF BENDPAK INC. AND IS NOT TO BE REPRODUCED OR TRANSMITTED IN ANY FORM OR BY ANY MEANS, ELECTRONIC OR MECHANICAL, INCLUDING PHOTOCOPYING, RECORDING, OR BY ANY INFORMATION STORAGE AND RETRIEVAL SYSTEM.	SIZE	DWG. NO.	REV
	A	5250174	G
SCALE: 1:8			SHEET 1 OF 1

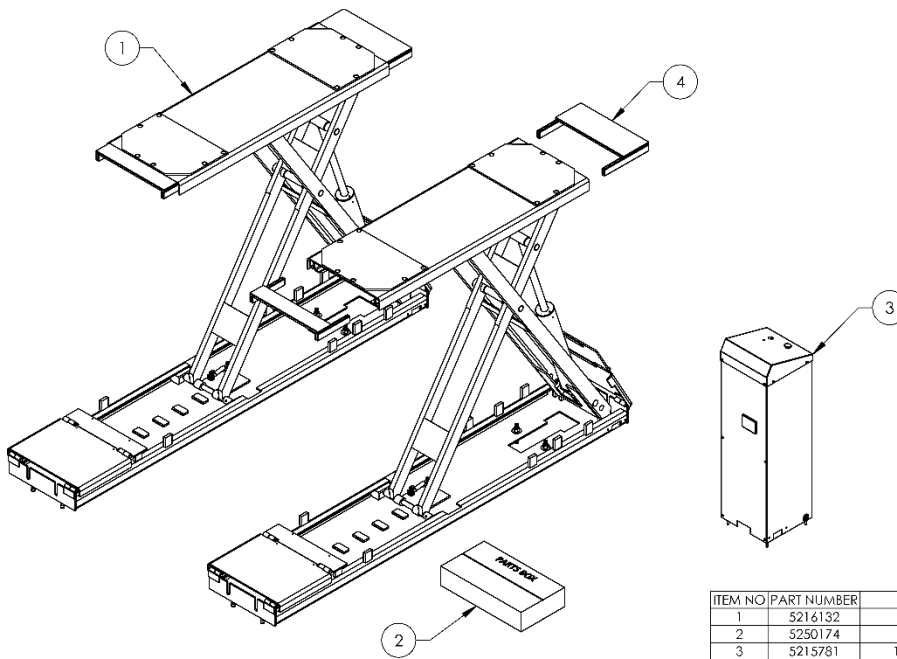

ITEM NO	PART NUMBER	DESCRIPTION	QTY	REV
1	5216132	SP-7XE RAMP ASSEMBLY	2	C
2	5250174	SP-7XEF PARTS BOX	1	G
3	5215781	TALL POWER UNIT CONSOLE ASSEMBLY	1	F
4	5210257	SP-7XE RAMP EXTENSION KIT	2	A

DO NOT SCALE DRAWING	NAME	DATE	 1645 LEMONWOOD DR. SANTA PAULA, CA 93060
	DRAWN	TM	
	CHECKED		
THIRD ANGLE PROJECTION 	TITLE		SP-7XEF PRODUCTION LIFT VER B
 PROPRIETARY AND CONFIDENTIAL INFORMATION. IT IS THE PROPERTY OF BENDPAK INC. AND IS NOT TO BE REPRODUCED OR TRANSMITTED IN ANY FORM OR BY ANY MEANS, ELECTRONIC OR MECHANICAL, INCLUDING PHOTOCOPYING, RECORDING, OR BY ANY INFORMATION STORAGE AND RETRIEVAL SYSTEM.	SIZE	DWG. NO.	REV
	A	5260682	C
SCALE: 1:25			SHEET 1 OF 3

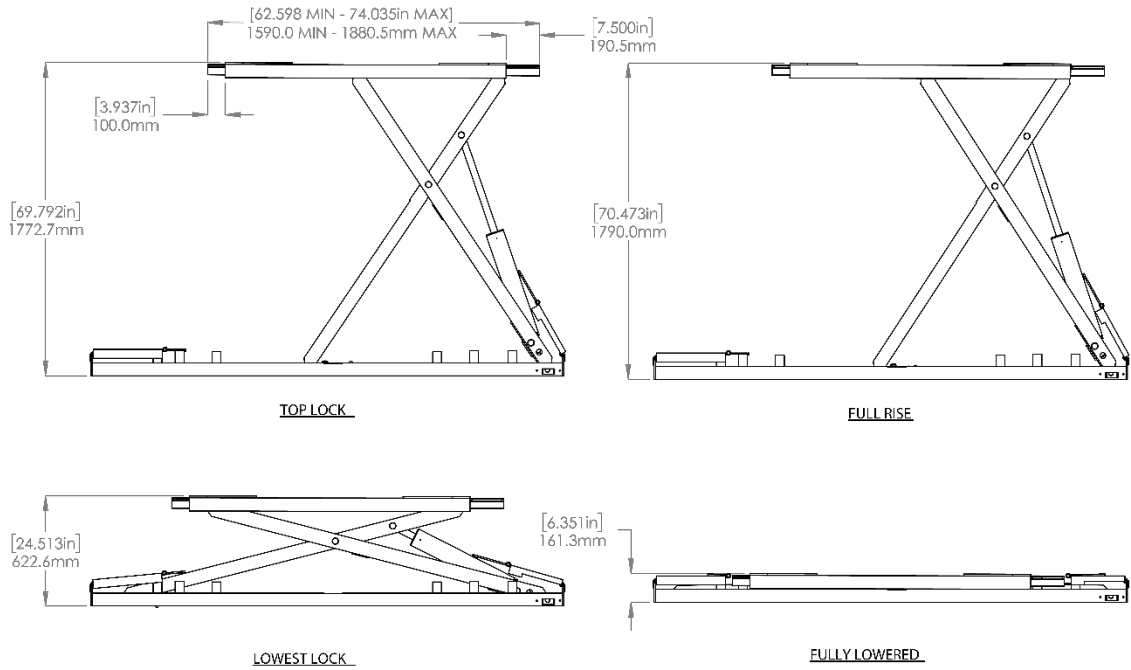

BP BendPak	
1645 EMOHWOOD DR. SANTA PALLA, CA 95060	
TITLE: SP-7XEF PRODUCTION LIFT VER B	
SIZE DWG. NO.	REV
A 5260682	C
SCALE: 1:25	SHEET 2 OF 3

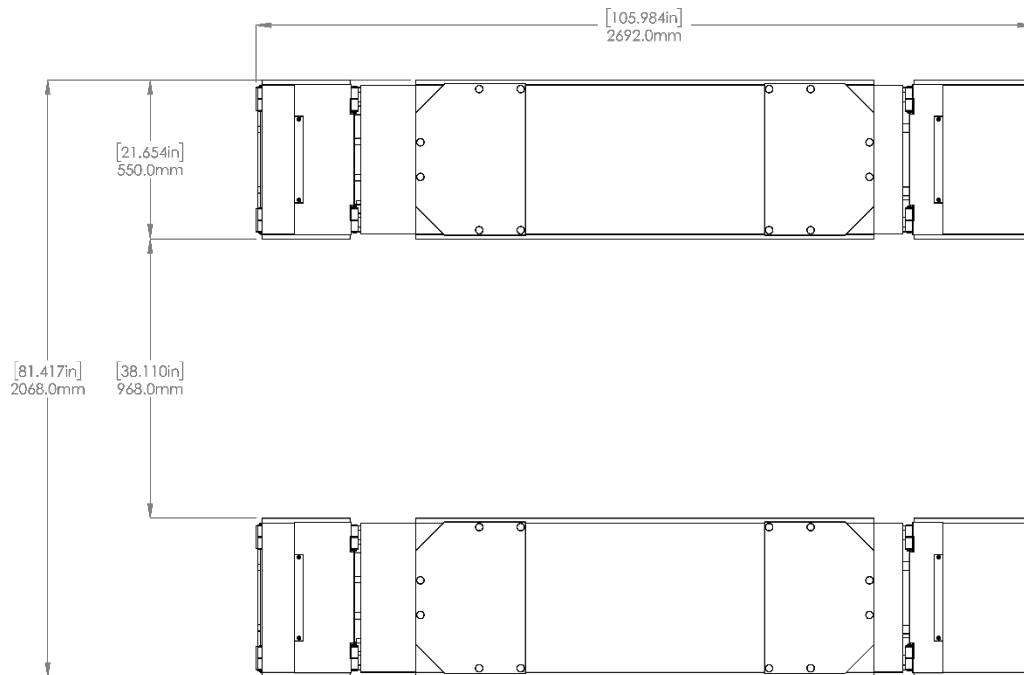

BP BendPak	
1645 EMOHWOOD DR. SANTA PALLA, CA 95060	
TITLE: SP-7XEF PRODUCTION LIFT VER B	
SIZE DWG. NO.	REV
A 5260682	C
SCALE: 1:15	SHEET 3 OF 3

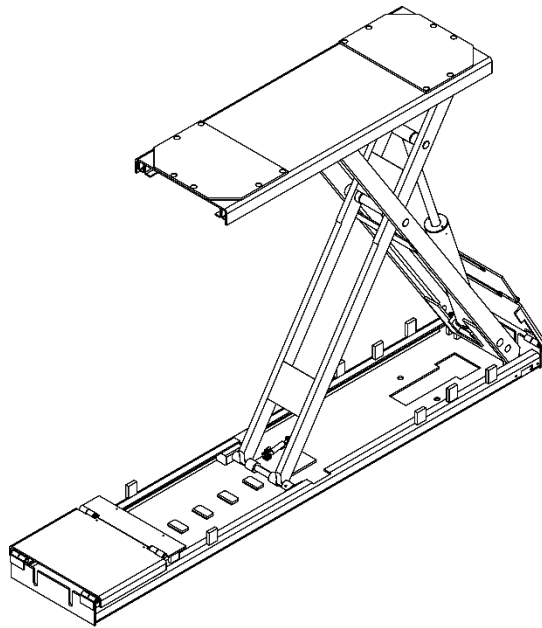

WHERE USED
SP-7XE SERIES

ITEM NO	PART NUMBER	DESCRIPTION	QTY	REV
1	5601804	SP-7XE BASE WELDMENT	1	B
2	5620278	SP-7XE OUTER SCISSOR ARM WELDMENT	1	C
3	5746449	SP-7XE CYLINDER BOTTOM PIN	1	A
4	5215485	SP-7XE INNER ARM ASSEMBLY	1	C
5	5716150	SP-7XE SLIDE BLOCK, BOTTOM	2	C
6	5737243	SP-7XE SAFETY ROCKER ARM	1	A
7	5550087	FTG ELB -04 COMP x -02 NPT	1	--
8	5502195	AIR CYLINDER, Ø19mm x 25 STROKE	1	--
9	5505625	FEMALE ROD END M6 x 33	1	--
10	5545005	WASHER, M6 x 12mm FLAT	2	--
11	5535357	NUT M6 x 1.0, NL CL8	15	--
12	5530093	HBB M6 x 1.0 x 20mm	1	--
13	5530757	HBB M6 x 1.0 x 40	1	--
14	5716155	SP-7XE SLIDE BLOCK, TOP	2	B
15	5505727	SP-7XE MAIN SCISSOR PIVOT PIN	1	A
16	5502021	CYLINDER ASSEMBLY Ø3.5 x 20.49	1	F
17	5746448	SP-7XE CYLINDER TOP PIN	1	A
18	5601653	SP-7XE RAMP WELDMENT	1	B
19	5746610	SP-7XE RAMP ANCHOR PIN	2	B
20	5216040	SP-7XE RAMP COVER ASSEMBLY, CYLINDER SIDE	1	A
21	5216041	SP-7XE RAMP COVER ASSEMBLY, SAFETY SIDE	1	A
22	5540006	SNAP RING TRUARC 5103-100	2	--
23	5505716	SP-7XE RAMP COVER HINGE PIN	4	B
24	5540116	TRUARC Ø12mm 5103-50	4	--
25	5545347	WASHER M12 x 24mm FLAT, CL 8,8	4	--
26	5550395	FTG TEE -04 COMP x -04 COMP x -04 COMP	1	--
27	5530372	SSS M8 x 1.25 x 20 EXTENDED NL	8	--
28	5755145	TUBE, Ø44 x Ø38 x 138mm	1	B
29	5746450	SP-7XE SCISSOR BOTTOM PIN	2	A
30	5715050	SP-7 RAMP BOLT-ON RUBBER PAD	2	A
31	5530466	ELEVATOR BOLT M6 x 1.0 x 30	8	--
32	5530364	ELEVATOR BOLT M6 x 1.0 x 25	4	--

NO. ON SCALE DRAWING	NAME	DATE	 1645 LEMONWOOD DR. SANTA PAULA, CA 93060
DRAWN	TM	03/30/2022	
CHECKED			TITLE
DIMENSIONS ARE IN INCH			SP-7XE RAMP ASSEMBLY
 THIRD ANGLE PROJECTION			SPEC. DWG. NO.
 PROPRIETARY AND CONFIDENTIAL THE INFORMATION CONTAINED HEREIN IS THE PROPERTY OF BENDPAK INC. AND IS TO BE USED FOR THE PURPOSES SPECIFIED WITHOUT THE WRITTEN PERMISSION OF BENDPAK INC.			REV
			A 5216132 C
			SCALE: 1:20 SHEET 1 OF 2

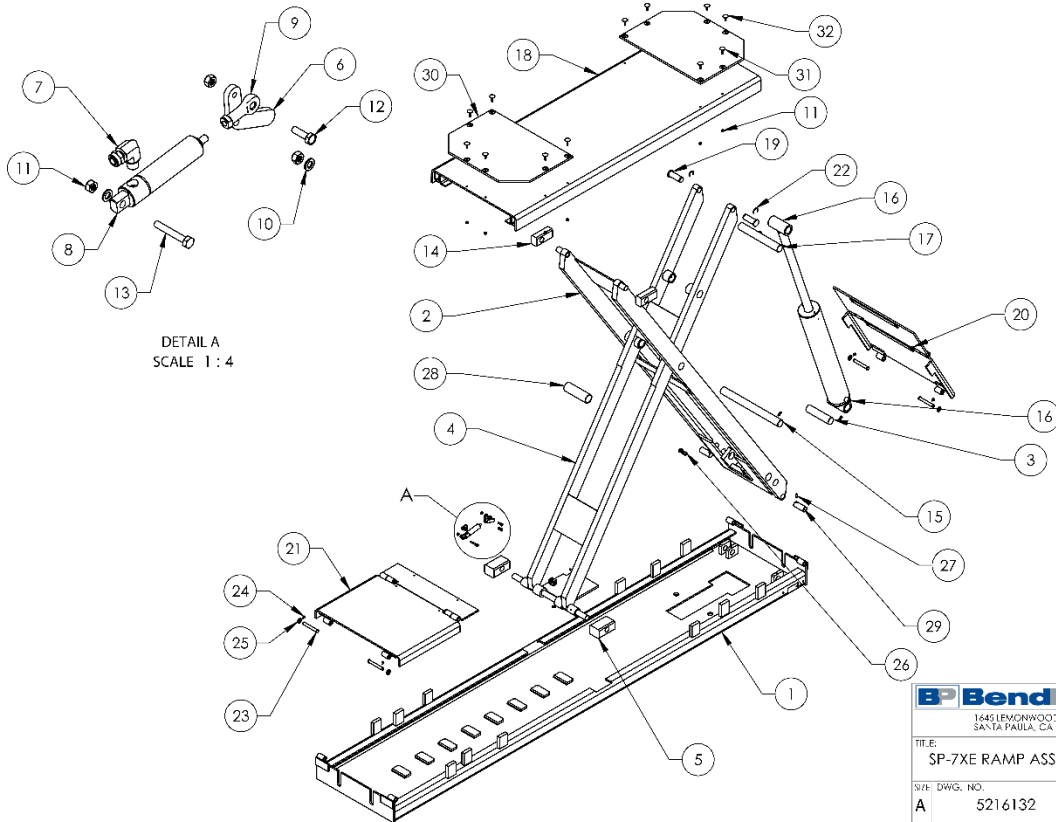

 1645 LEMONWOOD DR. SANTA PAULA, CA 93060	
TITLE:	
SP-7XE RAMP ASSEMBLY	
SPEC. DWG. NO.	REV
A 5216132	C
SCALE: 1:20 SHEET 2 OF 2	

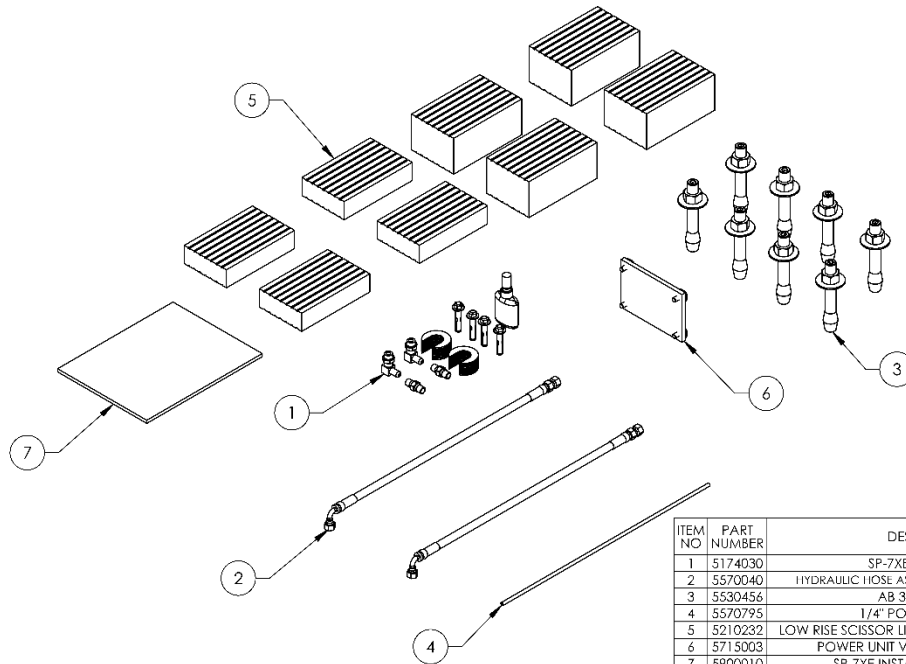

WHERE USED
SP-7XEF

ITEM NO	PART NUMBER	DESCRIPTION	QTY	REV
1	5174030	SP-7XEF PARTS BAG	1	F
2	5570040	1 HYDRAULIC HOSE ASSEMBLY Ø6.35 x 42/0mm SB	2	D
3	5530456	AB 3/4" x 4 - 3/4"	8	-
4	5570795	1/4" POLY-FLO TUBING	10820mm*	-
5	5210232	LOW RISE SCISSOR LIFT RUBBER PAD KIT, SET OF 8	1	A
6	5715003	POWER UNIT VIBRATION DAMPENER	1	B
7	5900010	SP-7XE INSTALLATION MANUAL	1	-

DO NOT SCALE DRAWING	NAME	DATE	 1645 LEMONWOOD DR. SANTA PAULA, CA 93866	
	DRAWN	TM		06/21/2017
	CHECKED	OR	04/14/2020	
DIMENSIONS ARE IN MM	THIRD ANGLE PROJECTION		TITLE: SP-7XEF PARTS BOX	
 <small>PROPRIETARY AND CONFIDENTIAL THIS INFORMATION IS THE PROPERTY OF BENDPAK INC. IT IS TO BE KEPT IN CONFIDENCE AND IS NOT TO BE REPRODUCED OR TRANSMITTED IN ANY FORM OR BY ANY MEANS, WITHOUT THE WRITTEN PERMISSION OF BENDPAK INC.</small>	SIZE	DWG. NO.	REV	
	A	5250174	G	
			SCALE: 1:8	SHEET 1 OF 1

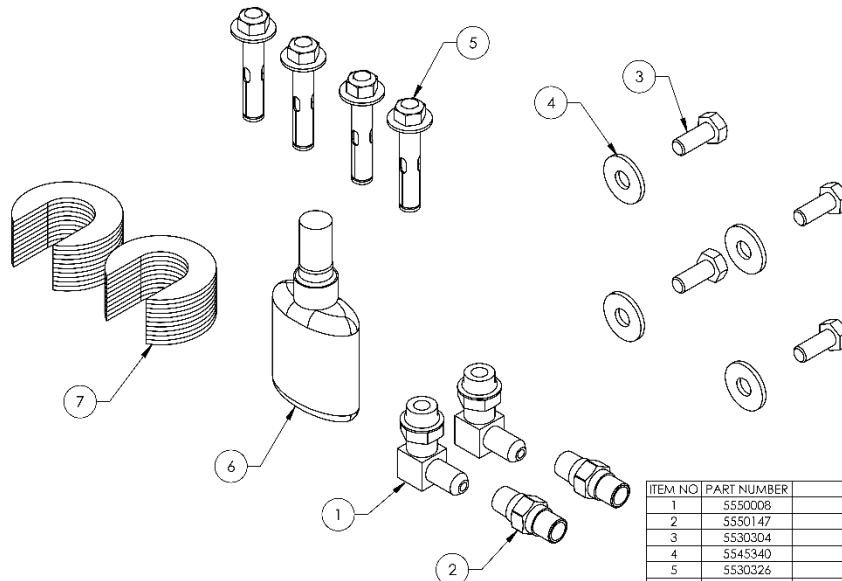

WHERE USED
SP-7XEF

ITEM NO	PART NUMBER	DESCRIPTION	QTY	REV
1	5550008	FTG ELB -04 JIC -06L ORB	2	-
2	5550147	FTG NPL -04 JIC x -04 NPT	2	-
3	5530304	HHB M8 x 1.25 x 20	4	-
4	5545340	WASHER M8 x 24 FLAT	4	-
5	5530326	AB Ø3/8" x 2-1/4"	4	-
6	5580012	LIQUID PTFE THREAD SEALANT 50ml	1	-
7	5545535	C WASHER SHIM FOR LIFTS	20	-

DO NOT SCALE DRAWING	NAME	DATE	 1645 LEMONWOOD DR. SANTA PAULA, CA 93866	
	DRAWN	TM		06/21/2017
	CHECKED	OR	04/14/2020	
DIMENSIONS ARE IN MM	THIRD ANGLE PROJECTION		TITLE: SP-7XEF PARTS BAG	
 <small>PROPRIETARY AND CONFIDENTIAL THIS INFORMATION IS THE PROPERTY OF BENDPAK INC. IT IS TO BE KEPT IN CONFIDENCE AND IS NOT TO BE REPRODUCED OR TRANSMITTED IN ANY FORM OR BY ANY MEANS, WITHOUT THE WRITTEN PERMISSION OF BENDPAK INC.</small>	SIZE	DWG. NO.	REV	
	A	5174030	F	
			SCALE: 1:2	SHEET 1 OF 1

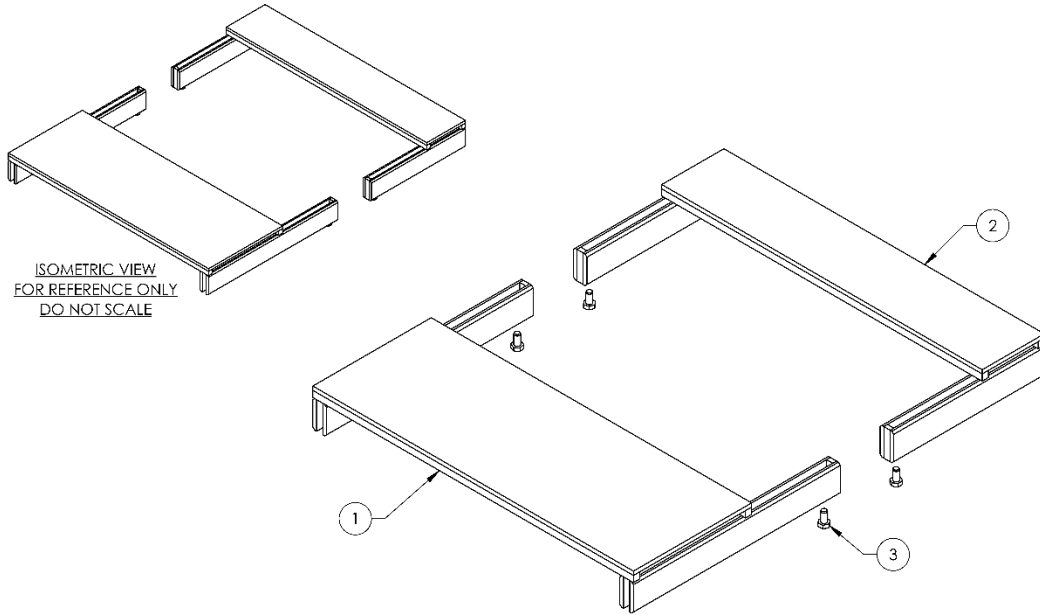

ISOMETRIC VIEW
FOR REFERENCE ONLY
DO NOT SCALE

WHERE USED
SP-7XE SERIES

ITEM NO	PART NUMBER	DESCRIPTION	QTY	REV
1	5601615	SP-7XE RAMP LONG EXTENSION	1	A
2	5601614	SP-7XE RAMP SHORT EXTENSION	1	A
3	5530303	HHB M8 x 1.25 x 1.6	4	--

DO NOT SCALE DRAWING	NAME	DATE	 1645 LENOX WOOD DR. SANTA PAULA, CA 93269
DRAWN	TJM	11/13/2020	
CHECKED	CR	07/15/2021	TITLE
THIRD ANGLE PROJECTION			SP-7XE RAMP EXTENSION KIT
			SIZE DWG. NO.
			A 5210257
<small>PROPRIETARY AND CONFIDENTIAL ALL INFORMATION CONTAINED HEREIN IS THE PROPERTY OF BENDPAK INC. AND IS TO BE KEPT IN STRICTLY CONFIDENTIAL. NO PART OF THIS DOCUMENT IS TO BE REPRODUCED OR TRANSMITTED IN ANY FORM OR BY ANY MEANS, ELECTRONIC OR MECHANICAL, INCLUDING PHOTOCOPYING, RECORDING, OR BY ANY INFORMATION STORAGE AND RETRIEVAL SYSTEM.</small>			REV
			A
			SCALE: 1:5
			SHEET 1 OF 1

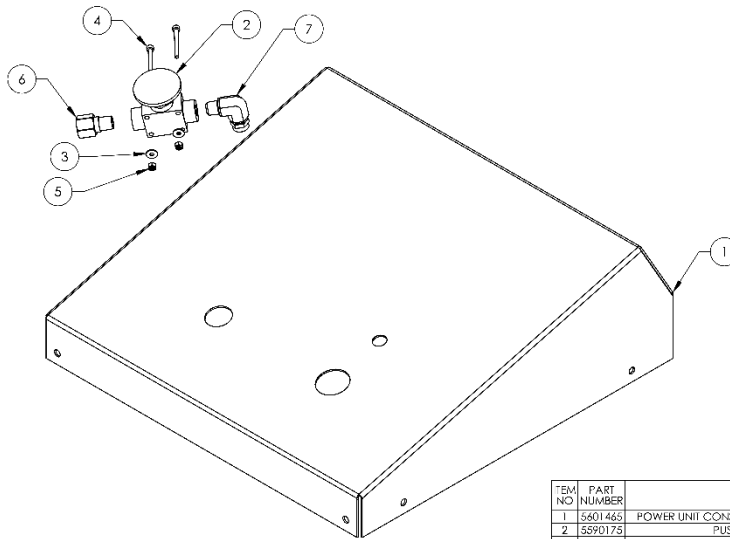

WHERE USED
XR-12AE
SP-7XE SERIES
PRODDLT SERIES
MDS-6 SERIES

ITEM NO	PART NUMBER	DESCRIPTION	QTY	REV
1	5601465	POWER UNIT CONSOLE COVER WELDMENT (3 BUTTON)	1	A
2	5590175	PUSH BUTTON AIR VALVE	1	--
3	5545024	WASHER, M3 x 9mm FLAT	2	--
4	5530043	SHIMS, M3 x 0.5 x 30	2	--
5	5535020	NUT, M3 x D.S., NL, CLR	2	--
6	5550486	FIG NPL-02 NPT x -04 NPT	1	--
7	5550087	FIG ELB-04 COMP X-02 NPT	1	--

DO NOT SCALE DRAWING	NAME	DATE	 1645 LENOX WOOD DR. SANTA PAULA, CA 93269
DRAWN	TJM	06/21/2019	
CHECKED	CR	06/07/2020	TITLE
THIRD ANGLE PROJECTION			3-BUTTON 110/220V CONSOLE TOP
			SIZE DWG. NO.
			A 5215857
<small>PROPRIETARY AND CONFIDENTIAL ALL INFORMATION CONTAINED HEREIN IS THE PROPERTY OF BENDPAK INC. AND IS TO BE KEPT IN STRICTLY CONFIDENTIAL. NO PART OF THIS DOCUMENT IS TO BE REPRODUCED OR TRANSMITTED IN ANY FORM OR BY ANY MEANS, ELECTRONIC OR MECHANICAL, INCLUDING PHOTOCOPYING, RECORDING, OR BY ANY INFORMATION STORAGE AND RETRIEVAL SYSTEM.</small>			REV
			C
			SCALE: 1:3
			SHEET 1 OF 1

REVISION				
REV	DESCRIPTION	DATE	EDITED BY	E/C#
D	ADDED 5906015, 5905477 AND 5905478, REPLACED 5701259 WITH 5215857	03/26/2020	TM	01152
E	ADDED 5905138	12/30/2020	CA	01236
F	REPLACED 5905138, 5905477, 5905478, AND 5906015 WITH COLORS & GRAPHICS NOTE, UPDATED BOM REVISION	09/30/2021	CA	01350

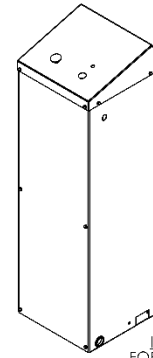
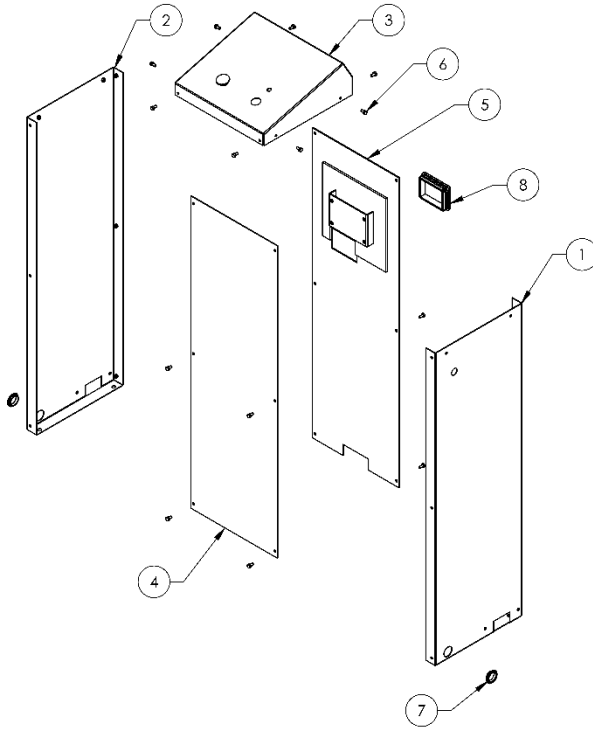

ISOMETRIC VIEW
FOR REFERENCE ONLY
DO NOT SCALE

ITEM NO.	PART NUMBER	DESCRIPTION	QTY	REV
1	5601202	TALL POWER UNIT CONSOLE WELDMENT, R.H.	1	B
2	5601165	TALL POWER UNIT CONSOLE WELDMENT, L.H.	1	C
3	5215857	3-BUTTON 110/220V CONSOLE TOP	1	C
4	5737012	TALL POWER UNIT CONSOLE DOOR	1	C
5	5601166	TALL POWER UNIT CONSOLE DOOR WELDMENT, REAR	1	D
6	5530031	HHB M6 x 1.0 x 12mm	15	---
7	5520329	GROMMET GRO-1 25-UL CAPPLUGS	2	---
8	5715196	D2/XPR POLYETHYLENE COVER BLOCK 105 x 80	1	D

DO NOT SCALE DRAWING	NAME	DATE	BendPak 1645 LEMMONWOOD DR. SANTA PAULA, CA 93060
	DRAWN TM	05/01/2018	
DI METER ONE ARE IN MM	CHECKED CR	10/01/2021	TITLE: TALL POWER UNIT CONSOLE ASSEMBLY
☺	THIRD ANGLE PROJECTION		SHEET DWG. NO. A 5215781
	<small>PROPRIETARY AND CONFIDENTIAL THIS DRAWING IS THE PROPERTY OF BENDPAK INC. IT IS TO BE USED ONLY FOR THE PROJECT AND QUANTITY SPECIFIED HEREON. NO PARTS OR INFORMATION FROM THIS DRAWING IS TO BE REPRODUCED OR TRANSMITTED IN ANY FORM OR BY ANY MEANS, ELECTRONIC OR MECHANICAL, INCLUDING PHOTOCOPYING, RECORDING, OR BY ANY INFORMATION STORAGE AND RETRIEVAL SYSTEM, WITHOUT THE WRITTEN PERMISSION OF BENDPAK INC.</small>		REV F
SCALE: 1:12			SHEET 1 OF 1

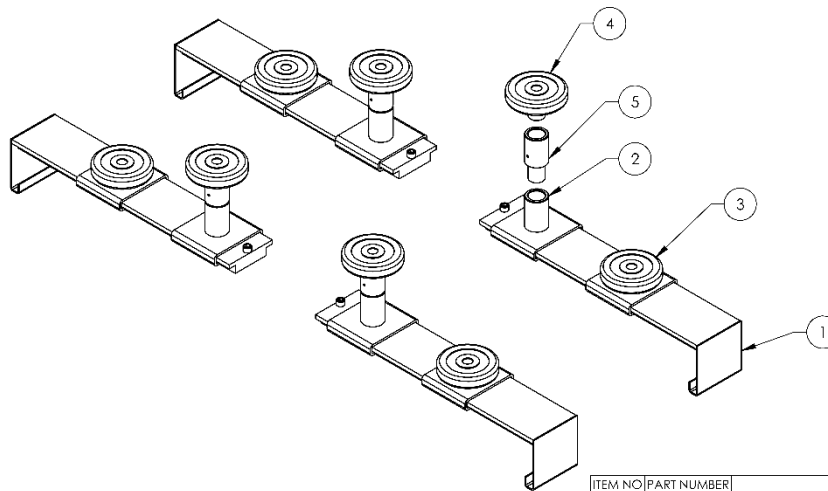





WHERE USED
SP-7XE SERIES

NEXT ASSEMBLY
ACCESSORY

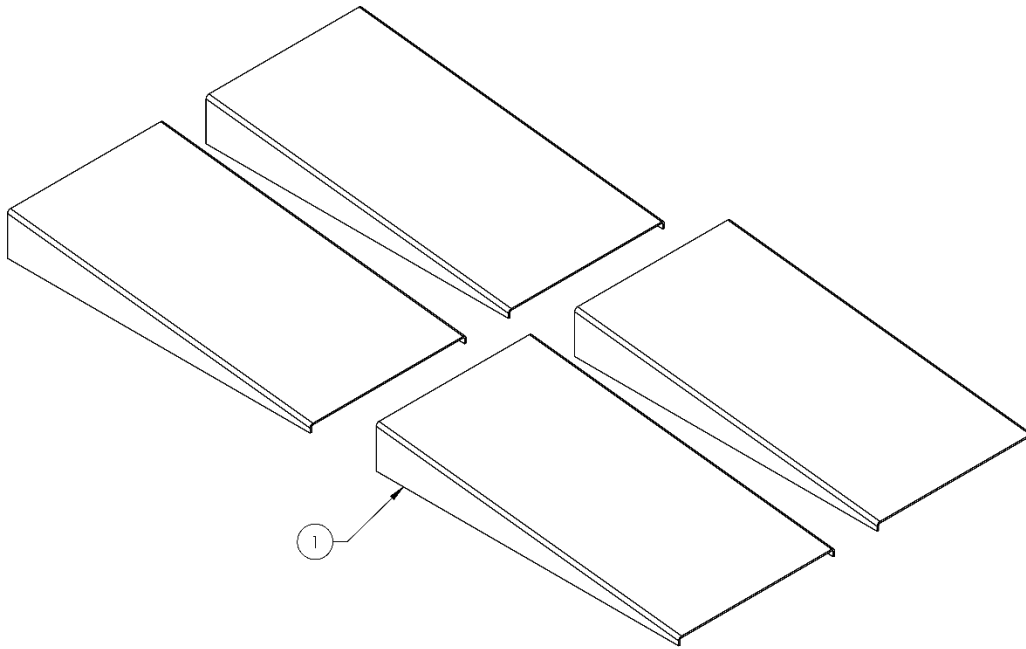
ITEM NO.	PART NUMBER	DESCRIPTION	QTY	REV
1	5215837	SP-7XE EXTENSION ARM ASSEMBLY	4	A
2	5400257	TALL LIFT PAD WELDMENT	4	E
3	5215523	SLIDING SHORT ROUND LIFT PAD ASSEMBLY	4	G
4	5215507	ROUND LIFT PAD ADAPTER ASSEMBLY	4	G
5	5746390	MEDIUM LIFT PAD EXTENSION Ø35 x 113mm	4	E

DO NOT SCALE DRAWING	NAME	DATE	BendPak 1645 LEMMONWOOD DR. SANTA PAULA, CA 93060
	DRAWN TM	04/05/2019	
DI METER ONE ARE IN MM	CHECKED CR	10/01/2021	TITLE: SP-7XE ARM KIT
☺	THIRD ANGLE PROJECTION		SHEET DWG. NO. A 5210214
	<small>PROPRIETARY AND CONFIDENTIAL THIS DRAWING IS THE PROPERTY OF BENDPAK INC. IT IS TO BE USED ONLY FOR THE PROJECT AND QUANTITY SPECIFIED HEREON. NO PARTS OR INFORMATION FROM THIS DRAWING IS TO BE REPRODUCED OR TRANSMITTED IN ANY FORM OR BY ANY MEANS, ELECTRONIC OR MECHANICAL, INCLUDING PHOTOCOPYING, RECORDING, OR BY ANY INFORMATION STORAGE AND RETRIEVAL SYSTEM, WITHOUT THE WRITTEN PERMISSION OF BENDPAK INC.</small>		REV C
SCALE: 1:10			SHEET 1 OF 1



ITEM NO	PART NUMBER	DESCRIPTION		QTY	REV
1	5601766	SP-7XE EXTENDED DRIVE UP RAMP WELDMENT		4	A
DO NOT SCALE DRAWING		NAME	DATE	 1645 IRONWOOD DR. SANTA PAULA, CA 92386	
		DRAWN	CA 01/10/2022		
		CHECKED		TITLE: SP-7XE EXTENDED DRIVE UP RAMP KIT, SET OF 4	
DIMENSIONS ARE IN MM		THIRD ANGLE PROJECTION		SIZE	DWG. NO.
				A	5210306
				PROPRIETARY AND CONFIDENTIAL THIS INFORMATION IS CONTAINED HEREIN AND IS THE PROPERTY OF BENDPAK, INC. ANY REPRODUCTION, IN WHOLE OR IN PART, WITHOUT THE WRITTEN PERMISSION OF BENDPAK, INC. IS PROHIBITED.	
WHERE USED SP-7XE ACCESSORY		SCALE: 1:12		REV A	
				SHEET 1 OF 1	

Automotive Lift Institute (ALI) Store

You probably checked the [ALI's Directory of Certified Lifts](http://www.autolift.org/ali-directory-of-certified-lifts/) (www.autolift.org/ali-directory-of-certified-lifts/) before making your most recent Lift purchase, but did you know the **ALI Store** (www.autolift.org/ali-store/) offers a wide variety of professional, easy-to-use, and reasonably priced training and safety materials that will make your garage a safer place to work?

The ALI Store is your trusted source for workplace safety!



Lifting It Right Online Certificate Course. Make *sure* you and your people are lifting vehicles the right way.



ALI Lift Inspector Certification Program Registration. Become a **ALI Certified Lift Inspector**.

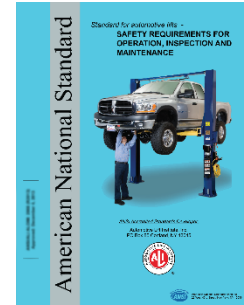

ANSI/ALI ALOIM Standard for Automotive Lifts. Safety Requirements for Operation, Inspection, and Maintenance.

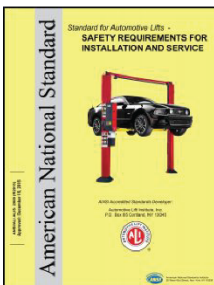

ANSI/ALI ALIS Standard. Safety Requirements for Installation and Service.



Guide to Identifying Vehicle Lifting Points for Frame-Engaging Lifts. Don't eyeball your lifting points, *know* where they are.



Lift Operator Safety Materials. Five safety documents in a single package.

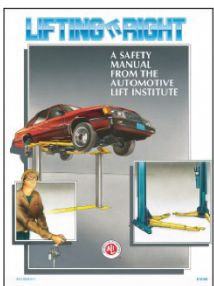

Lifting It Right. A hardcopy version of the *Lifting It Right* safety manual from the Automotive Lift Institute.

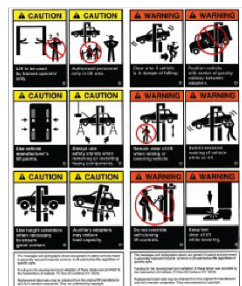

Uniform Warning Labels and Placards for 2-Posts. Labels in Mandarin, French Canadian, and Spanish are also available.



Safety Tips Card. Reminds your people of 13 key safety tips to follow daily.

Visit today and get the training and materials you need to work safely:
www.autolift.org/ali-store/.

Maintenance Log

Maintenance Log
