

Heavy Duty Workbench

Assembly and Operation Manual

Manual P/N 5900961 — Manual Revision B — October 2024

Models:

- RWB-2D – Two Drawer
- RWB-2S – Two Shelf
- RWB-1TD – One
Drawer, One Fluid Catch



READ FIRST



Do **not** operate this machine until you read and understand all the dangers, warnings, and cautions in this manual.

Designed and engineered by BendPak Inc. in Southern California, USA. Made in China.

 **DANGER**

Read the entire contents of this manual before using this product. Failure to follow the instructions and safety precautions in this manual can result in serious injury or death. Make sure all other operators also read this manual. Keep the manual near the product for future reference. By proceeding with setup and operation, you agree that you fully understand the contents of this manual.

Manual. RWB-2D, RWB-2S, RWB-1TD *Heavy Duty Workbench Assembly and Operation Manual*, P/N 5900327, Manual Revision B, Released September 2024.

Copyright. Copyright © 2024 by BendPak Inc. All rights reserved. You may make copies of this document if you agree that: you will give full attribution to BendPak Inc., you will not make changes to the content, you do not gain any rights to this content, and you will not use the copies for commercial purposes.

Trademarks. BendPak, the BendPak logo, Ranger, and the Ranger logo are registered trademarks of BendPak Inc. All other company, product, and service names are used for identification only. All trademarks and registered trademarks mentioned in this manual are the property of their respective owners.

Limitations. Every effort has been made to have complete and accurate instructions in this manual. However, product updates, revisions, and/or changes may have occurred since this manual was published. BendPak Ranger reserves the right to change any information in this manual without incurring any obligation for equipment previously or subsequently sold. BendPak Ranger is not responsible for typographical errors in this manual. Feel free to contact us at any time to get the latest information about any product: rangerproducts.com.

Warranty. The BendPak Ranger warranty is more than a commitment to you: it is also a commitment to the value of your new product. For full warranty details, contact your nearest BendPak Ranger dealer or visit bendpak.com/support/warranty. Go to bendpak.com/support/register-your-product/ and fill out the online form to register your product (be sure to click **Submit**).

Safety. Your new product was designed and manufactured with safety in mind. Your safety also depends on proper training and thoughtful operation. Do not set up, operate, maintain, or repair the unit without reading and understanding this manual and the labels on it; **do not use this product unless you can do so safely!**

Owner Responsibility. In order to maintain your product properly and to ensure operator safety, it is the responsibility of the product owner **to read and follow these instructions:**

- Follow all setup, operation, and maintenance instructions.
- Make sure product setup conforms to all applicable local, state, and federal codes, rules, and regulations, such as state and federal OSHA regulations and electrical codes.
- Read and follow all safety instructions. Keep them readily available for operators.
- Make sure all operators are properly trained, know how to safely operate the unit, and are properly supervised.
- Do not operate the product until you are certain that all parts are in place and operating correctly.
- Carefully inspect the product on a regular basis and perform all maintenance as required.
- Service and maintain the unit only with approved replacement parts.
- Keep the manual with the product and make sure all labels are clean and visible.

Only use this product if it can be used safely!

Unit Information. Enter the Model Number, Serial Number, and the Date of Manufacture from the label on your unit. This information is required for part or warranty issues.

Model: _____



Serial: _____

Date of Manufacture: _____



**SCAN FOR
DIGITAL PDF**

Model No.	<input type="text"/>
Revision	<input type="text"/>
Serial No.	<input type="text"/>
Date of Mfg.	<input type="text"/>
Voltage	<input type="text"/>

DANGER!
Disconnect Power
Before Servicing

Ranger Products
Santa Paula, CA, 93060 USA
www.rangerproducts.com

ENGINEERED BY RANGER PRODUCTS USA
MADE IN CHINA

Introduction

This manual describes the RWB-2D, RWB-2S, and RWB-1TD Heavy Duty Workbenches. More information about the full line of Ranger Products is available at rangerproducts.com.

This manual is mandatory reading for all users of these Heavy duty Workbenches, including anyone who assembles, operates, maintains, or repairs them.

 **DANGER** Be very careful when setting up, using, maintaining, or repairing this heavy duty work bench; failure to do so could result in property damage, product damage, injury, or (in very rare cases) death. Do not make modifications to the unit; this voids the warranty and increases the chances of injury or property damage. Make sure to read and follow the instructions on the labels on the unit.

Keep this manual on or near the Heavy Duty Workbench so that anyone who uses or services it can read it.

Technical support for your Heavy Duty Workbench is available from your distributor or directly from BendPak Ranger: using a web browser, visit the [BendPak Support website](#).

Shipping Information

Your Heavy Duty Workbench was carefully checked before shipping. Nevertheless, you should thoroughly inspect the shipment **before** you sign to acknowledge that you received it.

When you sign the bill of lading, it tells the carrier that the items on the invoice were received in good condition. **Do not sign the bill of lading until after you have inspected the shipment.** If any of the items listed on the bill of lading are missing or damaged, do not accept the shipment until the carrier makes a notation on the bill of lading that lists the missing or damaged goods.

If you discover missing or damaged goods **after** you receive the shipment and have signed the bill of lading, notify the carrier at once and request the carrier to make an inspection. If the carrier will not make an inspection, prepare a signed statement to the effect that you have notified the carrier (on a specific date) and that the carrier has failed to comply with your request.

It is difficult to collect for loss or damage after you have given the carrier a signed bill of lading. If this happens to you, file a claim with the carrier promptly. Support your claim with copies of the bill of lading, freight bill, invoice, and photographs, if available. Our willingness to assist in helping you process your claim does not make us responsible for collection of claims or replacement of lost or damaged materials.

Safety Considerations

Read this entire manual carefully before using your new product. Do not install or operate the product until you are familiar with all operating instructions and warnings. Do not allow anyone else to operate the product until they are familiar with all operating instructions and warnings.

 **WARNING** **California Proposition 65.** This product can expose you to chemicals including styrene and vinyl chloride which are on the list of over 900 chemicals identified by the State of California to cause cancer, birth defects or reproductive harm. Always use this product in accordance with BendPak's instructions. For more information, visit www.p65warnings.ca.gov.

 **WARNING** **Always** refer to the Material Safety Data Sheet (MSDS) for safe handling and disposal information on the fluids you intend to collect in the fluid reservoir of the RWB-1TD. MSDS are available from the fluid's supplier or manufacturer.

Safety Information

Please note the following:

- The product is a Heavy Duty Workbench. **Use it only for its intended purpose.**
- This safety information and the warnings throughout this manual cannot cover all possible conditions and situations that may occur. It must be understood by the operator that common sense and caution are required at all times when using this Heavy Duty Workbench.
- Read and understand all warnings, safety precautions and instructions prior to use.
- **Do not drain caustic or volatile fluids or fuels into the RWB-1TD!** These Fluids could cause damage to the equipment and personal injury.
- Do **not** weld to the Heavy Duty Workbench.
- Automotive Fluids may be hot and cause severe burns or injury to skin and eyes! Temperatures can exceed 220° F (104° C).
- Some oil systems may be under pressure; opening these systems while hot can cause oil to be sprayed forcefully and injury may result.
- Compressed air can be dangerous. **Never** point compressed air nozzles or fittings at yourself or anyone near you.
- Used oils are flammable, keep away from open flames or other ignition sources.
- Always comply with local, state and national regulations for the disposal of Waste Fluids.
- Repair leaks and clean fluid spills immediately.
- **Never** alter or make any modifications to the product.
- Assemble and use the Heavy Duty Workbench on a dry, clean, flat concrete surface.
- Make sure all operators read and understand the *Installation and Operation Manual*. Keep the manual near the Heavy Duty Workbench at all times.
- Make a visual inspection of the product before using it each time. Do not use the product if you find any missing or damaged parts. Instead, take the unit out of service, then contact an authorized repair facility, your distributor, or Ranger Products at **(805) 933-9970** follow the prompts to reach sales or service.
- Ranger recommends making a **thorough** inspection of the product at least once a year. Replace any damaged, cracked or severely worn parts, decals, or warning labels.
- Contact Ranger for parts replacement information (please have the model and serial number of your unit available) at **(805) 933-9970** follow the prompts to reach sales or service.

Important Safety Information

When using this equipment, basic safety precautions should always be followed, including:

- Read all instructions. Use only as described in this manual.
- Make sure all operators read and understand this *Installation and Operation Manual*. **Keep the manual near the Heavy Duty Workbench at all times.** The Heavy Duty Workbench should only be operated by authorized personnel. Keep children and untrained personnel away.

Symbols

Following are the symbols used in this manual:



DANGER

Calls attention to a hazard that **will** result in death or injury.



WARNING

Calls attention to a hazard or unsafe practice that **could** result in death or injury.



CAUTION

Calls attention to a hazard or unsafe practice that could result in personal injury, product damage, or property damage.

NOTICE

Calls attention to information that can help you use your equipment better.

Liability Information

BendPak Ranger assumes **no** liability for damages resulting from:

- Use of the equipment for purposes other than those described in this manual.
- Modifications to the equipment without prior, written permission from BendPak Ranger.
- Damage to the equipment from external influences.
- Incorrect operation of the equipment.

Specifications

Model RWB-2D

Height: 34-1/2 in. (876 mm) Depth: 25-1/4 in. (641 mm) Width: 59 in. (499 mm) No. Drawers: 2

Model RWB-2S

Height: 34-1/2 in. (876 mm) Depth: 25-1/4 in. (641 mm) Width: 79 in. (2009 mm) No. Shelves: 2





Model RWB-1TD

Height: 40 in. (1016 mm) Depth: 32 in. (813 mm) Width: 48 in. (1219 mm) Drawers/Shelves: 1/1

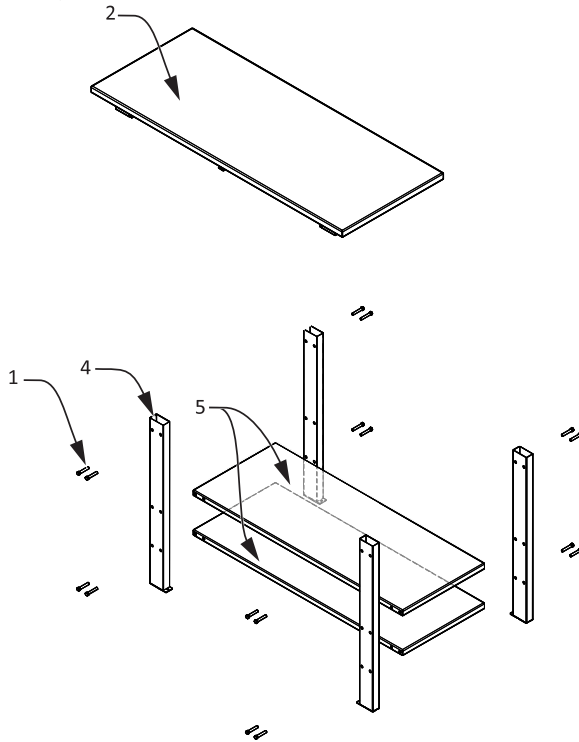
Components

The following illustrations detail the included parts of the Heavy Duty Workbench in each configuration.



Callout	Illustration	Count	Description
1	 M10 x 55	16 Pcs	Bolt with washer and nut
2		1 Pc	Workbench Top
//			
4		4 Pc	Legs
5		2 Pc	Shelf
//			
//			

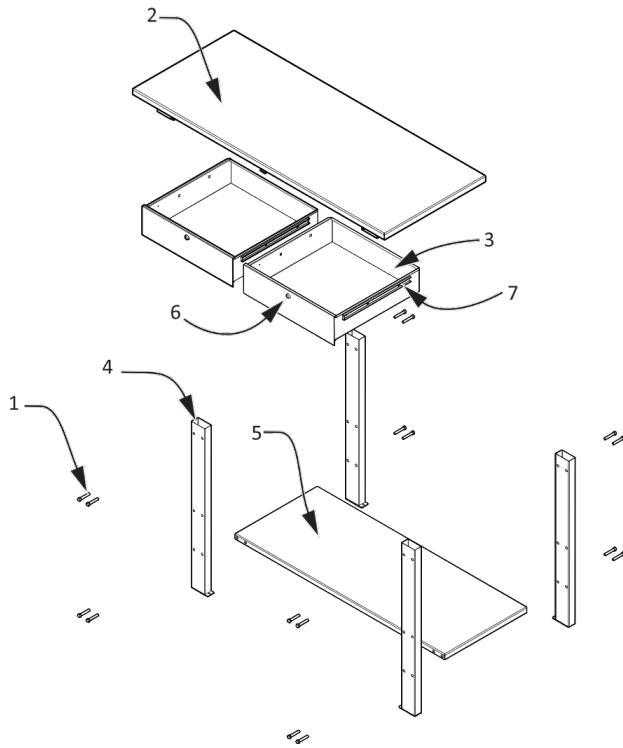

Callout	Illustration	Count	Description
1	M10 x 55	16 Pcs	Bolt with washer and nut
2		1 Pc	Workbench Top
3		2 Pc	Drawer
4		4 Pc	Legs
5		1 Pc	Shelf
6		1 Pc	Lock(s) for Drawer(s)
7		4 Pc	

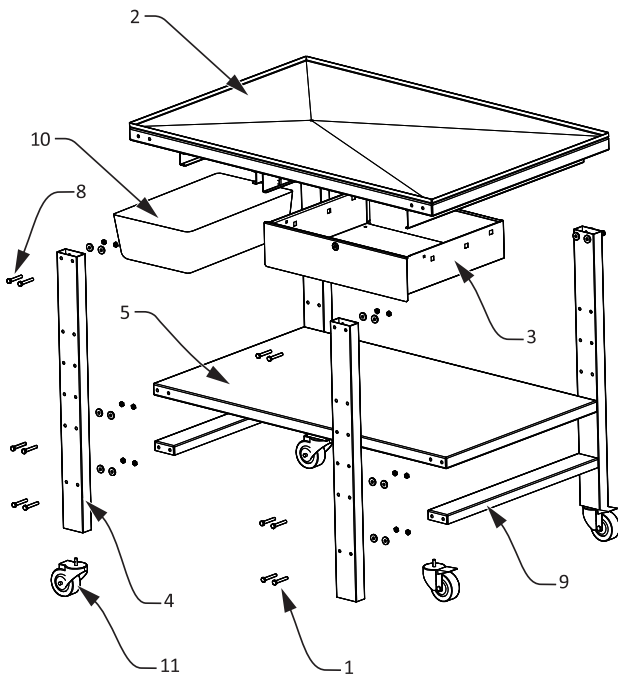

Callout	Illustration	Count	Description
1	M8 x 55	16 Pcs	Bolt with washer and nut
2		1 Pc	Workbench top
3		1 Pc	Drawer
4		4 Pcs	Leg
5		1 Pc	Shelf
6			
7			
8	M8 x 75	8 Pcs	Bolt with washer and nut
9		1 Pc	Beam
10		1 Pc	Oil receiver tray
11		4 Pcs	Caster

Assembly

1. Place workbench top (#2) upside down on a smooth surface
2. Attach the four legs (#4) to workbench top (#2) by bolts with washers (#1), then finger tighten
3. Attach the shelf (#5) to the legs (#4) by bolts with washers (#1), then finger tighten

NOTICE

If your Heavy Duty Workbench is a RWB-1TD – One Drawer, Fluid Catch model, please complete the assembly of your Heavy Duty Workbench using the 3a step listed below; if yours is not this model, please skip this step.

- 3a. Insert casters (#11) to all four legs.

4. Set the workbench upright, check that worktop is level, then tighten all the hardware with a wrench.

NOTICE

If your Heavy Duty Workbench is a RWB-2D – Two Drawer model, please complete the assembly of your Heavy Duty Workbench using the two steps listed below.

5. If the drawers are not installed, push on the black plastic levers on the sides of the drawer. Left side of drawer lever pressed up. Slide into drawer slot on (#1) workbench top.
6. Check if the keys work properly. Each drawer has its own two keys. If you require further assistance, please contact BendPak Ranger Service for information (please have the model and serial number of your unit available) at **(805) 933-9970** follow the prompts to reach the Service Department.

NOTICE

If your Heavy Duty Workbench is a RWB-1TD– One Drawer, One Fluid Catch model, please complete the assembly of your Heavy Duty Workbench using the last step listed below.

7. Install Plastic Oil Receiver Tray (#10) on the left side of (#2) workbench top.

Ranger[®]

30440 Agoura Road
Agoura Hills, CA 91301 USA
[bendpak.com](https://www.bendpak.com)